



CoRe+ MAX™

The fastest¹ Level 2 charging station

Designed to evolve as more drivers make the switch to electric vehicles, the CoRe+ MAX is destined to become an integral part of your fleet, commercial, or workplace application.

Easy to use and reliable

- Cable management system (CMS) with unique counterweight system for smooth retraction.
- Built to last with rugged Type 3R aluminum water resistant enclosure and integrated cable holster for neat, safe cable storage.

Versatile and efficient

- Save on electricity costs with patented PowerSharing™ and PowerLimiting™ technologies.
- Customizable installation choices suit a variety of parking configurations.

Smart Station, Smarter Investment

- Monitor station health and gain key insights with the cloud-based management dashboard.
- Maximize uptime with proactive station monitoring and remote intervention services.



For Workplace

Offer EV charging services to your employees, with a solution that will evolve with you as more drivers make the switch to electric vehicles.

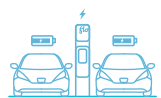

For Fleets

Ideal for fleet managers who wish to grow their light and medium duty EV fleets while maintaining affordable operational costs.

¹ As permitted under the SAE J1772 standard.

Available Configurations

DIMENSIONS

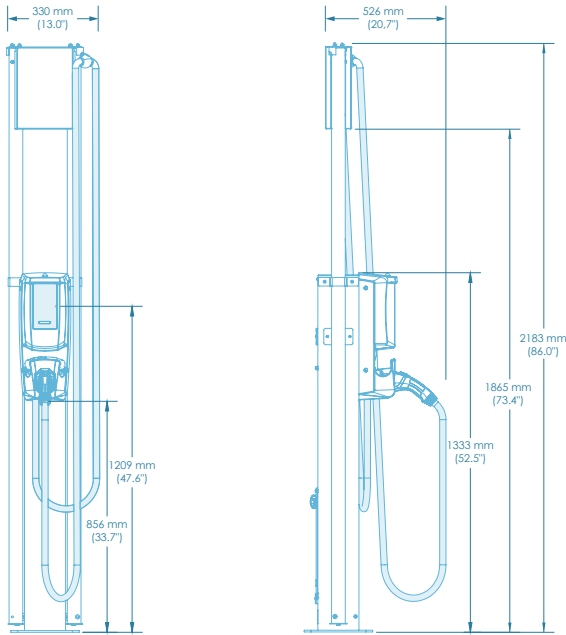

Single CoRe+ MAX on pedestal with CMS

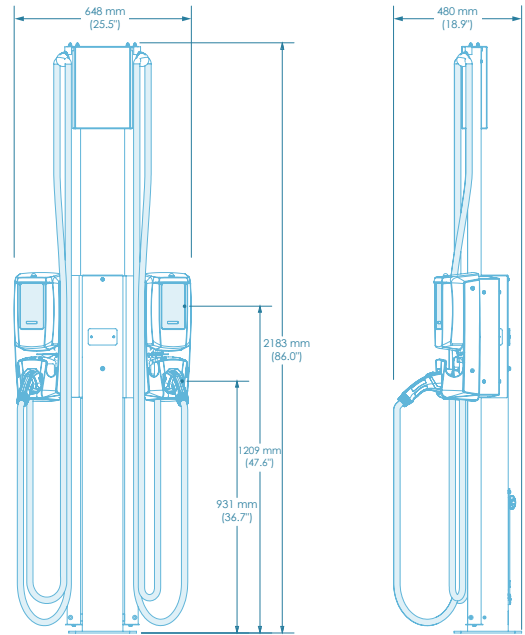

Dual side-by-side CoRe+ MAX on pedestal with CMS

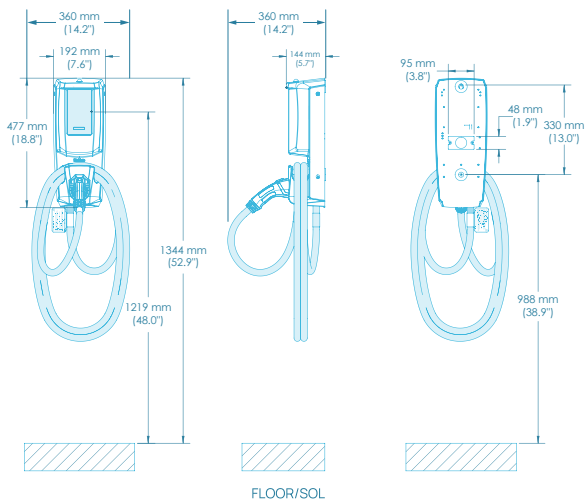

Wall Mount CoRe+ MAX (without CMS)

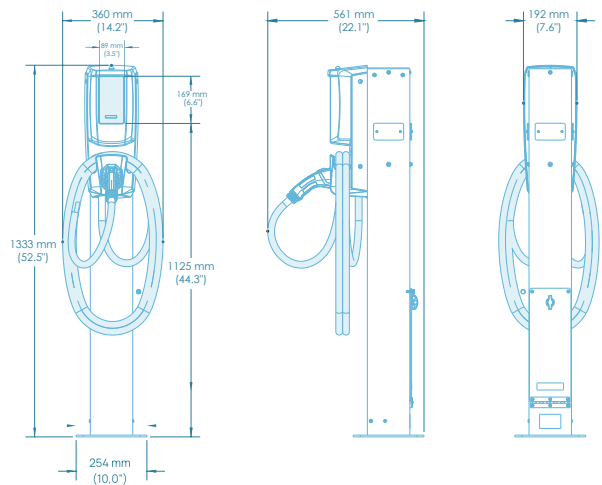

Single CoRe+ MAX on pedestal (without CMS)

Technical Specifications

HARDWARE

Enclosure	Aluminium Type 3R
Charging connector	SAE J1772
Cable length	7.62 m / 25 ft (without CMS)
Cable Management System (optional)	6.79 m / 19 ft cable - Calibrated suspended weight
Operating and storage temperature	40 °C to 50 °C / -40 °F to 122 °F
Weight	Charging station: 12.1 kg / 27 lbs; Pedestal: 14.5 kg / 32 lbs; CMS (CoRe+ MAX): 10.9 kg / 24 lbs
Humidity	Up to 95% (non-condensing)

ELECTRICAL

Electrical load	208 VAC or 240 VAC for each charging station
Charging power	1.2 kW to 19.2 kW (maximum configurable by software)
Output current	6 A to 80 A (maximum configurable by software and adjustable via a rotary switch)
Integrated GFCI	20 mA, auto reset (3 attempts at 15-minute intervals)
Frequency	60 Hz

INTERFACE

Card reader	ISO 14443 A/B, ISO 15693
-------------	--------------------------

CONNECTIVITY

Communication interface	ZigBee - IEEE 802.15.4 meshed network
Networking	Cellular - 4G/LTE (gateway is installed separately)

CERTIFICATION AND COMPLIANCE

Certifications	CSA- C22.2 No. 280 UL 2594, CSA C22.2 No 281.1 and 281.2 UL 2231-1 and 2231-2 UL Listed
EMI Compliance	USA - FCC 47 CFR part 15 class A CAN - ICES-003 (A)
Americans with Disabilities	ADA Compliant



Learn more
info@flo.com
1 (855) 543-8356
flo.com



Made in North America

Designed and manufactured by AddÉnergie
Technologies Inc. d/b/a FLO.



SmartDC™

Multi-Standard DC Fast Charging Station

The SmartDC™ is a robust, reliable, 50 kW or 100 kW multi-standard charging station for commercial and industrial applications designed for indoor and outdoor use. Its sturdy construction ensures longer service life and greater operational reliability, even in harsh environmental conditions.

Equipped with both CHAdeMO and SAE Combo (CCS1) connectors, the SmartDC charging station is designed to offer a fast, reliable charging experience for every electric vehicle capable of DC fast-charging.

The SmartDC comes with a remote management tool that connects with FLO's cloud-based servers, allowing for remote updates and monitoring. With this powerful capability, the SmartDC can be integrated into any modern EV Charging Network.

*The 50 kW SmartDC charger is shown here with the optional credit card reader and cable management system.



Key features

- Robust type 3R casing, reliable and designed to withstand harsh weather and corrosion
- Modular design to facilitate servicing and maintenance
- Available in two versions: 50 kW and 100 kW maximum output
- Compatible with the CHAdeMO and SAE Combo (CCS1) protocols (Tesla compatible, with adapter)
- RFID card and/or mobile app authentication and payment
- Optional cable management system in the 50 kW version
- Flexible billing based on time and/or kWh delivered, when permitted by local jurisdictions

Benefits

- Reduced Mean Time To Repair (MTTR) and enhanced customer experience with the remote management tool
- Interoperability with networks supporting OCPP1.6J
- Enhanced charging station owner experience with complete remote management capabilities including software and firmware update
- Enhanced user experience with real-time updates and notifications to drivers
- Revenue generation through payments via RFID member cards and mobile app
- Configurable Access Control
- Reduced lead time thanks to its North American manufacturing

Applications

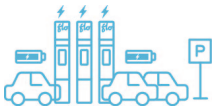

Commercial

For parking lot owners interested in offering their customers a first-class experience by providing EV DC fast-charging services.

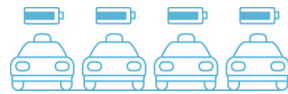

Fleet

For EV fleet managers who want to minimize charging time and maximize the usage rate of their fleet.

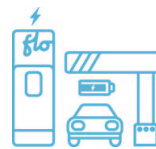

Gas stations

For gas station owners who wish to offer a complementary service that will help retain customers migrating to EVs.



Rest areas

For public administrators responsible for highways that wish to encourage electromobility between cities.

Dimensions and customization

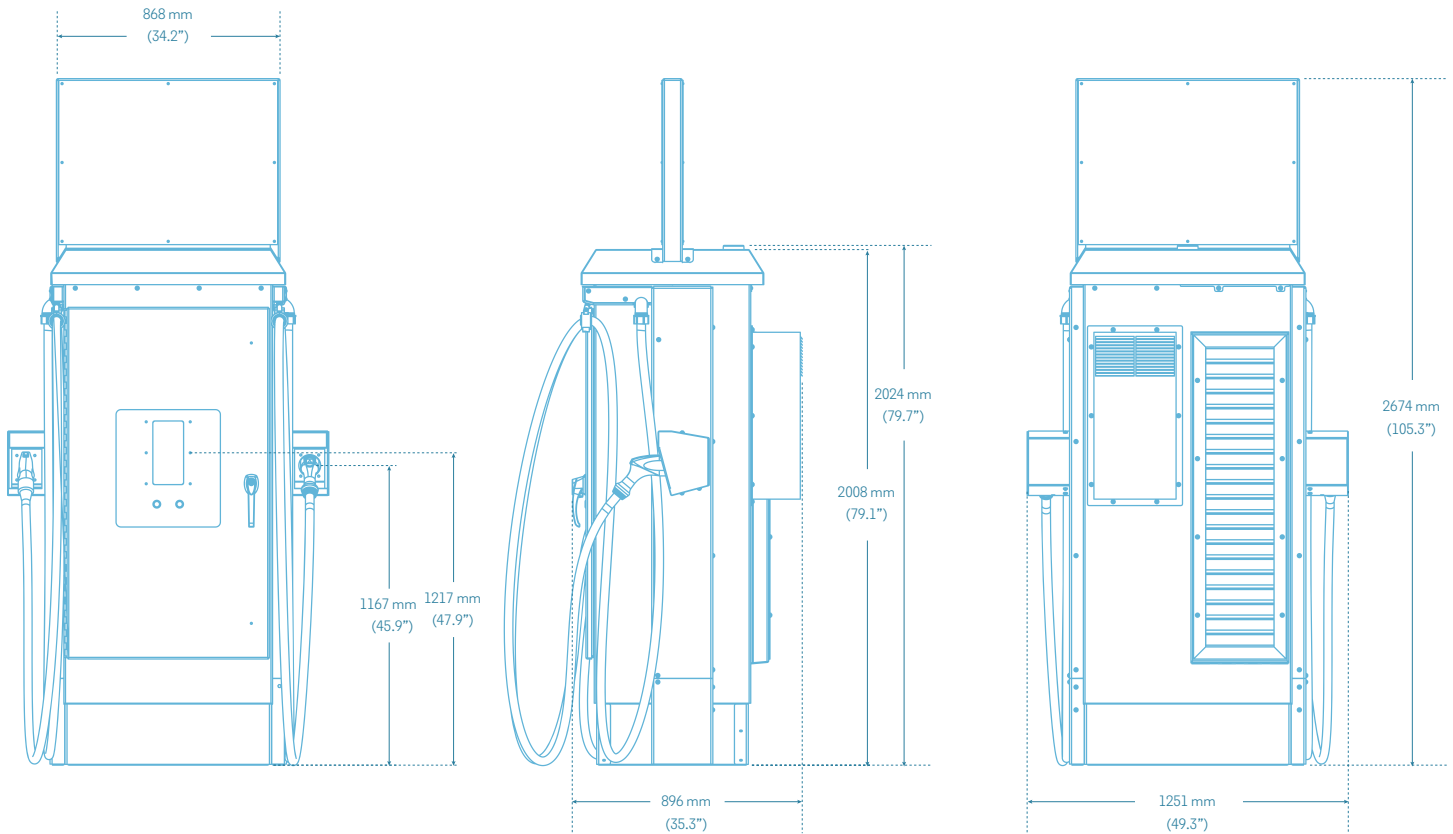

Every charging station includes a customizable branding area. This area allows the display of partner logos or other publicity.

Customizable partner panel area
 Dimensions (H x W): 25.5 cm x 40.64 cm (10.31" x 16.14")

Contact FLO™ for artwork templates and material specifications.

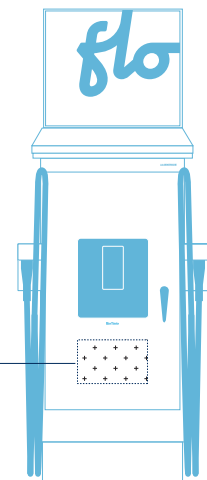

Technical specifications

	50 kW	100 kW
Casing	Aluminum Type 3R enclosure – Resistant to harsh weather and vandalism	
Charging connectors	SAE Combo (CCS1) and CHAdeMO	
Cable length	6.1 m (20') CMS included as an option	3.7 m (12')
Supply voltage	Nominal three-phase 480 Y/277 VAC (neutral required), 60 Hz nominal (408 to 528 VAC, 55 to 65 Hz)	
Maximum input current	65 A @ 480 VAC	130 A @ 480 VAC
Maximum input power	54 kVA	108 kVA
Power factor	98% or better	
Efficiency (at max. output power)	93% or better	
Output power measurement tolerance	+/-1%	
Output voltage range	50 to 500 VDC	
Output current range	0.5 to 125 ADC	0.5 to 200 ADC
Dimensions (H x W x D)	2,024 mm x 1,251 mm x 833 mm (79.7" x 49.25" x 32.8") Height with top sign installed 2,674 mm (105.28")	
Weight	255 kg (560 lbs) With cable management system 675 lbs (300 kg)	300 kg (675 lbs)
Operating temperature	-40 °C to 50 °C (-40 °F to 122 °F)	
Storage temperature	-40°C to +70°C (-40°F to 158°F)	
Humidity	Up to 95% (non-condensing)	
Credit card reader	Payment by credit card (tap, insert, swipe) and NFC (Google Pay, Apple Pay)	
RFID card reader	Fitted standard. Supports ISO 14443 A/B, ISO 15693.	
Certifications	cULus: UL 2202, UL 2231-1, UL 2231-2, CSA C22.2 No. 107.1 CSA C22.2 No. 281.1, CSA C22.2 No. 281.2 FCC part 15 Class A ICES-3 (A) Energy Star certified (*50 kW certified, 100 kW in progress)	
Networking	Cellular – 4G (LTE), HSPA+	
Model #	DCCH501AN1-FL-P03	DCCH501AO1-FL-P03



Designed and manufactured by
AddEnergie Technologies Inc.

For more information
info@flo.com
1 855 543 8356
flo.com

CoRe+ MAX™

Installation Guide



Table of Contents

1. About CoRe+ MAX	3
1.1. Canada and USA Electromagnetic Interference Regulatory Statement	3
1.2. Important Safety Instructions	4
1.2.1. Safety Symbols on your Unit	4
1.2.2. Instructions Pertaining to the Risk of Fire or Electric Shock	5
1.2.3. Important General Safety Instructions	5
1.3. Site Preparation Considerations Prior to Installation	7
1.3.1. Rotary Position Table	8
2. Communication Gateway	8
3. Installation Instructions	9
3.1. Dimensions and Nominal Installation Location	9
3.2. Power Cable Installation Under the Station	10
3.3. Power Cable Installation from the Back	11
3.3.1. Power Cable Entry on a Station with an Electrical Box or CoRe+ MAX Pedestal	12
3.3.2. Setting the Current Limit	13
3.4. Closing the Station Housing	15
3.5. Preliminary Tests and Commissioning	18
3.5.1. Station Status Light Indicator	19
4. Power Sharing	20
5. Operating Instructions	22
6. User Maintenance Instructions	23
7. Moving and Storage Instructions	23
8. Specifications	24
9. Copyright and Liability Information	25

1. About CoRe+ MAX

The CoRe+ MAX™ is part of a family of Level 2 charging stations that are suitable for a wide range of parking layouts, including workplaces, condos, apartments, fleets, and commercial properties. They are ideal for sites where several high-capacity electric vehicles such as commercial service trucks and school buses need to charge simultaneously because the chargers can be cascaded to minimize installation costs for the entire site.

1.1. Canada and USA Electromagnetic Interference Regulatory Statement

This equipment has been tested and found to comply with the limits for a Class A digital device, pursuant to part 15 of the FCC Rules. These limits are designed to provide reasonable protection against harmful interference when the equipment is operated in a commercial environment. This equipment generates, uses, and can radiate radio frequency energy, and if it is not installed and used in accordance with the instruction manual, it may cause harmful interference to radio communications. Operating this equipment in a residential area is likely to cause harmful interference, in which case the user will be required to correct the interference at their own expense.

This device contains license-exempt transmitters and receivers that comply with Innovation, Science and Economic Development Canada's license-exempt Radio Standards Specifications (RSSs). Operation is subject to the following two conditions:

1. This device may not cause interference.
2. This device must accept any interference, including interference that may cause unwanted operation of the device.

Changes or modifications to this equipment that have not been expressly approved by FLO may void the user's authority to operate this equipment.

Exposure to radio frequency energy: The radiated power output of the communication modules included in this device is below the limits recommended for the general population for uncontrolled exposure as defined in the FCC standards. This device should be operated with a minimum distance of at least 20 cm (7.87") between itself and

a person's body, and it must not be co-located or operated with any other antenna in order to comply with the conditions of the FCC grants.

1.2. Important Safety Instructions

Read all the instructions before using this product.

PLEASE SAVE ALL THE INSTRUCTIONS OF THIS MANUAL.

1.2.1. Safety Symbols on your Unit



Alternating current



Phase



Protective conductor (ground) connecting points

1.2.2. Instructions Pertaining to the Risk of Fire or Electric Shock



This symbol is used to warn you about hazardous voltage and the possibility of electric shock.

When using electrical products, basic precautions should always be followed, including the following. This manual contains important instructions for the CoRe+ MAX model that must be followed during the installation, operation, and maintenance of the unit.



This symbol is used to make you aware of important safety information in these instructions.

1.2.3. Important General Safety Instructions

Always follow the safety instructions below when installing or using the electric vehicle chargers:

- Children should be supervised around the device while it is in use.
- Never insert your finger into the electric vehicle connection.
- Never use the Electric Vehicle Supply Equipment (EVSE) if the flexible power cord or Electric Vehicle (EV) cable is frayed, has broken insulation, or shows any other signs of damage.
- Never use the EVSE if the EV connector enclosure is broken, cracked, open, or shows any other signs of damage.
- This EVSE was designed to be used with electric vehicles equipped with an SAE-J1772 connector.
- This EVSE must only be used to charge vehicles that do not require a ventilated environment during charging.
- Make sure to always disconnect the power supply of the EVSE before servicing it.
- Avoid installing the EVSE in bad weather conditions.

**CAUTION**

Always use a manual screwdriver. **DO NOT** use an impact driver for the screws at any time. This will void the warranty.

**CAUTION**

To reduce the risk of fire, only connect to a circuit equipped with appropriate branch circuit overcurrent protection (see the *Rotary Position Table* in *section 1.3.1.*) in accordance with the *Canadian Electrical Code (CSA C22.1-12)* and the *National Electrical Code (ANSI/NFPA 70)*.

1. Handle packaging with care. Always use safety glasses and gloves when unpacking and installing the device.
2. Contact a certified contractor, a certified electrician, or a trained installer to ensure compliance with local building codes, regulations, security standards, and weather conditions.
3. Verify with local authorities that the location where the EVSE is to be installed is free from underground pipelines or electrical equipment; otherwise, you might inflict serious injuries on yourself and others.
4. This EVSE is designed to be wall-mounted or pedestal-mounted.
5. If installed on a wall mount configuration, do not install on or over a combustible surface.
6. Ensure that the types of mounting surfaces of the wall and the posts are strong enough to support more than 56.7 kg (125 lbs.) per anchoring point in the vertical and horizontal direction.
7. Make sure that the anchors are compatible with the type of mounting surface.
8. This product must be connected to a grounded, metal, permanent wiring system. When this is not possible, an equipment grounding conductor must be run with the circuit conductors and connected to the equipment grounding terminal and installed by a certified electrician.
9. Altering any part of the EVSE will automatically void the warranty.

1.3. Site Preparation Considerations Prior to Installation



Avoid installing the Electric Vehicle Supply Equipment (EVSE) in bad weather conditions.

- Split Phase 120/240 VAC supply or single phase 120/208 VAC. Refer to *Figure 1* and *Figure 2* in the image below.
- Both lines must have 120 V between ground.
- The voltage supply must be grounded.
- The electrical wiring requires 2 lines and 1 ground connection. Neutral is not used. Refer to Figure 1 and Figure 2.
- Maximum output power: 19.2 kW @ 240 VAC or 16.6 kW @ 208 VAC.
- Built-in protection against overvoltage conditions and leakage current to ground.
- Use 90 °C (194 °F) copper wire conductors only.
- Field terminals accept wires between 3 AWG and 14 AWG.

Fig. 1

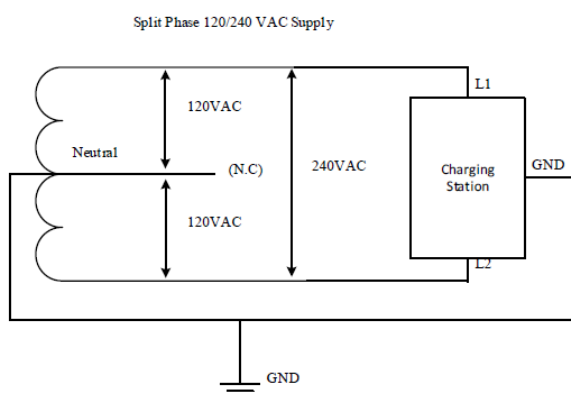
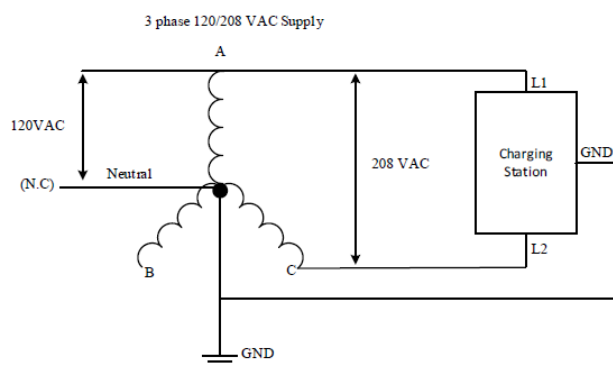

Fig. 2



1.3.1. Rotary Position Table

Rotary Position	Charging Station Current (A)	Recommended Circuit Protection (A)	Recommended Wire Gauge (AWG)
0	80	100	3
1	72	90	3
2	64	80	4
3	59	80	4
4	56	70	4
5	48	60	6
6	40	50	6
7	32	40	8
8	24	30	10
9	16	20	14

2. Communication Gateway

Install the Communication Gateway prior to the commissioning of the station. The communication gateway is the property of FLO. Fees will be charged if the gateway is damaged, lost, or not installed according to the installation guide.

Outdoor installation is recommended. The Customer must provide a waterproof PVC box and install it less than 48.7 m (160') from the stations.

Refer to the *Communication Gateway Installation Guide* for more information. Contact us once the communication gateway has been installed to validate the signal levels and activate commissioning or for any other questions: 1 855 543 8356.

3. Installation Instructions

The CoRe+ MAX can be mounted on a wall or pedestal. Depending on the installation, the power cables can be connected in three different ways (see *sections 3.2 to 3.4*). If mounted on a CoRe+ MAX pedestal, please refer to the *CoRe+ MAX Pedestal Installation Guide* for the pedestal installation procedure prior to the CoRe+ MAX installation.

3.1. Dimensions and Nominal Installation Location

Back side: 2 matching holes and a rectangular cable opening when pedestal is mounted

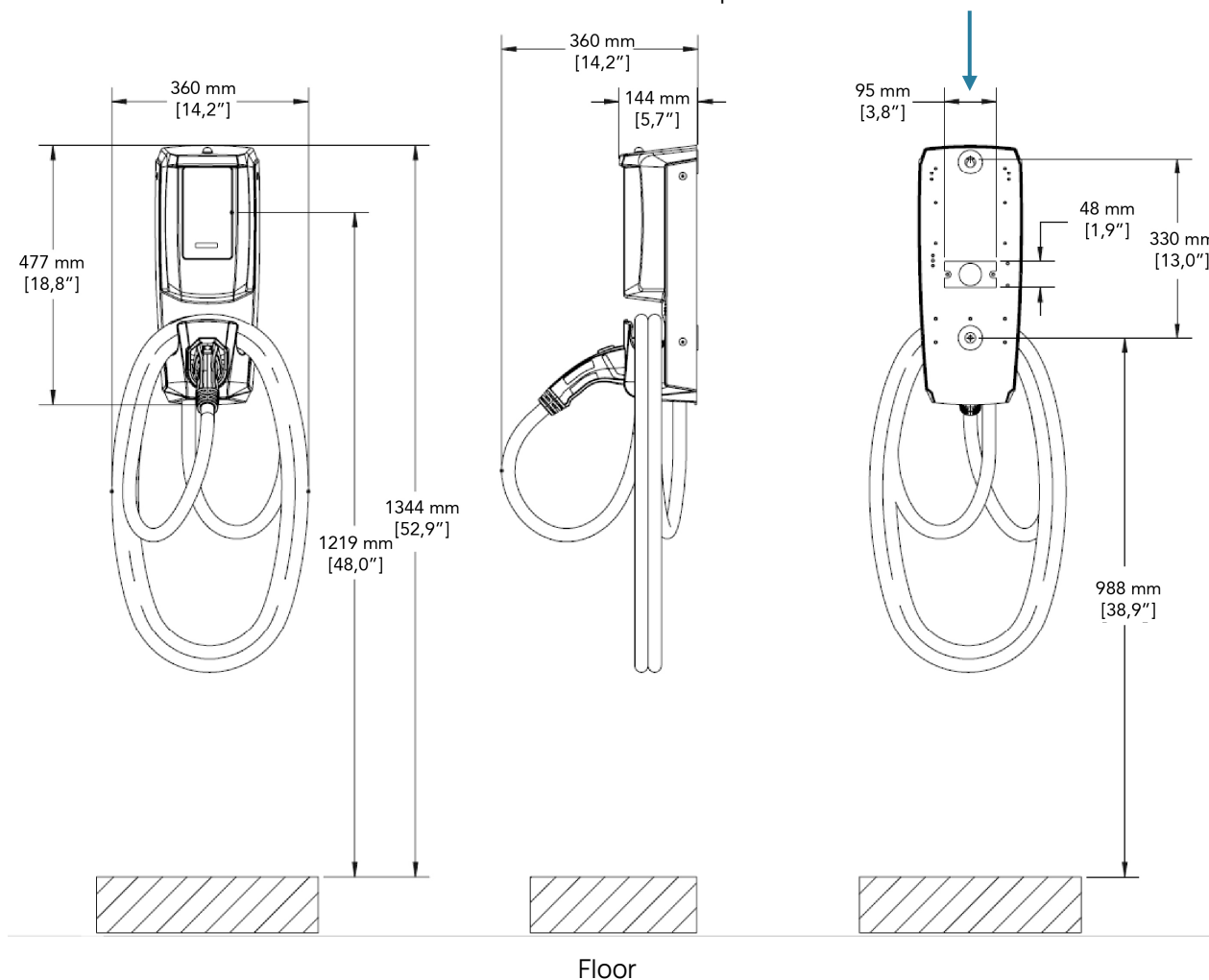

3.2. Power Cable Installation Under the Station

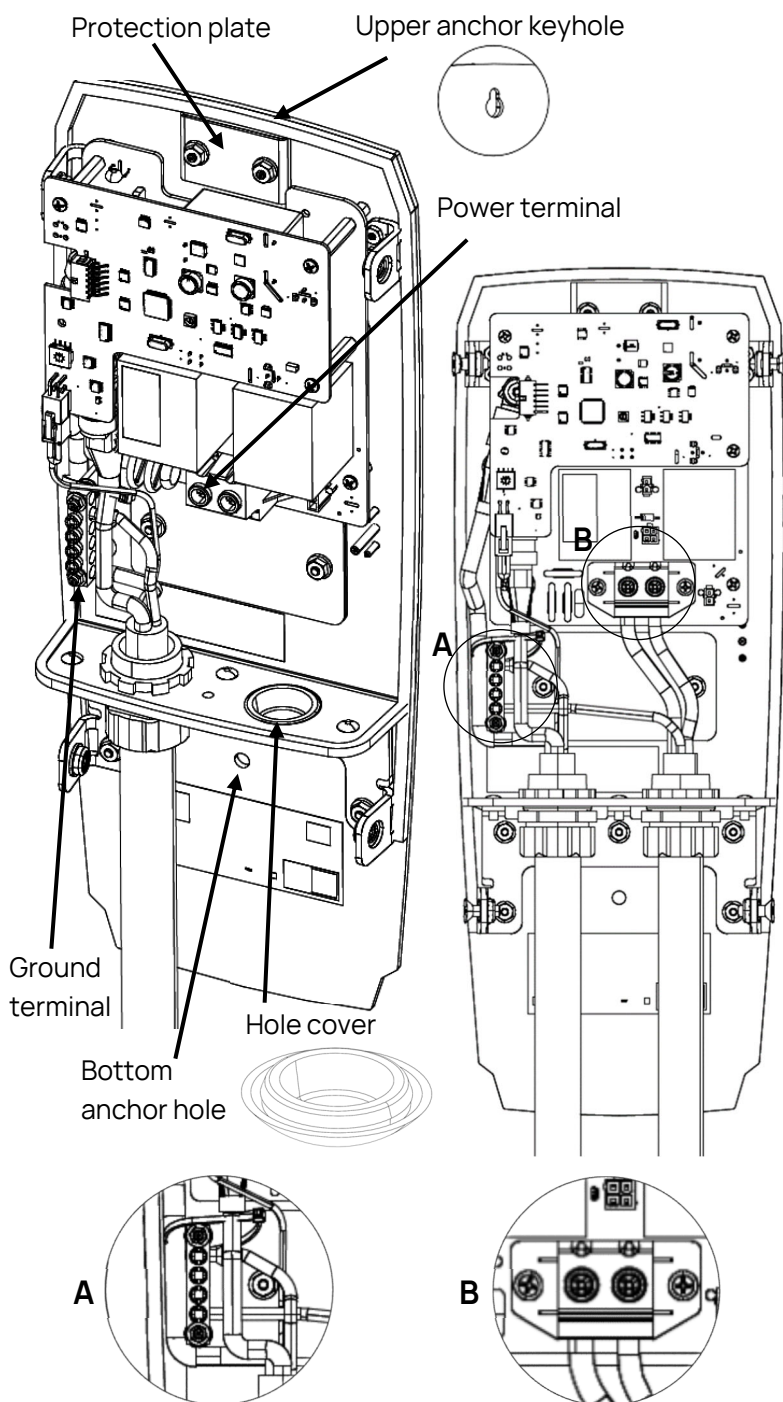

Avoid installing the EVSE in bad weather conditions.



IMPORTANT

The protection plate should always remain over the keyhole.

Follow the steps below to install the power cable under the station:

1. Attach the head base to the wall or post with an anchoring apparatus that can support at least 56.7 kg (125 lbs.) per anchor point (2) in the vertical and horizontal direction.

2. Hang the head base on the upper anchor (previously attached to the wall or post) via the upper anchor keyhole. While doing so, ensure that there is a tight fit and that there is no gap between the gasket and the mounting wall.

3. Complete the mounting of the head base by screwing a mounting bolt through the bottom anchor hole.

4. Remove the hole cover and attach the cable connector to the hole from the bottom, then insert the power cable. Ensure that the conductors are long enough to reach the terminal block. Make sure to seal the cable hole correctly. Ensure that the cable is attached properly by tightening the cable connector (not included).

Note that the hole is 3.5 cm (1.375").

5. Connect the two power conductors (L1 and L2) and the ground conductor (GND) as indicated with the appropriate torque.

6. The ground conductor must be connected to the terminal ground.

Ground conductor connection - GND

Torque

6 AWG	→ 4 N-m [35 lb-in]
8 AWG	→ 2.8 N-m [25 lb-in]
10 AWG	→ 2.3 N-m [20 lb-in]

Power conductor connection - L1L2

Torque

3 AWG	→ 3 N-m [27 lb-in]
4 to 14 AWG	→ 2.5 N-m [22 lb-in]

3.3. Power Cable Installation from the Back

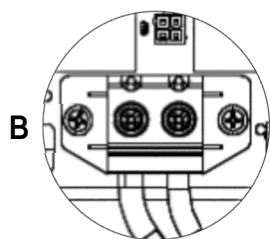
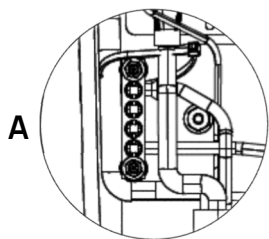
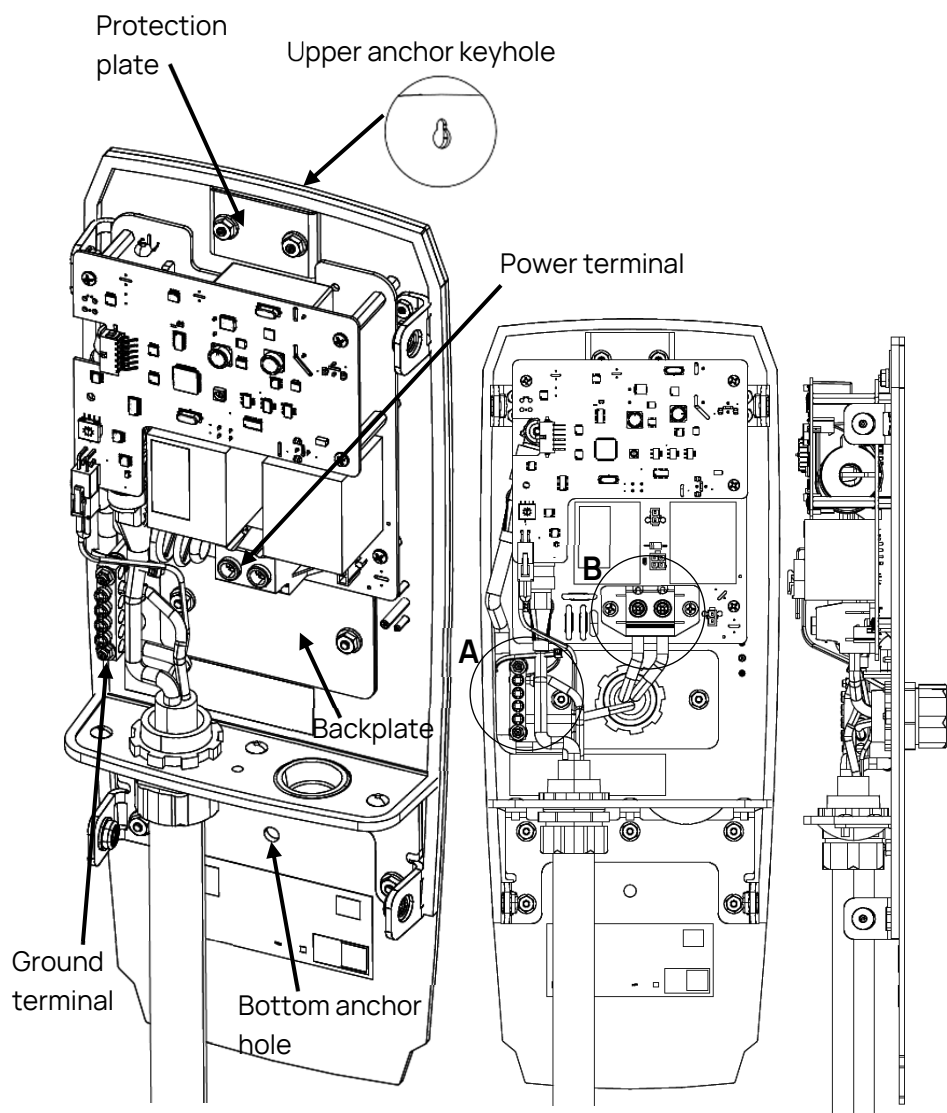

Ground conductor connection - GND		Power conductor connection - L1L2	
<u>Torque</u>		<u>Torque</u>	
6 AWG	→ 4 N-m [35 lb-in]	3 AWG	→ 3 N-m [27 lb-in]
8 AWG	→ 2.8 N-m [25 lb-in]	4 to 14 AWG	→ 2.5 N-m [22 lb-in]
10 AWG	→ 2.3 N-m [20 lb-in]		



Avoid installing the EVSE in bad weather conditions.



IMPORTANT:
The protection plate should always remain over the keyhole.

1. Attach the head base to the wall or post with an anchoring apparatus that can support at least 56.7 kg (125 lbs.) per anchor point (2) in the vertical and horizontal direction.

2. Hang the head base on the upper anchor (previously attached to the wall or post) via the keyhole at the top. While doing so, ensure that there is a tight fit and that there is no gap between the gasket and the mounting wall.

3. Complete the mounting of the head base by screwing a mounting bolt through the bottom anchor hole.

4. Remove the back plate to prevent particle splatter on the equipment.

5. Punch a hole of the appropriate diameter in the back plate to install the cable connector. **Note** that the pre-punched hole diameter on the back plate is 34.5 mm (1.36").

6. Put the back plate back in its place.

7. Install the cable connector in the hole punched into the back plate, then install the cable. Ensure that the conductors are long enough to reach the terminal block. Make sure that the hole is sealed properly.

8. Connect the two power conductors (L1 and L2) and the ground conductor (GND) as indicated with the appropriate torque.

9. The ground conductor must be connected to the terminal ground.

3.3.1. Power Cable Entry on a Station with an Electrical Box or CoRe+ MAX Pedestal

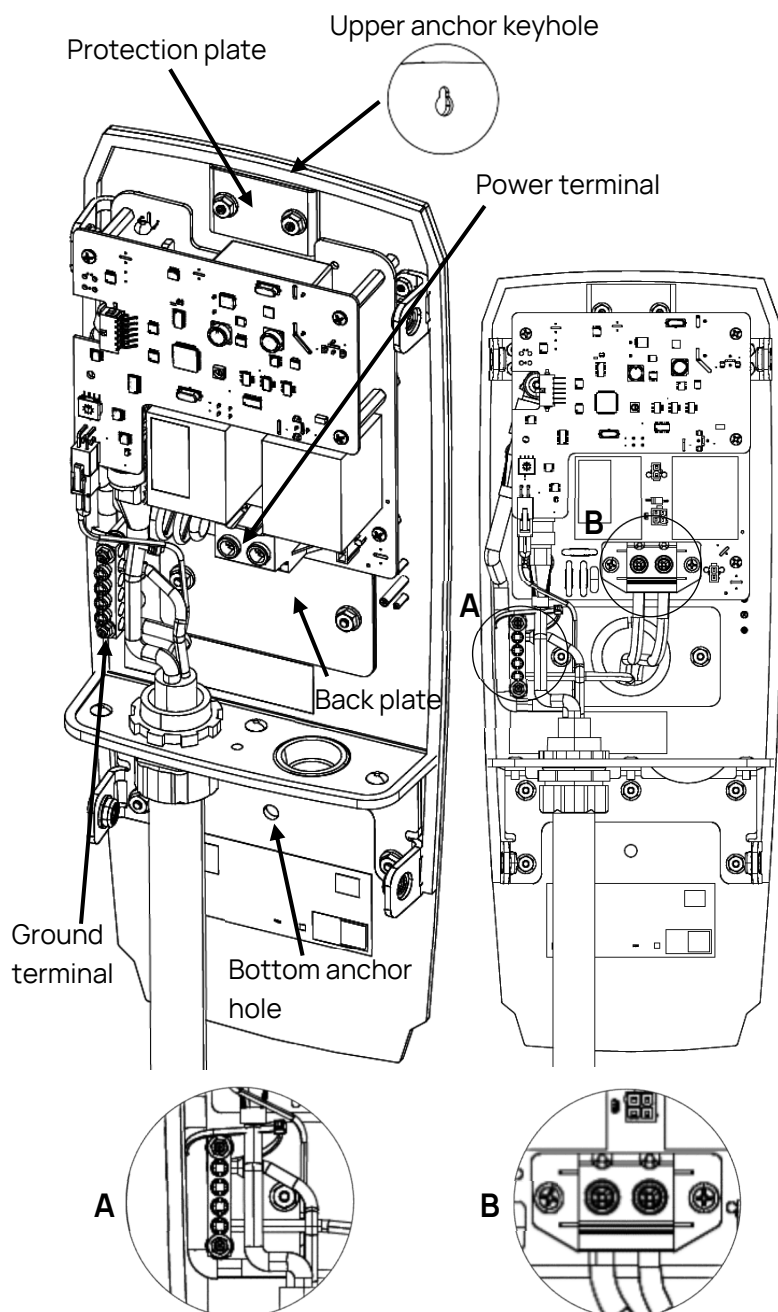

Avoid installing the EVSE in bad weather conditions.



IMPORTANT:
The protection plate should always remain over the keyhole.

1. Remove the back plate.
2. Install the head base to align the rectangular opening with the box opening in the wall or post.
3. Attach the head base to the wall or post with an anchoring apparatus that can support at least 56.7 kg (125 lbs.) per anchor point (2) in the vertical and horizontal directions.
4. Hang the head base on the upper anchor (previously attached to the wall or post) via the keyhole at the top. While doing so, ensure that there is a tight fit and that there is no gap between the gasket and the mounting wall.
5. Complete the mounting of the head base by screwing a mounting bolt through the bottom anchor hole.
6. Make sure that the opening between the charging station and the electrical box or pedestal is properly sealed.
7. Connect the two power conductors (L1 and L2) and the ground conductor (GND) as indicated with the appropriate torque.
8. The ground conductor must be connected to the terminal ground.

Ground conductor connection - GND	Power conductor connection - L1L2
<p><u>Torque</u></p> <p>6 AWG → 4 N-m [35 lb-in]</p> <p>8 AWG → 2.8 N-m [25 lb-in]</p> <p>10 AWG → 2.3 N-m [20 lb-in]</p>	<p><u>Torque</u></p> <p>3 AWG → 3 N-m [27 lb-in]</p> <p>4 to 14 AWG → 2.5 N-m [22 lb-in]</p>

3.3.2. Setting the Current Limit

By default, the CoRe+ MAX is set to maximum power in the factory. If your electrical infrastructure does not allow the charging station to operate at maximum power, it can be reduced using the **Current Limiter Switch**.



WARNING

Make sure that the power is off.

Follow the steps below to set the current on the charging station:

1. Locate the **Current Limiter Switch** on the main Printed Circuit (PC) board.

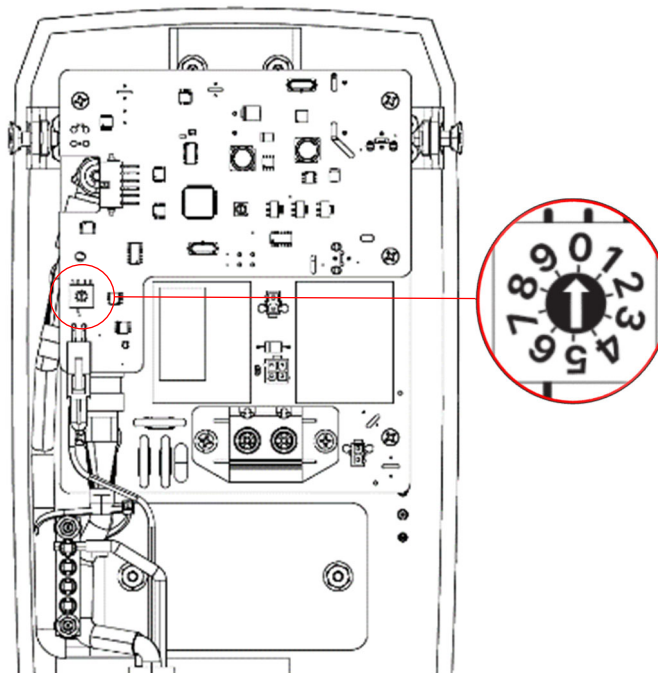

- Using a flat-head screwdriver, gently rotate the switch to the desired position. Refer to the following table to determine the rotary position:

Rotary Position	Charging Station Current (A)
0	80
1	72
2	64
3	59
4	56
5	48
6	40
7	32
8	24
9	16

- Detach the corresponding maximum current setting label sticker from the label set kit that comes with the unit. Stick it over the existing label on the charging station enclosure to inform the maintenance personnel of the maximum current setting. Proof of installation will be required to complete the commissioning to ensure that the label corresponds to the installation. This is important for safety and warranty validity considerations.



E509366

This device complies with part 15 of the FCC Rules. Operation is subject to the following two conditions:
 (1) This device may not cause harmful interference, and
 (2) This device must accept any interference received, including interference that may cause undesired operation.

FCC compliance contact: FLO Services USA Inc.
 75 South Clinton Ave., Suite 510, Rochester, NY 14604

Contains: FCC ID: MCQ-PROS2C & JQ6-SE3210
 IC ID: 1846A-PROS2C & 2236B-SE3210.
 CAN ICES-3 (B) / NMB-3 (B)



Modèle / Model : CoRe+ MAX AddÉnergie Technologie. Inc.

Mfg. Date : AAAAMM

Operating temp. / Temp. d'utilisation: - 40 °C to/à 50 °C (- 40 °F to/à 122 °F)

⚠ Input-Output Voltage / Alimentation: 208 or 240V ~ ,60 Hz - 1 ⚡

Brevet/Patent: www.addenergie.com/patents

Current/
 Courant : **80 A**

Current sticker

3.4. Closing the Station Housing

1. Ensure that the gasket on the lip shown below is properly aligned.

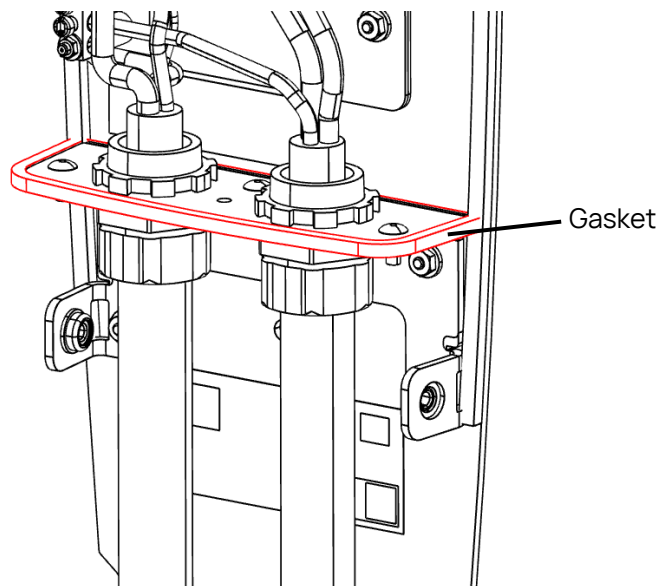

2. Connect the data cable to its respective connector as shown below.

WARNING: NEVER CONNECT/DISCONNECT THE DATA CABLE WHEN THE CHARGING STATION IS ENERGIZED. THIS COULD DAMAGE THE UNIT.

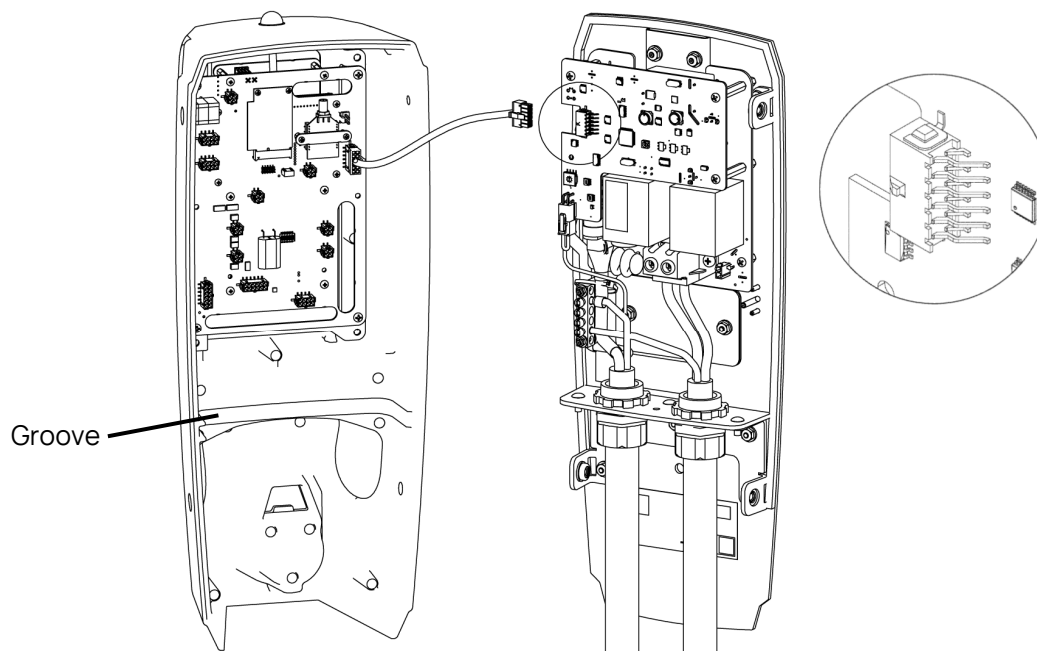

- Align the housing groove to the charging station lip and push the housing toward the charging station, ensuring that the gasket stays in place.

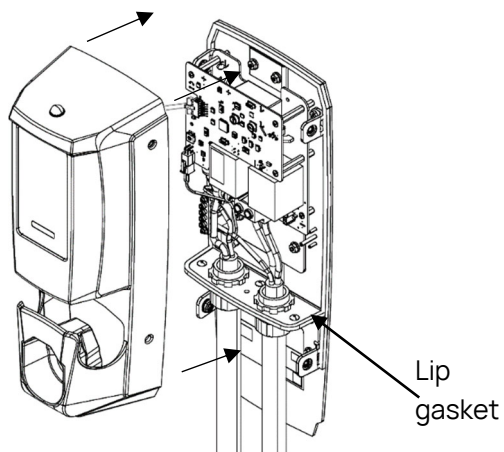

- Apply slight pressure to the front cover, then screw on the top 2 bolts, ensuring that the O-rings stay on the screws. Screw on the bottom 2 bolts. Tighten all screws to 30 lb-in (3.4 N-m).

WARNING: NEVER USE AN IMPACT DRIVER TO AVOID DAMAGING THE THREADS!

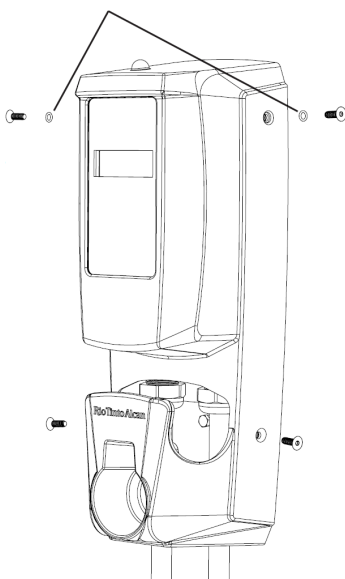

5. Place the charging cable on the cable holder and the charging connector in the receptacle.

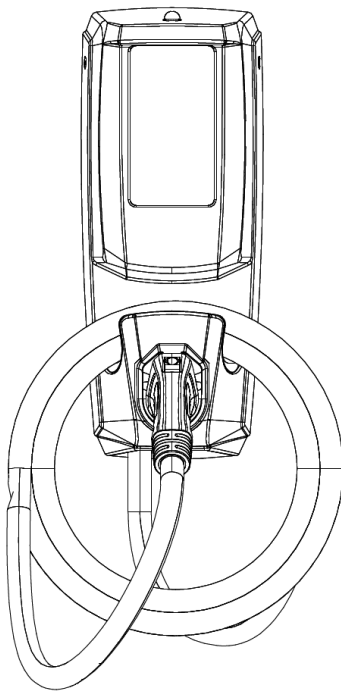

3.5. Preliminary Tests and Commissioning



Follow the steps below to complete the preliminary tests and commissioning:

1. Turn on the power to the charging station. You should be able to observe the following results immediately after the power is turned on:

- a. The status light is on continuously; its color is green.
- b. The greeting message is displayed.





NOTE: If no message appears, ensure that the data cable is connected by following step 2 in *section 3.4. 3.4.* while the station is NOT energized.

2. Scan the access card provided with the charging head. You should be able to observe the following results:

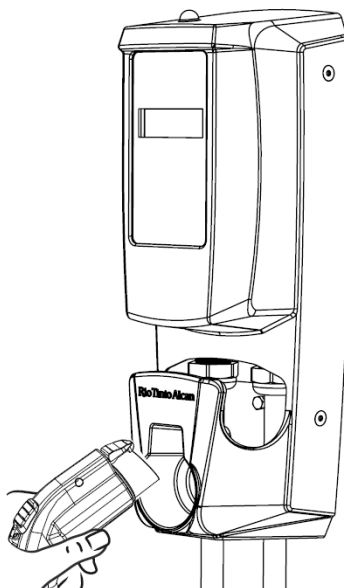
- a. Once the reader detects the card, it will emit an audible beep.
 - b. Immediately after the beep, the access card will be authenticated by the charging station.
 - c. If the authentication of the card is successful, the automated test of the protection circuit will be performed.
 - d. Once the test is successfully completed, the overhead status light will start flashing (white).
 - e. If the connector is inserted into an electrical vehicle, it will begin charging. If it does not begin charging after 1 minute, the charging station is in wait mode.
3. Once the charging station successfully passes the preliminary test, the charging station can be used as a private charging station (using the provided access cards) or be connected to FLO's management system by turning on the communication gateway provided by FLO. Call FLO Services at the number provided on the sticker in front of the charging station to process the commissioning step. If the commissioning is not completed, the station will be limited to 6 A when manufactured in power sharing mode.

3.5.1. Station Status Light Indicator



Color	Meaning
 Green - Solid color	The charging station is ready for session activation.
 White - Blinking	Session authenticated; the charging station is ready to plug into the electric vehicle (EV).
 Blue - Solid color	The charging station is plugged in, and energy is being delivered.
 Red - Solid color	Critical fault
 Off	Out of service

4. Power Sharing

The CoRe+ MAX can be configured in standard or power sharing mode. With the integrated power sharing capability of the CoRe+ MAX, a maximum of four charging stations sharing the same 100 A circuit for a total load of 80 A can be connected in parallel to the same branch circuit. Here are some characteristics of power sharing mode:

- The charging stations connected in parallel to the same branch circuit must all be CoRe+ MAX models (the specific model identification can be found on the unit label).
- To allow for dynamic current sharing, a site controller application must be installed and properly configured by FLO.
- Without a site controller installed or in operation, or in the event of a loss of communication, each CoRe+ MAX limits its output to 6 A when set in power sharing mode.
- The site controller will then ensure that the maximum available current is shared optimally among the charging stations (between 6 A and 80 A for each station) while ensuring that the maximum circuit capacity (80 A in the case of a circuit protected by a 100 A breaker) is never exceeded.
- For safety reasons, each CoRe+ MAX charging station will immediately interrupt an ongoing charging session when the connected EV draws more than the specified amperage limit at any time. To resume charging, the user must restart the usage session process from the beginning.
- The site controller is provided by FLO as part of its Global Management Service (GMS).
- The communication between the site controller and the charging station is done through a wireless meshed Zigbee network. A communication gateway must therefore be installed. Refer to the Communication Gateway Installation Guide provided by FLO for further details.

The maximum number of charging stations sharing the same 100 A circuit (for a total load of 80 A) is 4.

Typical Installation

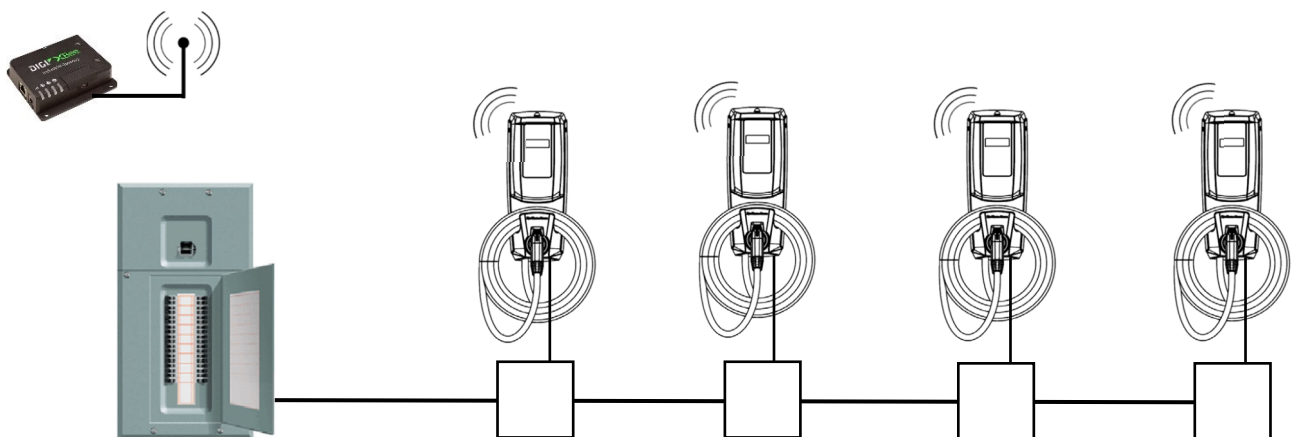

208 or 240 V @ 100 A circuit¹

Junction boxes allowing the charging stations to be connected in parallel to the same branch circuit

NOTE: Ensure that the electrical wiring and the associated electrical hardware used to connect the charging stations in parallel comply with the local regulations in place.

5. Operating Instructions

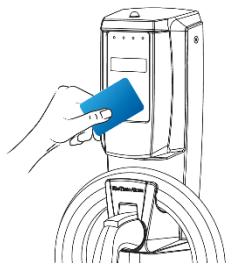

1. **Activate the station:**
Place your card on the reader OR select the station in the mobile app and press “Start a session.”

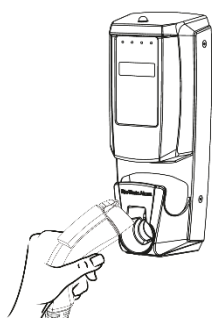

2. Pick up the connector and unwind the cable to the required length.

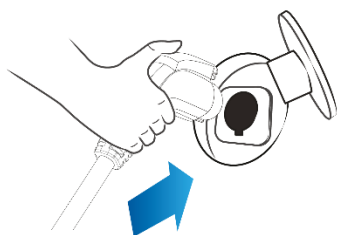

3. Plug the connector into your vehicle. The charging will start immediately.

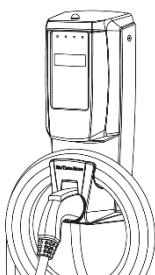

4. Once the charging is complete, put the connector back in its socket.

WARNING: Once the charging is complete, make sure to wind the cable back up and store the connector in its socket.

6. User Maintenance Instructions

The CoRe+ MAX enclosure is Type 3R, which is intended for indoor or outdoor use and provides a degree of protection against corrosion, windblown dust, rain, splashing water, and hose-directed water. It is designed to remain undamaged by ice, which can form on the enclosure.

This enclosure type ensures that the maintenance required to protect the integrity of the charging station enclosure is minimal, except for cleaning, which can be performed with standard domestic products recommended according to the type of dirt.

When not in use, the charging cable should be properly wound around the holder on the station enclosure, and the cable connector should be always inserted into its enclosure. **Do not** twist, bend, or pull on the cable from the connector alone, either to wind it around the enclosure or when it is stuck.

When handling the cable, please ensure that the cable's outer insulation and the connector itself do not show any excessive signs of wear, such as cracks or abrasion. If there is any damage, please call the Installation or Commissioning Questions number at the end of this manual for reporting and case management purposes.

7. Moving and Storage Instructions

The charging station is designed to remain in a fixed position and is not intended to be portable.

Prior to installation, we recommend that the station be kept in its shipping packaging at temperatures between -40 °C and 50 °C (-40 °F to 112 °F) and at a humidity level not exceeding 95% (non-condensing) until it has been installed by qualified personnel.

8. Specifications

Specification	Description
Description of the charger	Level 2, 80 A charging station equipped with display and card reader
Output connector	Output connector: J1772-compliant
Input connector	Split Phase 120/240 VAC supply or single phase 120/208 VAC (refer to Figure 1 and Figure 2)
Maximum output power	Maximum configurable output power: 19.2 kW @ 240V or 16.64 kW @ 208V
Operating temperature range	Operating temperature range: -40 °C to 50 °C (-40 °F to 122 °F)
Built-in protection	Overvoltage conditions and leakage current to ground
Enclosure	3R-type enclosure; suitable for outdoor use
Shipping weight	Approximately 12.15 kg (27 lbs.)
Communication protocols	OCPP version 1.6J
Security standard certification	EMI compliance: USA - FCC 47 CFR part 15 class A CAN - ICES-003 (A)
	CSA- C22.2 No. 280 / UL 2594, CSA C22.2 No. 281.1 and 281.2 / UL 2231-1 and 2231-2



9. Copyright and Liability Information

Name: FLO_CoRe+ MAX_Installation Guide_V.2.0.5_2023-02-07_CA_EN
ID: PRFM0042

FLO CA: © 2022 Services FLO Inc. All rights reserved. FLO, the FLO logo, LEAD THE WAY, and TRACEZ LA VOIE are trademarks of Services FLO Inc. ADDÉNERGIE is a trademark of AddÉnergie Technologies Inc. used under license by Services FLO Inc.

This document is provided as a general instruction guide. All pictures shown are for illustrative purposes only. Actual stations may vary in size or due to product enhancements, in which case additional steps may be required. AddÉnergie Technologies Inc. and its subsidiaries (“AddÉnergie”) reserve the right to alter this document and any product offerings and specifications at any time without notice, and AddÉnergie does not guarantee that this version of the document is current. It is your responsibility to comply with all applicable laws, including those related to accessibility and zoning, and to exercise due diligence when performing an installation or using this product. Careless installation or misuse may result in injury or product damage. To the fullest extent permitted by applicable laws, AddÉnergie disclaims any liability for personal injury or property damage resulting from the installation or use of this product.

Contact us

Telephone: 1 855 543 8356

Email: Info@flo.com

Website: Flo.com



Eastern office: 2800, Louis-Lumière Street, office 100, Québec, QC, Canada - G1P 0A4

Regional office - Western Canada: #501 - 4190 Lougheed Highway, Burnaby, BC, Canada
- V5C 6A8

United States office: 75 South Clinton Ave., suite 510, Rochester, NY, USA - 14604