

Terra 54 & 54HV

All-In-One 50kW DC Fast Charger



Description

Building on a decade of EV fast charging experience, the Terra 54 offers enhanced usability and reliability in an all-in-one package. The Terra 54 enables continuous 50 kW charging up to 500 VDC, and the Terra 54HV supports up to 920 VDC – accommodating the CCS functionality.

Key Benefits and Features

- 50 kW DC fast charger supporting CCS and CHAdeMO
- Paralleled power module topology with automatic failover offers high uptime through redundancy
- RFID authorization modes
- Robust all-weather powder-coated stainless steel enclosure

Specifications

- Available with CCS1 or CCS2 and Dual CCS1 or CCS2 connectors
- DIN70212 and ISO15118 protocols supported
- IP54, NEMA 3R; indoor and outdoor rated
- Dimensions (D x W x H): 30.7" x 22.2" x 74.8" / 780mm x 565mm x 1900mm
- Weight: 350 kg / 775 lbs



The Terra 54, shown with the CCS Configuration

Ordering Information

Configuration	SKU
Terra 54 CCS1/CHAdeMO w/CCR	ADC-50LV-480-C1CH-AC1RC
Terra 54HV Single CCS1	ADC-50HV-480-C1-AC1R
Terra 54HV Single CCS1 w/CCR	ADC-50HV-480-C1-AC1RC
Terra 54HV CCS1/CHAdeMO	ADC-50HV-480-C1CH-AC1R

Technical Specifications

Configuration	SKU
Voltage	480VAC +/- 10 %
AC Input Power Connection	3-phase: L1, L2, L3, GND
Frequency	60 Hz
Recommended breaker	80A
Power factor	>0.96
THD - Current	IEEE 519 Compliant; 5%
Output Parameters	Value
Voltage	200 - 500 VDC; 200 - 920 VDC (HV)
Current - Max	125 A
Power - Max	50kW
System Efficiency - Max	>95%
Controls and Interface	Value
Charging Connectors	CCS
HMI	7" TFT LCD Display
Communication	OCPP 1.6J
Network Connection	GSM/3G/4G modem; 10/100 Base-T Ethernet
RFID	ISO/IEC 14443A/B, ISO/IEC 15393, Mifare, Calypso
Language	English (others available on request)
Environment	Value
Temperature - Operating	-31 °F to +131 °F / -35 °C to +55 °C *
Temperature - Storage	14 °F to +158 °F / -10 °C to +70 °C
Humidity	5 - 95%
Altitude - Operating	Power derates 15% every 1 km above 2 km
Protection - Intrusion	IP54, NEMA 3R; indoor and outdoor rated
General	Value
Cable Length	19.6 ft (6 m)
Cable Length - Optional	25 ft (CCS1 only - contact InCharge)
Safety and EMI	UL 2202, NEC Article 625, EN 61851, EN 62196

* Derating characteristics apply at extreme temperatures





MANUAL

Terra 54 / 54HV charger Installation Manual (NAM version)





Notice

This document contains information about one or more ABB products and may include a description of or a reference to one or more standards that may be generally relevant to the ABB products. The presence of any such description of a standard or reference to a standard is not a representation that all of the ABB products referenced in this document support all of the features of the described or referenced standard. In order to determine the specific features supported by a particular ABB product, the reader should consult the product specifications for the particular ABB product.

ABB may have one or more patents or pending patent applications protecting the intellectual property in the ABB products described in this document.

The information in this document is subject to change without notice and should not be construed as a commitment by ABB. ABB assumes no responsibility for any errors that may appear in this document.

In no event shall ABB be liable for direct, indirect, special, incidental or consequential damages of any nature or kind arising from the use of this document, nor shall ABB be liable for incidental or consequential damages arising from use of any software or hardware described in this document.

This document and parts thereof must not be reproduced or copied without written permission from ABB, and the contents thereof must not be imparted to a third party nor used for any unauthorized purpose.

Copyrights

All rights to copyrights, registered trademarks, and trademarks reside with their respective owners.
Copyright © 2019 ABB.
All rights reserved.



Version Control

Version	Date	Author	Description
1.0	2019-02-15	R.T.-S., A.L.	Initial release of NAM version



Contents

Glossary	5
1 Introduction	6
1.1 Preface	6
1.2 Intended document users	6
1.3 Similarities and differences between Terra 24 and Terra 54.....	6
1.4 Terra version description	7
1.5 Signs.....	7
1.5.1 Owner responsibilities	8
1.5.2 Tilting and handling.....	8
1.5.3 Sharp edges.....	9
1.5.4 Electric hazards	9
1.5.5 Installation safety.....	9
1.6 Environment and disposal of waste	10
2 Description of the product.....	10
2.1 Overview of the system.....	10
2.1.1 Complete overview	10
2.1.2 Outside view.....	11
2.1.3 Inside view	11
2.2 Geometry of infrastructure	12
2.2.1 Required space for placing and maintaining the Terra 54.....	12
2.2.2 Ventilation and airflow of the Terra 54.....	13
2.2.3 Bollards.....	14
2.3 Electrical engineering	14
2.3.1 Requirements External RCD.....	15
2.3.2 Conductor and cable diameter	15
3 Site design.....	16
3.1 Cable reach	16
3.2 Different alignment possibilities.....	17
4 Site construction.....	18
4.1 About construction.....	18
4.2 Power feed.....	18
4.3 Construct foundation.....	18
4.4 Power cable	19
4.5 Internet connection	19
5 Receiving, Placing and connecting	20
5.1 Receiving the cabinet.....	20
5.2 Unpacking cabinet, mounting preparations.....	21
5.2.1 Unpacking.....	21
5.2.2 Mounting preparations.....	22
5.3 Move cabinet to position.....	23
5.3.1 Options.....	23



5.3.2	Move cabinet with hoist	24
5.3.3	Move cabinet forklift truck.....	25
5.4	Mounting the cabinet.....	25
5.4.1	Mounting the cabinet to a foundation	25
5.4.2	Mounting the cabinet	26
5.4.3	Install cable gland(s).....	26
5.5	Install border covers.....	27
5.5.1	Install border covers of cabinet	27
5.6	Connect cables	27
5.6.1	Connect PE of power cable	27
5.6.2	Connect power cables.....	29
5.6.3	Connect network cables	29
6	Commissioning.....	31
6.1	Commissioning preparation.....	31
7	Cleaning of the cabinet.....	33
7.1	Cleaning of the cabinet.....	33
8	Technical Data.....	34
8.1	Electrical data	34
8.2	Mechanical data.....	35
8.3	Environment	35
8.4	Certifications & Compliance.....	35
9	Contact information	36

Glossary

AC

Alternating Current.

CCS

Combined Charging System. This is the name of the charging protocol of European and North-American car makers.

CHAdeMO

DC fast charging method for electric vehicles.

Contractor

Entity hired by the owner / site operator to do engineering, civil and electrical installation work.

DC

Direct Current.

EV

Electric Vehicle.

Grid provider

Company responsible for the transportation and distribution of electricity.

HMI

Human Machine Interface; the display/screen on the charger.

LTO

Low Temperature Option.

NOC

ABB Network Operating Centre; remotely checks the correct functioning of the charger.

Owner

The legal owner of the charger.

OCPP

Open Charge Point Protocol. Open standard for communication with charge stations.

PE

Protective Earth.

PPE

Personal Protective Equipment. Equipment such as safety shoes, helmet, glasses, gloves.

RCBO

Residual-current Circuit Breaker with Overload protection. Breaks the connection if a residual current or overload is detected.

RCD

Residual Current Device. Breaks the connection if a residual current is detected.

RFID

Radio-Frequency Identification. RFID is a communication technology by means of radio waves to transfer data over a very short distance between a reader and an electronic tag or card.

Site operator

This entity is responsible for the day to day control of the charger. The site operator can be the owner, but not necessarily.

User

The owner of an electric vehicle, who uses the Charge Station to charge that vehicle.

1 Introduction

1.1 Preface

This guide describes the planning and physical installation of the Terra 24 or Terra 54 at its location.

The Terra 24 and Terra 54 Charge Stations are easy to install DC fast chargers for electric vehicles. Fast chargers are electrical installations with high electric currents. Therefore, the installation must be planned carefully, and must be done by certified personnel only (according to local standards).

The Terra 24 is physically the same charger as a Terra 54. The main difference is the output power it can deliver, and therefore also the input power needed. The differences of the Terra 24 and Terra 54, and the consequences for the installation are described in the separate section 1.3.

As the physical installation of both types is equal, they will be referred to hereafter as Terra 54 only and this will account for both types, unless specifically stated otherwise. Both types come in different versions, depending on the outlet types. The different versions are described in paragraph 1.4.

1.2 Intended document users

This document is intended to be used by:

- Customers who purchased a Terra 54, or are in the process of ordering and want to know in more detail how it has to be installed.
- Contractors who are responsible for site preparation and/or installation of a Terra 24 or Terra 54.

1.3 Similarities and differences between Terra 24 and Terra 54

The Terra 24 and Terra 54 chargers are identical in their outer appearance and physical dimensions. The physical installation of the Terra 24 and 54 can thus be handled the same way.

On the inside of the cabinet there are some differences. The Terra 24 delivers 20 kW with 2 DC power converters, while the Terra 54 has 5 converters for a total of 50 kW. The Terra 24 can be upgraded to a Terra 54 in a later stadium if desired. Because of the possibility to upgrade, we advise to dimension the grid connection cable already to the power needed for a Terra 54, if possible/available, to prevent high costs for groundwork when a new cable must be added.

It is only possible to upgrade the DC power output of a Terra 24.

1.4 Terra version description

Terra 24, 54 and 54HV are available in different versions depending on the available outlets. The versions are:

Version	CCS	CCS HV	CHAdeMO
T24/T54 C	X		
T24/T54 CJ	X		X
T54HV C		X	
T54HV CJ		X	X

C CCS (Combo) standard
J CHAdeMO standard
HV High Voltage

1.5 Signs

The following signs are used on the equipment and in this manual:



DANGER
Hazardous voltage
Identifies a hazard that could result in severe injury or death through electrocution.



WARNING
Various
Identifies a hazard that could result in severe injury or death.



WARNING
Rotating parts
Identifies a hazard that could result in injury due to the presence of rotating or moving parts.



WARNING
Pinch Hazard
Identifies a hazard that could result in injuries, in which some body parts are pinched or crushed.



CAUTION

Various

Identifies a hazard that could result in damage to the machine, other equipment, and/or environmental pollution.



NOTICE

Contains remarks, suggestions or advice.

1.5.1 Owner responsibilities

The owner and site operator are required:

- To operate the charge station with the protective devices installed and to make sure all protective devices are correctly installed after carrying out installation or maintenance.
- To write an emergency plan that instructs people what to do in case of emergency.
- To prepare the site where the charge station will be installed, according to the requirements described in this guide.
- To make sure that there is enough space around the charger to carry out maintenance work.
- To appoint a person responsible for the safe operation of the charge station and for the coordination of all work.
- The owner is cautioned that changes or modifications not expressly approved by ABB can void the owner's authority to operate the equipment and ABB's warranty policy.
- Neither ABB nor its affiliates shall be liable to the purchaser of this product or third parties for damages, losses, costs or expenses incurred by purchaser or third parties as a result of: an accident, misuse or abuse of this product, or unauthorized modifications, repairs or alterations to this product, or failure to strictly comply ABB operating and maintenance instructions.

1.5.2 Tilting and handling



WARNING

Heavy equipment

The Terra 54 weighs about 325 kg. Handling Instructions:

1. Use crane, forklift or pallet truck when lifting or moving the Terra 54.
2. Do not drop the Terra 54.
3. Do not exceed a tilting angle of 30°.

1.5.3 Sharp edges



WARNING

Sharp metal edges

There could be sharp metal edges inside the Terra 54. It is recommended to wear mesh protecting gloves when working inside the charger.

1.5.4 Electric hazards



DANGER

Hazardous voltage

The Terra 54 contains conductors under hazardous electrical voltages. The grid terminals on the internal DIN rail may carry hazardous voltages, even if all circuit breakers are switched off.

1.5.5 Installation safety



DANGER

Hazardous voltage

Instructions:

1. Always switch off the external group switch and the main switch in the cabinet, before performing any installation, disassembly, repair or replacement of components.
2. Do a voltage check and make sure that the electrical power is disconnected from the system.
3. Only ABB certified technicians are permitted to commission the Terra.
4. When the system is in an open or dangerous condition, do not allow unqualified persons to go near it. Instruct and warn people about the potential harmful high voltages.
5. The installation and maintenance personnel must supply their own lighting equipment, since the T54 has no lights inside the cabinet.
6. Always connect the Protective Earth (PE) first, before connecting the neutral (N) and Phase (P) wiring.
7. Correctly lock the door after installation or service operations.

1.6 Environment and disposal of waste



NOTICE

Always observe the local rules and regulations with respect to processing (non-reusable) parts of Terra 54.

2 Description of the product

2.1 Overview of the system

2.1.1 Complete overview

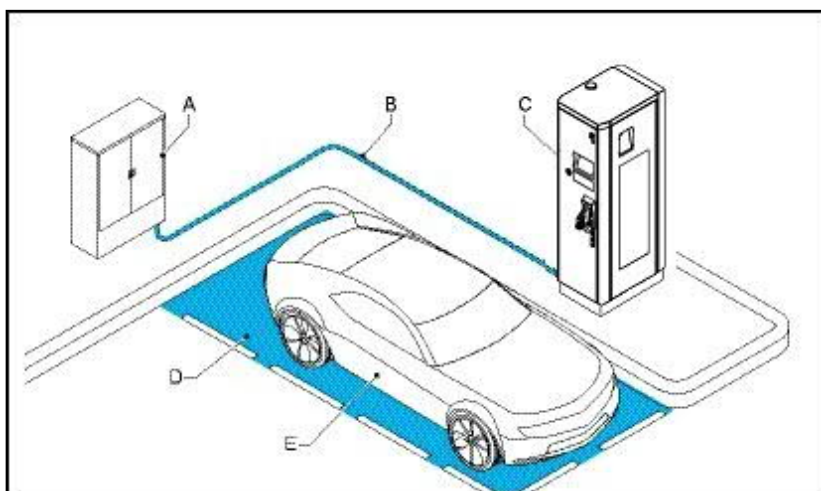

Example of a complete installation

- A Power distribution board of the owner
- B Cables in cable conduit (if required)
- C Terra 54
- D Parking space for charging
- E Electric vehicle

2.1.2 Outside view

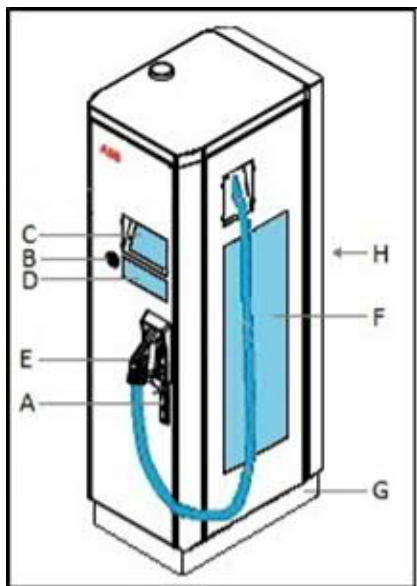

- | | | | |
|---|--------------------|---|--|
| A | Door handle / lock | E | Charge outlet: DC connector and DC cable |
| B | Emergency stop | F | Air inlet |
| C | Display / HMI | G | Border cover |
| D | RFID card reader | H | Air outlet (backside) |

2.1.3 Inside view

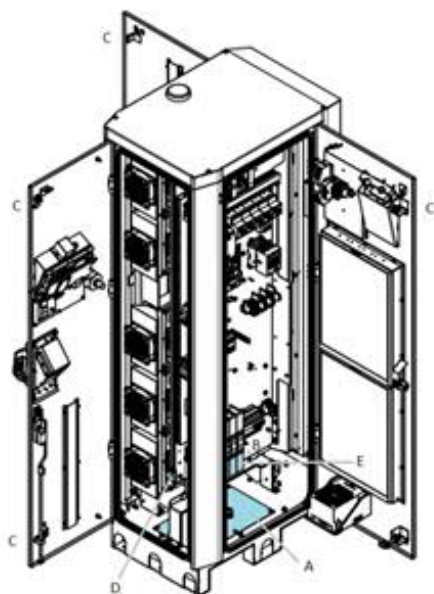

- | | | | |
|---|--|---|-------------------|
| A | Cable gland plate | D | Main switch |
| B | PE connection | E | Power connections |
| C | Door switch (2x on front door, 1x on each side door) | | |

2.2 Geometry of infrastructure

2.2.1 Required space for placing and maintaining the Terra 54

The Terra 54 requires a space of 1585 x 1480 mm. This space is calculated as follows:

- Size Charger W x D x H: 565 x 780 x 1900 mm.
- Front side 600 mm, in order to open the front door.
- Left and right side 510 mm, in order to open left and right door.
- Backside 100 mm, in order to guarantee an unimpeded airflow.

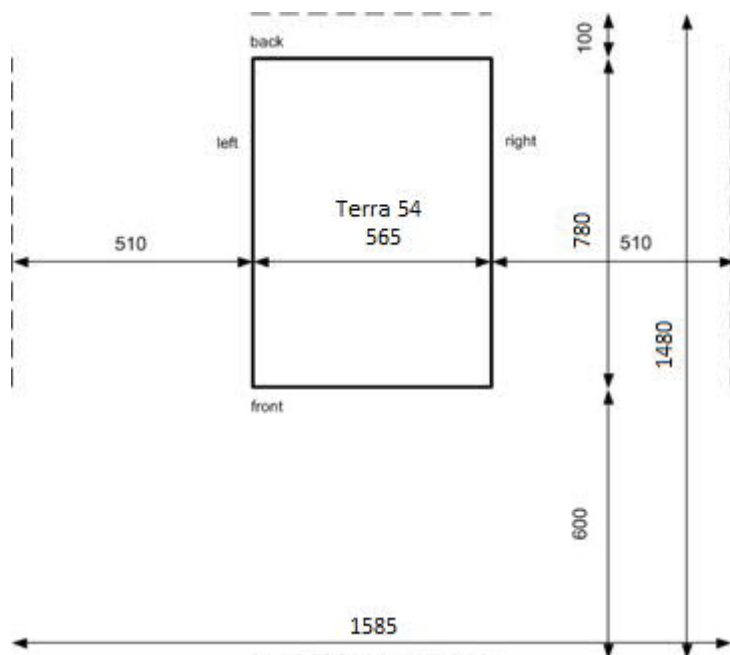

2.2.2 Ventilation and airflow of the Terra 54

The Terra 54 has an air inlet on the right side and outlet on the back side.



NOTICE

Free air flow

If necessary, take precautions to prevent snow or objects from blocking the in- and outlets.

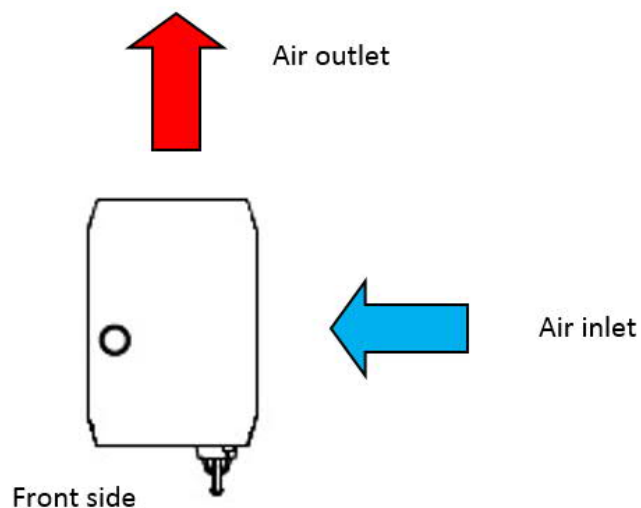

Angled front view:

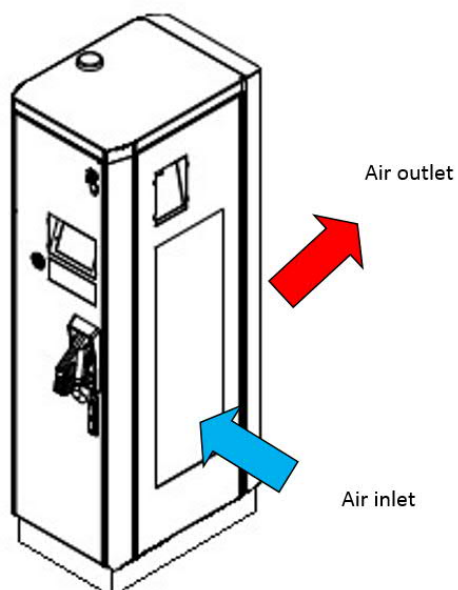

2.2.3 Bollards

It is advised to place bollards around the charger to protect the charging station against cars hitting and damaging the cabinet.



NOTICE

Bollards limiting the access

When installing bollards around the charger make sure all doors can still be opened to be able to service the charger. In case bollards are installed that are blocking the doors, make sure they are the removable kind. The key must be available for service engineers. Also, the accessibility of the charger for wheelchair users should be considered when placing bollards around it.

2.3 Electrical engineering

The electrical installation must be completed according to the local safety and electrical regulations and laws. A single-line diagram for the electrical connections with the main safety components inside the charger is shown in the figure below.

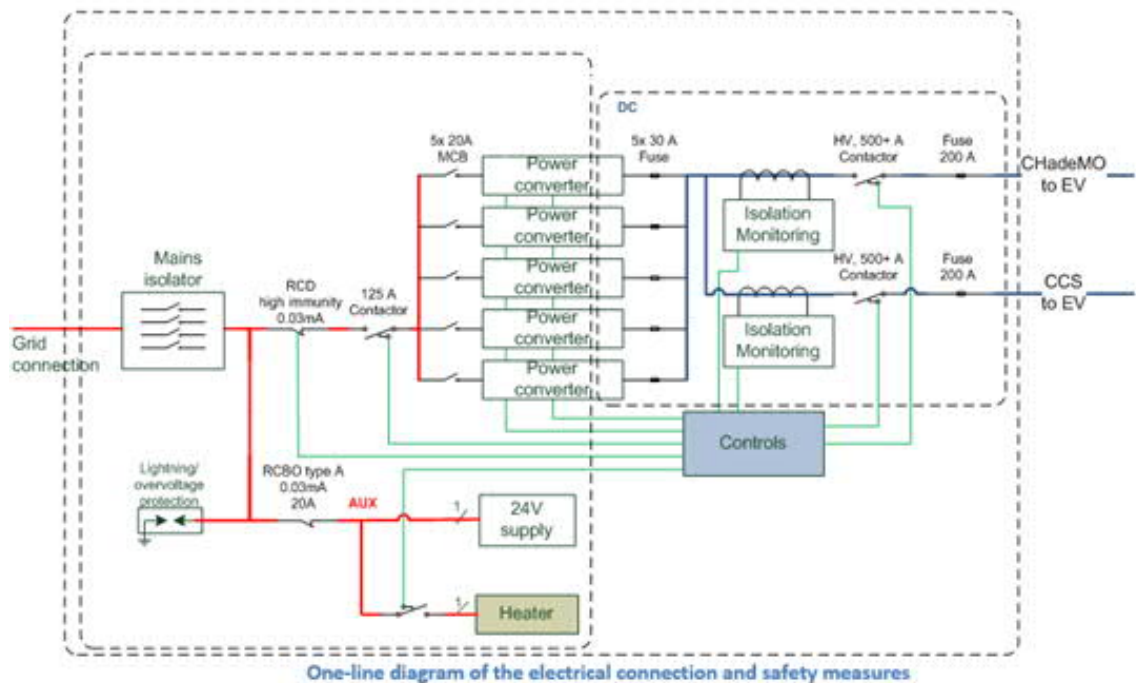

2.3.1 Requirements External RCD



NOTICE

External RCD not included in delivery scope
Upstream RCDs are explicitly excluded from ABB's delivery scope and belong to the scope of the installation company. The locally certified installation company can base the RCD device type, amongst other external factors, on below charger characteristics.

In case the local authorities prescribe the installation of an upstream RCD, there are the following factors to take into account in selecting an RCD device of your choice.

DC-charging side requires immunity for short current peaks over PE

When the charger engages the DC charging (at the beginning of every charge session in the pre-charge phase) a relay switches and turns on the input to the power modules. Asynchronous engagement of the phases in the relay in combination with the electrical capacity in the input power part, can cause incidental very short (25 microseconds) current peaks of up to 60 A over the Protective Earth. The amplitude of the electrical current peaks can vary with the location and is dependent on grid and earth impedances. Given the switching characteristics of the DC section of the charger, ABB advises to select an RCD that has proven to be able to withstand these short current peaks (high immunity). As a suggestion to the installation company, ABB recommends the following RCD type, which will work in most grid situations: (1) ABB make F204 B S-125/0,3 code: 2CSF204823R3950. It is the responsibility of the installation company to select the correct device.



CAUTION

Responsibility to comply with local regulations
The installation company is responsible to design and install the electrical installation according to the local regulations.

2.3.2 Conductor and cable diameter

The diameter of the electrical conductor of the ground cables depends on the length, method of installation, etc. This must be determined by the contractor.

The phases are to be mounted with mechanical on the incoming disconnect switch. The maximum diameter of the conductor is AWG 2/0 (70 mm²).

The maximum overall diameter of the (grid) cable entering the cabinet is 45 mm. The minimum diameter with the standard fitted cable gland insert is 34 mm.

3 Site design

A site for EV charging can be designed in many different setups. This section is intended to give some useful information on the placement of a charger with respect to parking spaces and the vehicle inlets for the charging cable.

3.1 Cable reach

The charge cables of the T54 are about 3.9 meters long. The (optional) CHAdeMO cable leaves the charger on the right side, the CCS cable leave on the left side. The cables and the connectors mounted on the cables are physically different for each charging standard and make them more or less flexible to reach out.

The figure below shows the charger in the center with each type of connector and how far it can reach out. The yellow circle describes the range of the CCS cable, green circle the CHAdeMO cable, blue circle the AC cable (AC cable not applicable in NAM version).

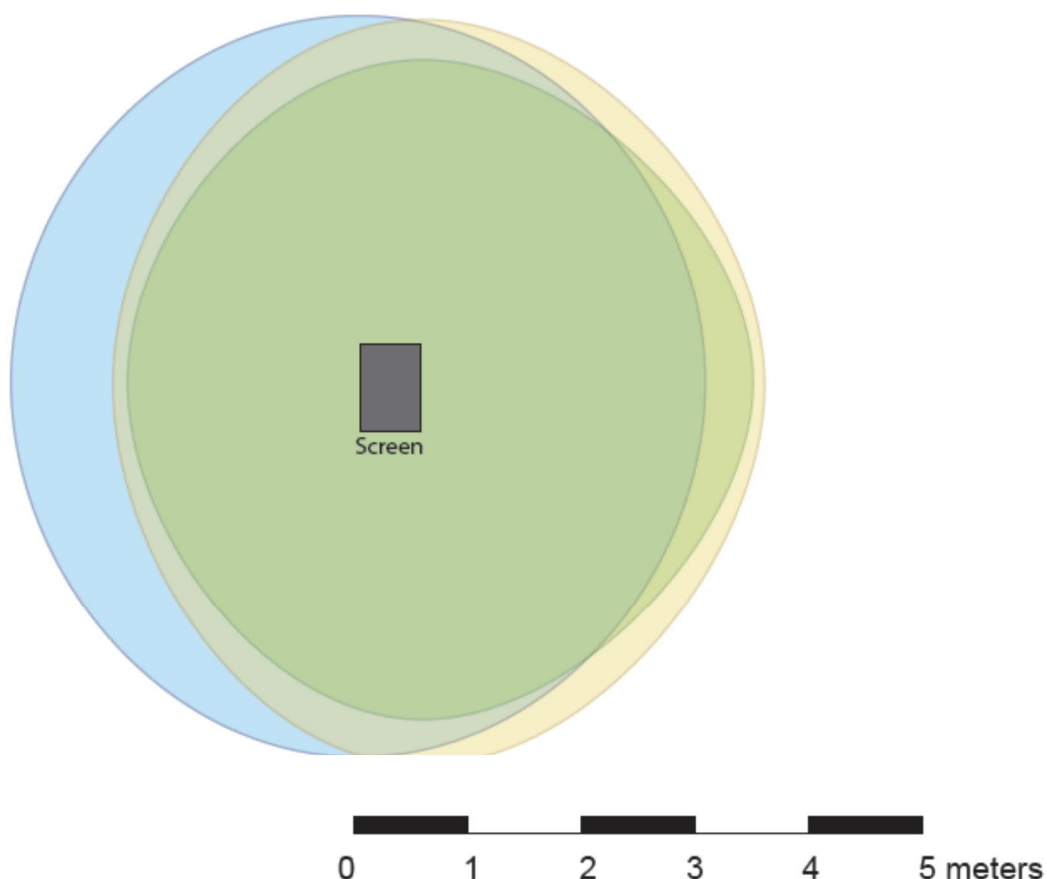

3.2 Different alignment possibilities

The charge inlets on a car can be located at different positions. The most common cars have their inlets located either on the front of the car, or on the left or right back side.

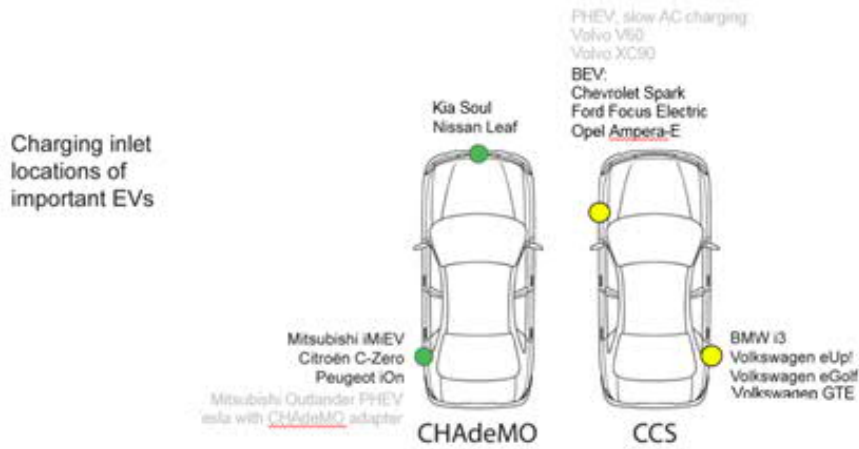

This makes some positions of the charger with respect to the parking space more favorable than others. Please keep this in mind when designing a site. Some possible situations are showed below:

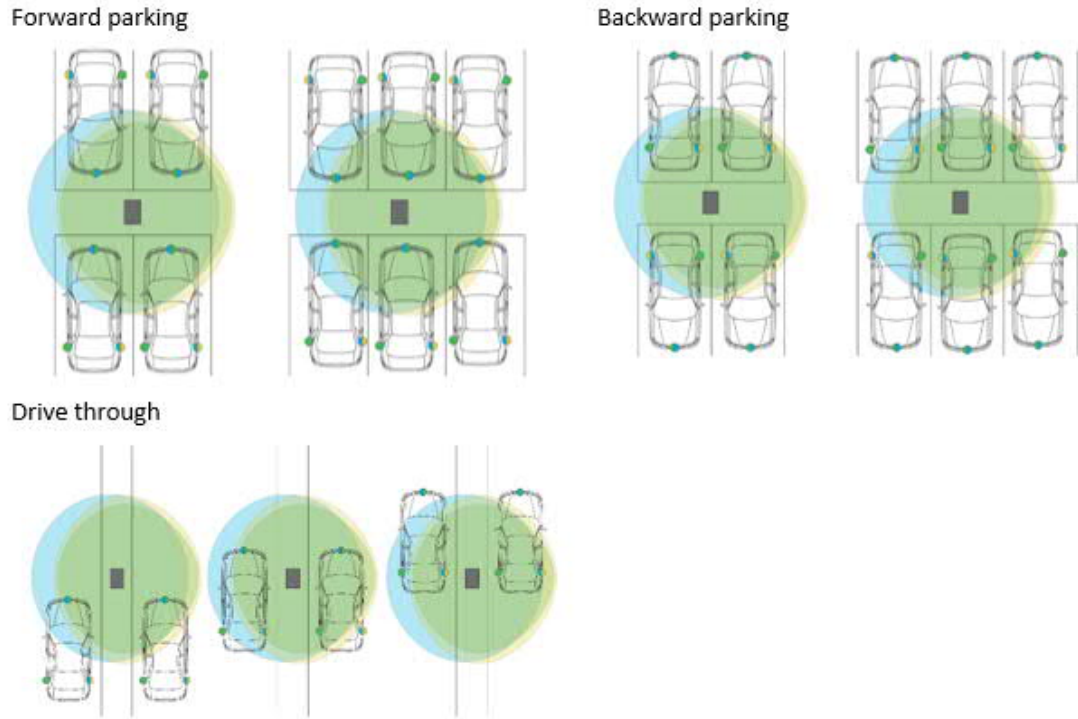

4 Site construction

4.1 About construction

The construction phase includes all work required to prepare the location and make it ready for the placement and connection of the Terra 54. The construction phase can start when:

- All preparation engineering work is done.
- All necessary permits are granted.
- The grid connection is available.

4.2 Power feed

The power cable enters the charger from below. Use foam or proper cable lugs/glands to prevent the small animals to enter the cabinet from the AC/Ethernet inlet.

4.3 Construct foundation

The only option when the charger is placed on soil is through the construction of a custom-built foundation.

Depending on the situation and cable type, the cables must be embedded in the ground with or without a cable duct. Follow these instructions for the custom foundation footprint:

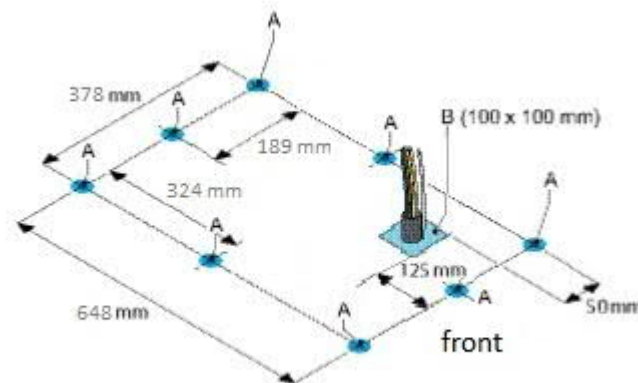

1. Drill and tap 8 holes (minimum recommended 3/8" or M10, 5/8" is common) in the floor at the indicated positions (A), depth ± 60 mm.
2. Make sure that the cables come out of the floor within the marked area (B).
3. Make sure that a cable length of one meter is available above the floor for internal routing in the cabinet.

4.4 Power cable

- Cable type: 3P+PE; shielded cables are optional if not required by local law.
- Optional cable shielding must be attached to the PE rail at both ends of the cable.
- The diameter of the cable conductor must be determined by your contractor / electrician.
- The maximum diameter surface of the cable conductor is 300 MCM (0.63”).
- The PE conductor of the power cable must have the same diameter as the phase conductors.

4.5 Internet connection

The preferred method of communication is to use the wireless 2G/3G modem that is integrated into the Charger. A customer SIM card is not required, a subscription for the SIM card is provided by ABB for selected countries.

If there is no wireless signal available, a standard wired internet connection is required. This connection must meet the following requirements:

- Ethernet, RJ45.
Cable type: 8P+PE, shielded.
- Recommendations:
For distances of 75 meters or less; HELUKAT 600E.
Distances over 75 meters require a custom engineered project.
- Recommended minimum bandwidth:
Upload: 128 kb/s
Download: 4 Mb/s.
- Recommended availability: 99.9%.
- The connection must be available for the ABB service engineer and the NOC.
- Please contact ABB for a specific configuration.

In case the separate internet connection is not used, please assure the cable entry hole is closed, to assure the IP54 grade of the cabinet, and prevent insects and small animals to enter the cabinet.

5 Receiving, Placing and connecting

5.1 Receiving the cabinet

The product is delivered by a transport company to a warehouse where it will be handed over.

Transporting the Terra 54 to its final location (last mile service) is not standard included in the order.



NOTICE

The delivery truck unloads the pallet carrying the Terra 54. The movement of the Terra 54 to its final location is the responsibility of the customer / contractor.

Check whether the Terra 54 has not been shaken or tilted.

- The cabinet is equipped with Shockwatch and Tiltwatch indicators.

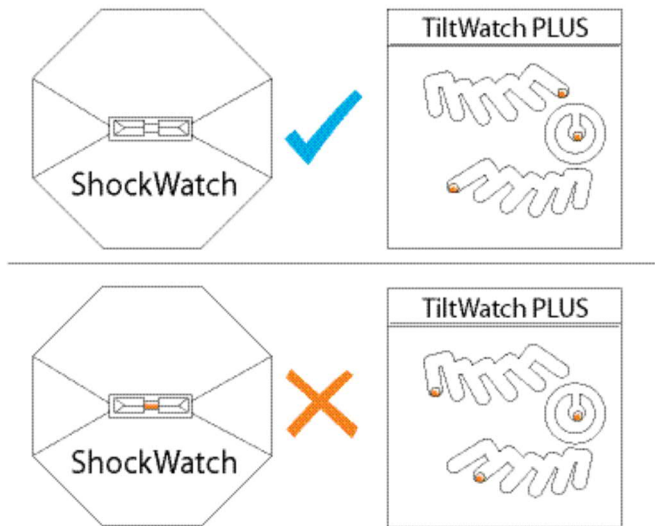

Checking the Shockwatch and TiltWatch PLUS sensors:

If the ShockWatch indicator is red, or the TiltWatch PLUS indicator is tilted over 30°:

1. Do not refuse the delivery / receipt.
2. Make a note on the delivery receipt and inspect cabinet for damage.
3. If damage is discovered, leave cabinet in original package and request immediate inspection from carrier and notify ABB within 3 days of delivery.

5.2 Unpacking cabinet, mounting preparations

5.2.1 Unpacking

The packaging of the Terra 54 can be removed without the use of tools.



1. Remove the outside shrink wrap.
2. Remove the plastic protection profiles.
3. Remove the innerside shrink wrap.

5.2.2 Mounting preparations

Remove border covers (base frame "skirt")

Preconditions:

- Tools: Allen key size 4.

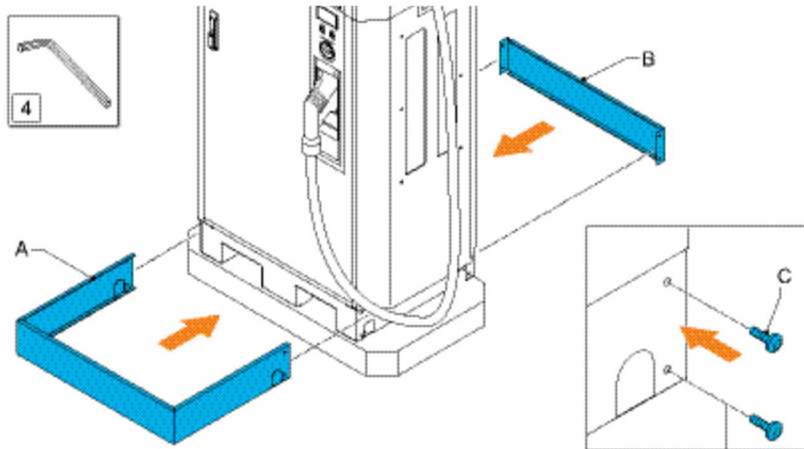

1. Remove the bolts (C) of the border covers.
2. Remove the U-shaped covers (A, B) off the base of the Terra 54.

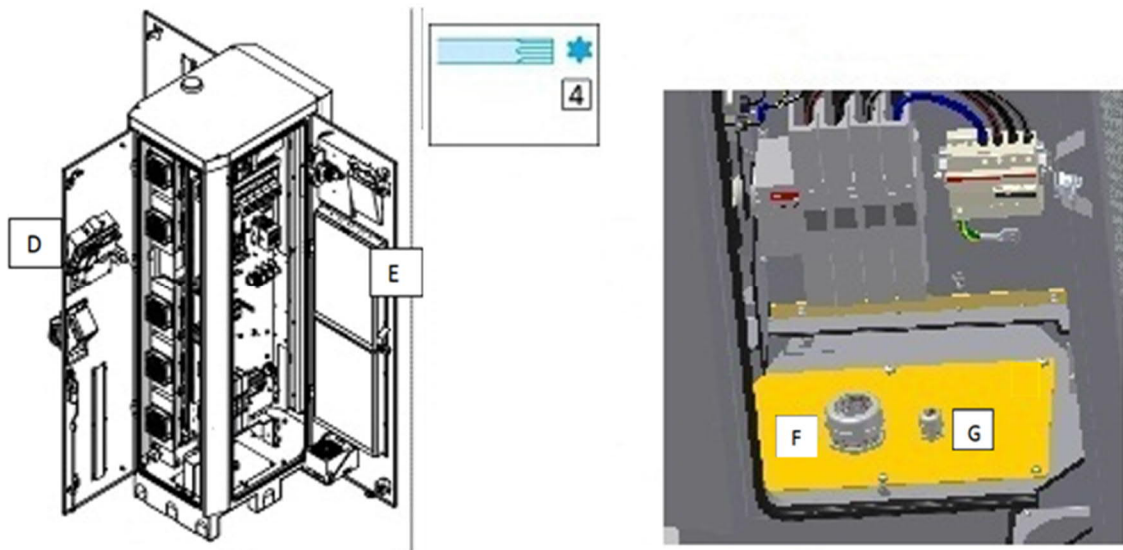

3. Open the cabinet front door (D).
4. Open the side door (E) via the front door.
5. Loosen and remove the cable gland (F) for the power cable.
6. Loosen and remove the cable gland (G) for the Ethernet cable (if required).
7. Put the cable gland(s) in a safe location. It (they) will be re-installed later.

8. Close the doors, starting with the side door and subsequently the front door.

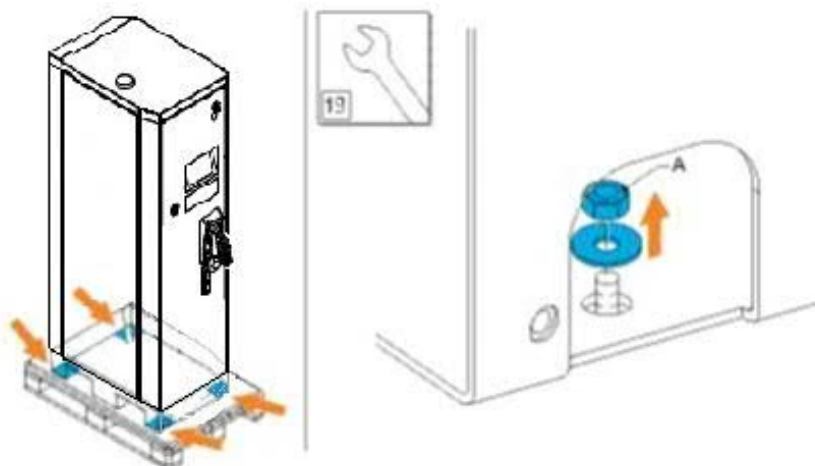

9. Remove the nuts (A) at the four corners.

5.3 Move cabinet to position

5.3.1 Options

There are two options to move the Terra 54 from the delivery truck to the location.

- Move cabinet with hoist, see section 5.3.2.
- Move cabinet with forklift truck, see section 0.



DANGER

Hazardous voltage

Make sure the main switch of the power supply group for the product is set to the OFF position. Do a voltage check to make sure there is no electrical power on the cables or on the system.



NOTICE

Warranty

Damage due to moving the cabinet to its position is not considered a warranty issue.

5.3.2 Move cabinet with hoist

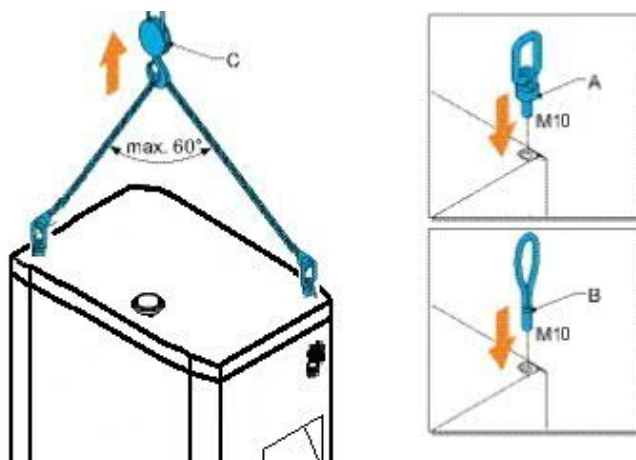

- A Swivel eye bolts
- B Lifting loops
- C Hoisting equipment

Preconditions:

- Use swivel eye bolts (A) or bolts with lifting loops (B). (ie: McMaster 3040T14)
1. Insert and tighten the bolts (A) or (B) at opposite corners.
 2. Connect the hoisting equipment (C).
 3. Move the Terra 54 carefully to its location.



WARNING
Various
Keep the hoisting angle below 60°.

Swivel eye bolts, lifting loops and hoisting equipment are not part of the delivery.

5.3.3 Move cabinet forklift truck

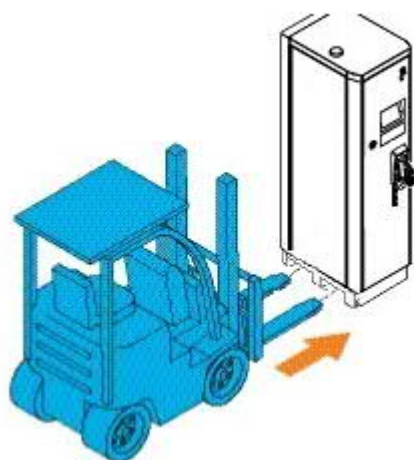

1. Move the forks of the forklift truck in the gaps at the side of the Terra 54.
2. Move the Terra 54 carefully to its location.

5.4 Mounting the cabinet

Preconditions:

- Tools: Spanners size 17.
- The Terra 54 is about 0.5 m above its location
- Open the front door and right side panel.
- Guide the power cable through the cable gland and if required the Ethernet cable through the smaller gland.

5.4.1 Mounting the cabinet to a foundation

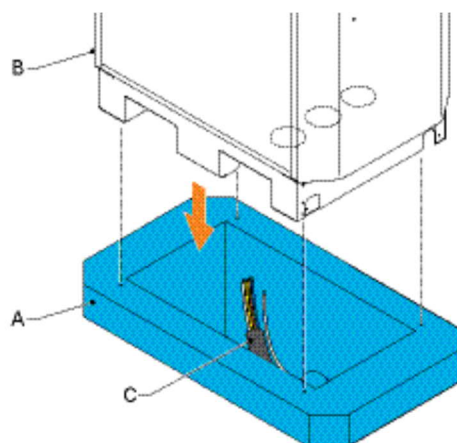

Placement on a concrete foundation

- A Foundation
- B Terra 54
- C Cables

5.4.2 Mounting the cabinet

1. Carefully lower the Terra 54 onto its location.
2. Make sure not to entrap the cable(s).
3. Make sure that the cabinet is aligned to the tapped holes.

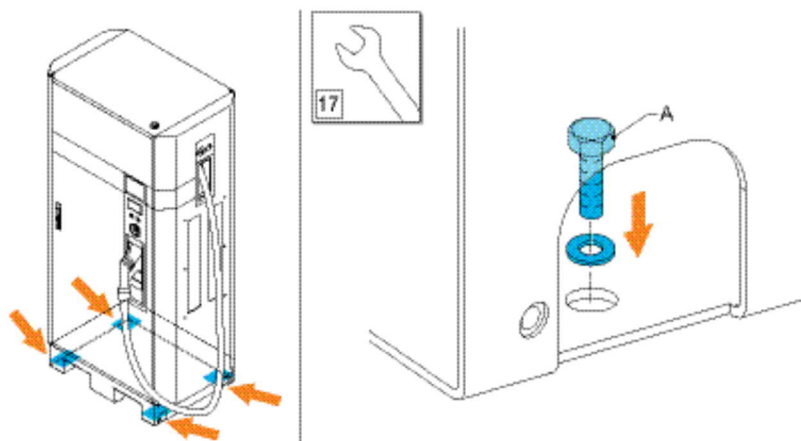

4. Insert bolts (A) and washers at the four corners and in the middle of the sides.
5. Tighten the bolts.

5.4.3 Install cable gland(s)

The maximum diameter of the grid cable is 45 mm.

The minimum diameter of the grid cable is 34 mm with the standard fitted cable gland insert.



1. Slide the cable gland(s) over the cable(s).
2. Push the cables back through the gland plate, until sufficient cable length is left to reach the cable terminals, make sure the PE cable is longer than the other cables.
3. Tighten the rings of the gland(s).

In case the separate internet connection is not used, please assure the cable entry hole is closed, to assure the IP54 grade of the cabinet, and prevent insects and small animals to enter the cabinet.

5.5 Install border covers

5.5.1 Install border covers of cabinet

Preconditions:

- Tools: Allen key size 4.

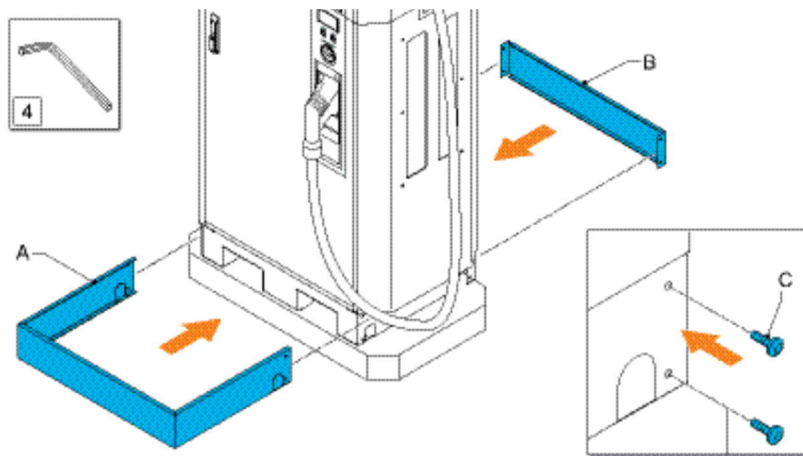

1. Put the small cover (B) against the back of the Terra 54.
2. Put the U-shaped cover (A) on the base of the Terra 54 from the front. The U-shaped cover overlaps the sides of the small cover.
3. Insert and tighten the bolts (C) at both sides.

5.6 Connect cables

5.6.1 Connect PE of power cable

Preconditions:

- Tools: Wire stripper pliers; wire-end lug pliers; wire-end lug.



DANGER

Hazardous voltage

Make sure that the main switch of the power supply group for the product is set to the OFF position. Perform a voltage check and make sure that the electrical power is disconnected from the system.

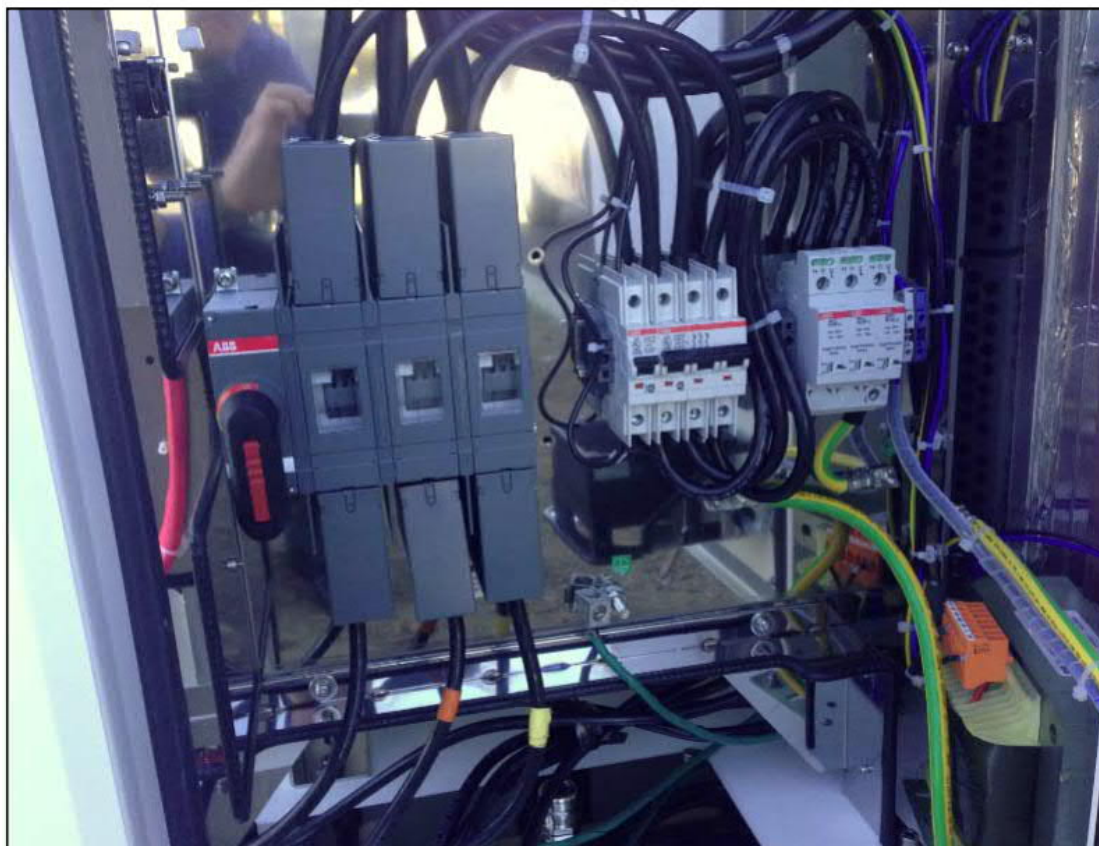

1. Cut the PE wire of the power cable to the correct length to reach the PE connector.



NOTICE

For safety, it is recommended to make the PE wire longer than the phase wires. This makes sure that the PE wire stays connected longest in case the Terra 54 is moved by a collision.

2. Use wire stripper pliers to remove 20 mm of the insulation from the end of the PE wire.
3. Attach a cable lug to the end of the PE wire.
4. Loosen the bolt of the PE connector.
5. Attach the PE wire onto the PE connector.
6. Tighten the bolt.

GROUNDING INSTRUCTIONS – This unit is to be connected to a grounded, metal, permanent wiring system; or an equipment-grounding conductor is to be run with circuit conductors and connected to equipment-grounding terminal or lead on battery charger. Connections to battery charger shall comply with all local codes and ordinances.

5.6.2 Connect power cables

Preconditions:

- Tools: Wire stripper pliers; wire-end lug pliers; wire-end lugs.



DANGER

Hazardous voltage

Make sure that the main switch of the power supply group for the product is set to the OFF position. Perform a voltage check and make sure that the electrical power is disconnected from the system.

1. Cut the 3 phase and wires of the power cable to the correct lengths to reach the connectors.
2. Use wire stripper pliers to remove 20 mm of the insulation from the ends of the wires and attach the cable lugs.
3. Pull the covers away from the connectors and remove them.
4. Loosen the bolts of the connectors.
5. Attach the three wires onto their connectors.
6. Tighten the bolts. The advised torque value ranges between 15 and 20 Nm.
7. Install the covers back onto the connector.



WARNING

Leave the main switch switched off. The Terra 54 is not ready for use yet. Please contact the ABB Service department at least one week in advance to make an appointment for commissioning.

5.6.3 Connect network cables

See section 4.5 as 2G/3G is preferred.



NOTICE

Only connect the network cable if a wireless 2G/3G connection is not possible.

Preconditions:

- Tools: Network cable pliers, RJ45 connector; network cable.



1. Cut the network cable to the correct length to reach the Ethernet connector. The connector is located behind the right side door, near the bottom of the charger.
2. Use network cable pliers to install an RJ45 connector on to the network cable.
3. Insert the RJ45 connector into the Ethernet connector.

6 Commissioning

6.1 Commissioning preparation

Commissioning is the last step necessary to get the Terra 54 operational. The purpose is to check the safe functioning of the charger for its operational purpose.

A certified service engineer from the ABB Service department or a trained engineer by ABB is required to perform the commissioning. During this commissioning the safety and the functioning of the charger will be tested.

Before the service engineer can start, the following conditions must be met:

- All work described in Preparation (see section 3), Construction (section 4) and Placement and connection (section 5) is completed.
- Power is available.
- A local technician is present for assistance and to switch on the power.
- Internet access must be available in case 2G/3G is not functional.
- It is highly recommended that SAE CCS compliant EV and CHAdeMO compliant EV to be available for test charging and guiding station owner/operator.



NOTICE Warranty

It is not allowed to move the Terra 54, after it is commissioned.

In case the Terra 54 is moved without approval from ABB, the warranty will be considered void. In case of relocation please contact the local ABB Service department.

Commissioning is executed according to the commissioning procedure, which can be found in the Helios Suite Service tool that is available to the certified commissioning engineers or their supervising ABB organisation. Also the following data is required for input:

- End-user Contact person (Create a contact if it doesn't exist).
- Charger address (Check the mentioned address, it will be the address the charger was shipped to).
- Coordinates longitude and latitude for plots on the maps. If there are more chargers on 1 location, make sure the coordinates are slightly different (at least 0.0001 degrees) to prevent being displayed on the same location.
- Site name if this is useful for better recognition (e.g. Shell petrol station Amsterdam).
- External fuse of the charger.
- SAT (Site Acceptance Test) date.



- Location remarks (any special remarks about the site, e.g. behind a gate, no photo cameras allowed, etc.)
- Add a picture of the surrounding of the charger, upload the local CAF document A4 on the page of the charger in PDF-format.
- Change Deliver status to <SAT>.

After completing the Site Acceptance Test, ABB's Network Operation Center will be triggered to perform a final check on the connection and configuration of the charger.

Upon approval the charger will be operational and initialized for use.

7 Cleaning of the cabinet

7.1 Cleaning of the cabinet

The Terra 54 Charge Station is powder coated. This coating must be kept in good condition.

Clean the Terra 54 Charge Station three times a year in the following way:

- Remove rough dirt by spraying with low-pressure tap water.
- Apply a neutral or weak alkaline cleaning solution and let it soak.
- Remove dirt by hand with a non-woven nylon cloth hand pad.
- Rinse thoroughly with tap water.
- Optionally, apply wax on the front for extra protection and gloss.
- Do a check on the coating for damage.
- When using labels (foiling) on the charger, refer to the label manufacturer's instructions of how to clean them.
- In case of removing labels (foiling) from the charger, don't do this with a cold or freezing ambient temperature and heating gun because you risk removing part of the powder coating layer, too. Remove labels only on a warm day.



NOTICE

When the Terra 54 Charge Station is exposed to rain, it is sufficient to clean it twice a year.



CAUTION

Do not apply high-pressure water jets. Water may leak into the Terra 54 Charge Station. If a high-pressure water jet has been used, make sure that the inside of the Terra 54 Charge Station is dry.

- Only use cleaning agents with a pH value between 6 and 8.
- Do not use cleaning agents with abrasive components.
- Do not use abrasive tools.

8 Technical Data

8.1 Electrical data

Input	
Supply voltage	3 phase, 480Y/277V AC: 3P+PE <small>(no Neutral connected)</small>
Input voltage range	480 V AC +/- 10% (60 Hz)
Maximum rated input current & power	64 A, 54 kVA
Power factor	> 96%
Efficiency	95% at nominal output power
DC output (C)	
Maximum output power	50 kW
Output voltage range	200-500 V DC (CCS Combo-1)
Maximum output current	125 A DC (CCS Combo-1)
DC output (C HV)	
Maximum output power	50 kW
Output voltage range	200-920 V DC (CCS Combo-1)
Maximum output current	125 A DC (CCS Combo-1)
DC output (J)	
Maximum output power	50 kW
Output voltage range	200-500 V DC (CHAdeMO)
Maximum output current	125 A DC (CHAdeMO)
General	
DC connection standard	EN61851-23 / DIN 70121 / SAE J1772 CCS Combo-1/ CHAdeMO 1.0
DC cable length	3.9/6.5 meters
DC plug type	SAE J1772 Combo-1 / JEVS G105 CHAdeMO
RFID data	
RFID system	ISO/IEC 14443A/B, ISO/IEC 15693, FeliCa™1, NFC reader mode, Mifare, Calypso (option: Legic)
Network connection	GSM / 3G modem, 10/100 Base-T Ethernet

8.2 Mechanical data

Mechanical data	
Dimensions (H x W x D)	1900 mm x 565 mm x 780 mm (74.80 x 22.25 x 30.71 in)
Weight	325 kg (717 lbs)
Dimensions including packaging (H X W x D)	2100 mm x 1200 mm x 800 mm (83 x 48 x 32 in)
Weight including packaging	Domestic LTL: 400 kg (900 lbs) Air/Sea Freight: 500 kg (1100 lbs)
Mechanical impact protection	IK10, display IK08
Housing	Stainless steel 430

8.3 Environment

Environmental data	
Ingression protection	IP54 (NEMA 3R)
Temperature range – Operation	Without LTO: -10 °C to +50 °C (14 °F to 122 °F) With LTO: -35 °C to +50 °C (-31 °F to 122 °F)
Temperature range - Storage	-40 °C to +70 °C (-40 °F to 158 °F)
Humidity	20% - 95% RH - non-condensing
Operational noise level	Typical 45 dBA, worst case 70 dBA
Altitude	Max. 2500 m above sea level

8.4 Certifications & Compliance

Terra 54

Certified to UL 2202 by TUV	Cert. # TU 72181310 01
Certified to CSA C22 .2 NO. 107.1-16 by TUV	Cert. # CA 72181465 01

Terra 54 HV

Certified to UL 2202 by TUV	Cert. # CU 7211649 01
Certified to CSA C22 .2 NO. 107.1-16 by TUV	Cert. # CU 7211649 01



Other certifications

- CHAdeMO 1.0
- ISO/IEC15693
- ISO/IEC14443A/B
- FCC 47 CFR Part 15 B

9 Contact information



NOTICE

In case of problems

Please contact your local ABB Service organization or Service partner for first line problem analysis and solving. In case they cannot solve the problem, they will contact the second line Service organization.

ABB Inc.
4050 E. Cotton Center Blvd
Phoenix, AZ 85040
United States
Phone: 1-800-435-7365
E-mail: US-evci@us.abb.com

ABB Inc.
800 Hymus Boulevard
Saint-Laurent, QC H4S 0B5
Canada
Phone: 1-800-435-7365
E-mail: CA-evci@abb.com