

ChargePoint® CP6000 Series — Fleet

Specifications and Ordering Information



Dual port, pedestal mount, 23 ft cable

Ordering Information

The order codes below represent specific product configurations. Please contact ChargePoint Sales for additional information.

Specify model number followed by the applicable code(s).

The order code sequence is: **Model-Options. Software, Services** and **Other** are ordered as separate line items.

Hardware

Description		Order Code
Model	80A Dual port, pedestal mount, 23 ft cable	CP6021X-80A-L7
	80A Single port, pedestal mount, 23 ft cable	CP6011X-80A-L7
	80A Dual port, wall mount, 23 ft cable	CP6023X-80A-L7
	80A Single port, wall mount, 23 ft cable	CP6013X-80A-L7
Other	Bollard Concrete Mounting Kit	CP6K-CMT-NA

Software and Services

Description	Order Code
ChargePoint Power Plan	CPCLD-POWER- <i>n</i> *
ChargePoint Enterprise Plan	CPCLD-FLEETENT- <i>n</i> *
ChargePoint Fleet Commercial	CPCLD-FLEETCOMM- <i>n</i> *
ChargePoint Assure	CP6000-ASSURE- <i>n</i> *
Station Activation and Configuration	CPSUPPORT-ACTIVE
ChargePoint Site Validation	CPSUPPORT-SITEVALID
ChargePoint Installation and Validation	CP6000-INSTALLVALID

Note: All CP6000 stations require a network service plan per port.

*Substitute *n* for desired years (1, 2, 3, 4 or 5 years)

Architectural Drawings and Dimensions

Pedestal Mount

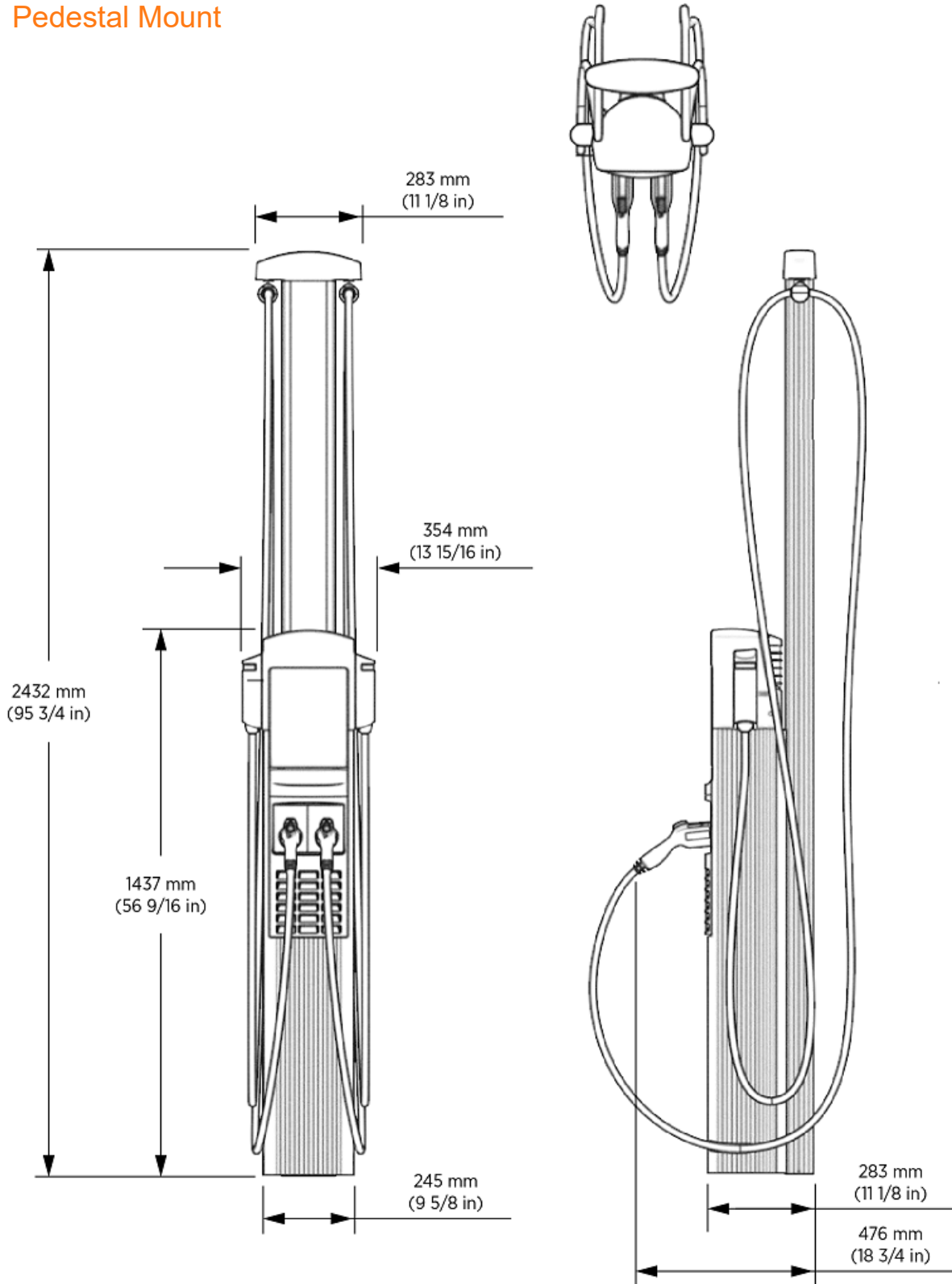

Wall Mount

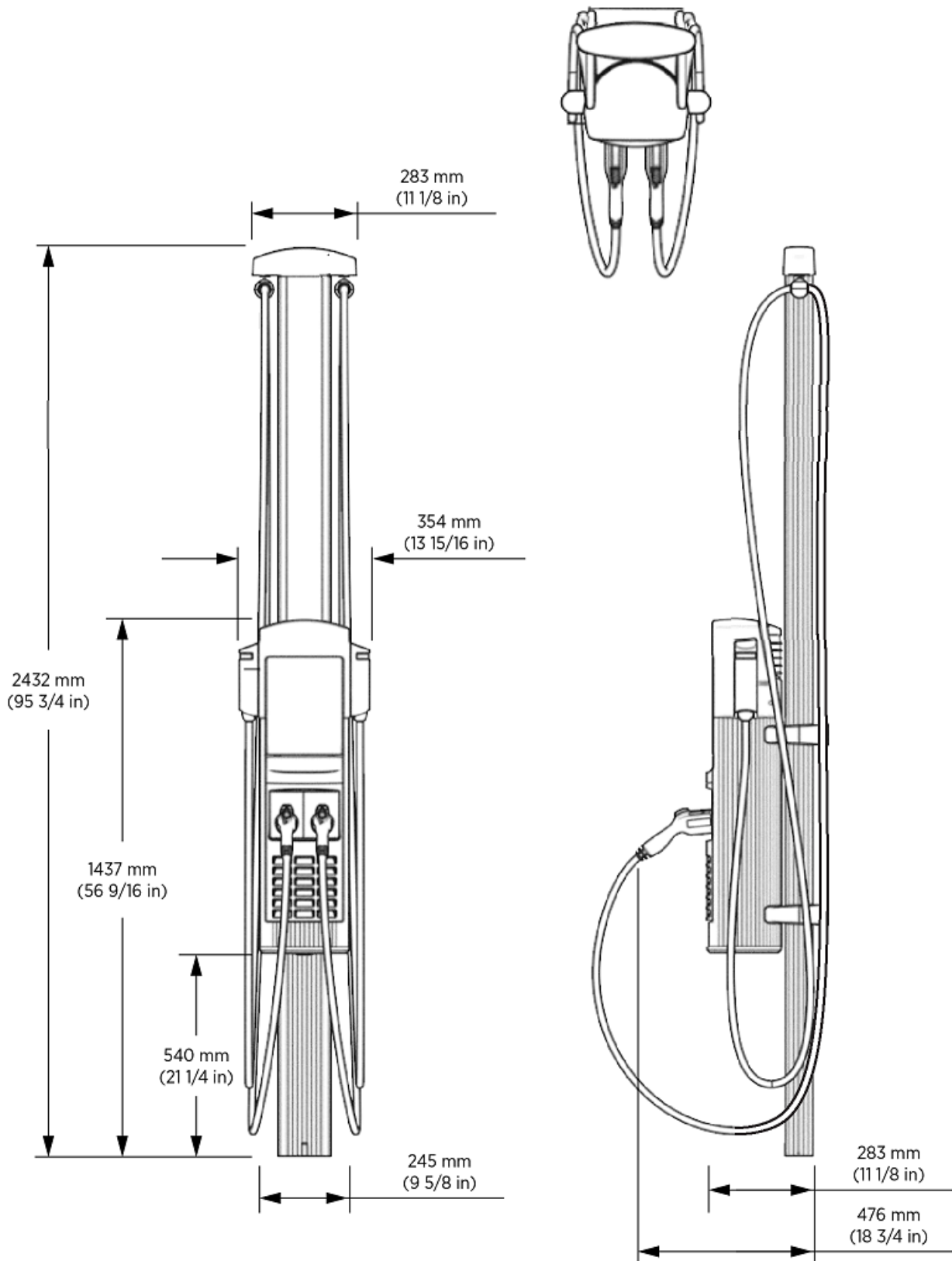

General Specifications

Electrical Input

The CP6000 supports flexible wiring and power settings up to 80A. Power Select allows stations to be installed and configured for current lower than the maximum 80A. Power Select current options include 40A, 48A, 56A, and 64A.

Power Share allows a dual-port station to share power from a single circuit across two ports, adjusting power depending on whether one or both are charging. Standard wiring uses an independent circuit for each port. Power Share can be used in combination with Power Select.

Electrical Input	Single Port (AC Voltage 208 / 240V AC)			Dual Port (AC Voltage 208 / 240V AC)		
	Input Current	Input Power Connection	Required Service Panel Breaker	Input Current	Input Power Connection	Required Service Panel Breaker
Maximum 80A (Standard)	80A	One 100A branch circuit	100A dual pole (non-GFCI)	80A x 2	Two independent 100A branch circuits	100A dual pole (non-GFCI) x 2
Maximum 80A (Power Share*)	N/A	N/A	N/A	80A	One 100A branch circuit	100A dual pole (non-GFCI)
Power Select** 40A - 64A (Standard)	40A - 64A	One branch circuit rated 125% of input current (50A - 80A)	Dual pole (non-GFCI) rated 125% of input current (50A-80A)	40A - 64A x 2	Two independent branch circuits rated 125% of input current (50A - 80A)	Dual pole (non-GFCI) rated 125% of input current x 2
Power Select 40A - 64A (Power Share)	N/A	N/A	N/A	40A - 64A	One branch circuit rated 125% of input current (50A - 80A)	Dual pole (non-GFCI) rated 125% of input current (50A - 80A)
Service Panel/Breaker GFCI	Do not provide external GFCI as it may conflict with internal GFCI (CCID)					
Wiring – Standard	3-wire (L1, L2, Earth) No neutral			5-wire (L1, L1, L2, L2, Earth)		
Wiring – Power Share	N/A			3-wire (L1, L2, Earth)		
Line to Ground Voltage	120V +/- 10%					

Electrical Output

Electrical Output	Single Port (AC Voltage 208 / 240V AC)	Dual Port (AC Voltage 208 / 240V AC)
Maximum 80A (Standard)	19.2 kW (240V AC @ 80A)	19.2 kW (240V AC @ 80A)
Maximum 80A (Power Share)	N/A	19.2 kW (240V AC @ 80A) x 1 or 9.6 kW (240V AC @ 40A) x 2
Power Select 40A - 64A (Standard)	9.6 kW – 15.4 kW (240V AC @ 40A - 64A)	9.6 kW - 15.4 kW (240V AC @ 40A - 64A) x 2
Power Select 40A - 64A (Power Share)	N/A	9.6 kW - 15.4 kW (240V AC @ 40A - 64A) x 1 or 4.8 kW – 7.7 kW (240V AC @ 20A - 32A) x 2

Mounting and Functional Interfaces

Connector Type	SAE J1772™
Number of Ports	Single, dual
Mounting	Pedestal, wall
Cable Length	23 ft (7 m)
Cable Management	Yes
Authentication	RFID: ISO 15693, ISO 14443, NEMA EVSE 1.2-2015 (UR) NFC (Tap to Charge) Remote: mobile and in vehicle (if supported by vehicle)
Locking Holster	Yes
ISO 15118	Supported by hardware

Safety and Connectivity Features

Ground Fault Detection	20 mA CCID with auto retry
Open Safety Ground Detection	Continuously monitors presence of safety (green wire) ground connection
Plug-Out Detection	Power terminated per SAE J1772™ specifications

ChargePoint® CP6000 Series — Fleet

Power Measurement Accuracy	+/- 2% from 2% to full scale
Power Report/Store Interval	15-minute interval aligned to hour. Responsive to load management signals.
Local Area Network	Wi-Fi 2.4 GHz and 5GHz (802.11 a/n/b/g)
Wide Area Network	LTE Category 4
Network Communication Protocol	OCPP 2.0.1
Ethernet connection	Capable with accessory

Safety and Operational Ratings

Station Enclosure Rating	Type 3R
Safety and Compliance	UL and cUL listed; complies with UL 2594, UL 2231-1, UL 2231-2, and NEC Article 625
Station Surge Protection	6 kV @ 3,000A. In geographic areas subject to frequent thunderstorms, supplemental surge protection at the service panel is recommended.
EMC Compliance	FCC Part 15 Class B
Operating Temperature	-40°C to 50°C (-40°F to 122°F)
Non-Operating Temperature	-40°C to 60°C (-40°F to 140°F)
Terminal Block Temperature Rating	105°C (221°F)
Operating Humidity	Up to 85% @ 50°C (122°F) non-condensing
Non-Operating Humidity	Up to 95% @ 50°C (122°F) non-condensing



ChargePoint, Inc.
240 East Hacienda Avenue
Campbell, CA 95008-6617 USA

Contact Us

Visit [chargepoint.com](https://www.chargepoint.com)

Guillevin: jeff.hoogveld@guillevin.com

ChargePoint, Inc. ("ChargePoint") reserves the right to alter product offerings and specifications at any time without notice. ChargePoint is not responsible, and disclaims any and all liability, for typographical or graphical errors, inaccuracies, or incompleteness that may appear in this document. This document does not expand or otherwise modify ChargePoint's terms and conditions of purchase, including but not limited to the warranty expressed therein.

Copyright © 2022 ChargePoint, Inc. All rights reserved. CHARGEPOINT is a U.S. registered trademark/service mark, and an EU registered logo mark of ChargePoint, Inc. ASSURE and CHARGEPOINT AS A SERVICE are U.S. registered trademarks of ChargePoint Inc. All other products or services mentioned are the trademarks, service marks, registered trademarks or registered service marks of their respective owners. February 2023

ChargePoint CP6000 Series

Networked Charging Station

Installation Guide

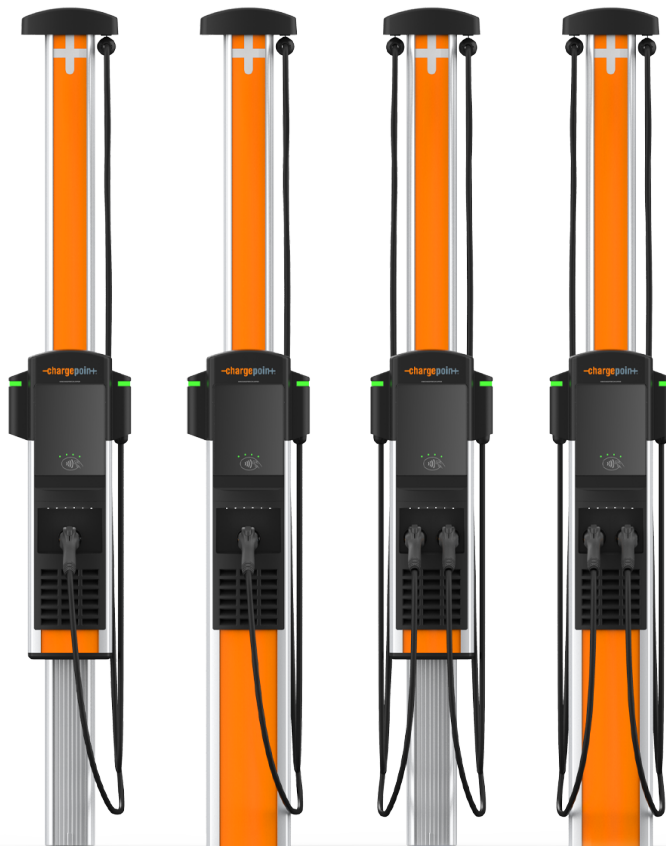

IMPORTANT SAFETY INSTRUCTIONS

SAVE THESE INSTRUCTIONS

WARNING:

1. **Read and follow all warnings and instructions before servicing, installing, or operating the ChargePoint® charging station.** Install and operate only as instructed. Failure to do so may lead to death, injury, or property damage, and will void the Limited Warranty.
2. **Only use licensed professionals to install your ChargePoint charging station and adhere to all national and local building codes and standards.** Before installing the ChargePoint charging station, consult with a licensed contractor, such as a licensed electrician, and use a trained installation expert to ensure compliance with local building and electrical codes and standards, climate conditions, safety standards, and all applicable codes and ordinances. Inspect the charging station for proper installation before use.
3. **Always ground the ChargePoint charging station.** Failure to ground the charging station can lead to risk of electrocution or fire. The charging station must be connected to a grounded, metal, permanent wiring system, or an equipment grounding conductor shall be run with circuit conductors and connected to the equipment grounding terminal or lead on the Electric Vehicle Supply Equipment (EVSE). Connections to the EVSE shall comply with all applicable codes and ordinances.
4. **Install the ChargePoint charging station on a concrete pad using a ChargePoint-approved method.** Failure to install on a surface that can support the full weight of the charging station can result in death, personal injury, or property damage. Inspect the charging station for proper installation before use.
5. **This charging station is not suitable for use in Class 1 hazardous locations, such as near flammable, explosive, or combustible vapors or gases.**
6. **Supervise children near this device.**
7. **Do not put fingers into the electric vehicle connector.**
8. **Do not use this product if any cable is frayed, has broken insulation, or shows any other signs of damage.**
9. **Do not use this product if the enclosure or the electric vehicle connector is broken, cracked, open, or shows any other signs of damage.**
10. **Use only copper conductor wire rated for 90 °C (194 °F).**



IMPORTANT: Under no circumstances will compliance with the information in a ChargePoint guide such as this one relieve the user of the responsibility to comply with all applicable codes and safety standards. This document describes approved procedures. If it is not possible to perform the procedures as indicated, contact ChargePoint. **ChargePoint is not responsible for any damages that may result from custom installations or procedures not described in this document or that fail to adhere to ChargePoint recommendations.**



Product Disposal

Do not dispose of as part of unsorted domestic waste. Inquire with local authorities regarding proper disposal. Product materials are recyclable as marked.

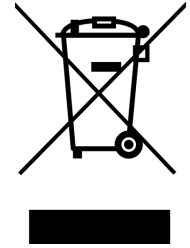

Document Accuracy

The specifications and other information in this document were verified to be accurate and complete at the time of its publication. However, due to ongoing product improvement, this information is subject to change at any time without prior notice. For the latest information, see our documentation online at chargepoint.com/guides.

Copyright and Trademarks

©2013-2023 ChargePoint, Inc. All rights reserved. This material is protected by the copyright laws of the United States and other countries. It may not be modified, reproduced, or distributed without the prior, express written consent of ChargePoint, Inc. CHARGEPOINT is a US, UK, and EU registered trademark and service mark of ChargePoint, Inc. and cannot be used without the prior written consent of ChargePoint.

Symbols

This guide and product use the following symbols:



DANGER: Risk of electric shock



WARNING: Risk of personal harm or death



CAUTION: Risk of equipment or property damage



IMPORTANT: Crucial step for installation success



Read the manual for instructions



Ground/protective earth

Illustrations Used in This Document

The illustrations used in this document are for demonstration purposes only and may not be an exact representation of the product. However, unless otherwise specified, the underlying instructions are accurate for the product.

Contents

- IMPORTANT SAFETY INSTRUCTIONS ii
- 1 Introduction 1**
 - Accessing Complete Documentation 2
 - Power Management 2
 - Site Requirements 2
 - Bring These Tools and Materials 3
 - Inspect the Boxes for Contents 4
- 2 Install a Pedestal Mount 5**
 - Prepare the Pedestal for Mounting 5
 - Mount the Pedestal 7
 - Install the Housing 12
 - Install the CMK 17
- 3 Install a Wall Mount 25**
 - Mount the Brackets 25
 - Mount the CMK 28
 - Prepare the Housing 33
 - Install the Housing 36
 - Install the Conduit 38
- 4 Connect Wiring - North America 39**
 - Grounding Requirements 39
 - Install Circuit Sharing Jumpers 42
 - Install the Power Plate 43
 - Connect the Wiring 44
 - Check Voltages 52
- 5 Assemble the Station 53**
 - Connect the Head Assembly 53
 - Install Cable Clamps 64

6 Complete Station Setup	69
Power Up	69
Configure and Pinpoint the Station	72
Start a Charging Session	75
Questions?	75

Introduction 1

The ChargePoint CP6000 is an all-purpose charging station for property owners, businesses, and municipalities. It can be mounted on a pedestal or a wall.

CP6000 charging stations are alternating current (AC) supply equipment. Once they are installed and activated, they are connected to the AC network.

Note: CP6000 charging stations do not have ventilation capabilities.

IMPORTANT: You must be a licensed electrician and complete online training to become a ChargePoint certified installer. If you do not complete training, you cannot access the ChargePoint network to complete installation.



Find online training at: chargepoint.com/installers

If the charging station is not installed by a ChargePoint certified installer, using a ChargePoint approved method, it is not covered under warranty and ChargePoint is not responsible for any malfunctions.

Note: CP6000 charging stations are available in several configurations. The images in this guide might not match your station exactly; however, the installation steps are the same unless otherwise noted.

Accessing Complete Documentation

Access ChargePoint documents at chargepoint.com/guides.

Document	Content	Primary Audiences
Datasheet	Full station specifications	Site designer, installer, and station owner
Site Design Guide	Civil, mechanical, and electrical guidelines to scope and construct the site	Site designer or engineer of record
Concrete Mounting Template Guide	Instructions to embed the charging station template in a concrete pad with anchor bolts and conduit placement	Site construction contractor
Construction Signoff Form	Checklists used by contractors to ensure the site is correctly completed and ready for product installation	Site construction contractor
Installation Guide	Anchoring, wiring, and powering on	Installer
Operation and Maintenance Guide	Operation and preventive maintenance information	Station owner, facility manager, and technician
Service Guide	Component replacement procedures, including optional components	Service technician
Declaration of Conformity	Statement of conformity with directives	Purchasers and public

Power Management

Using ChargePoint Power Management technology, sites can install more stations than would otherwise be supported by the available electrical service. A maximum aggregate load is defined for a group of charging stations. ChargePoint cloud-based services manage the individual power output of each station (or port) to ensure the maximum load is never exceeded.

A CP6000 charging station provides up to 80 A of output current to each charging port.

Site Requirements

Ensure that the appropriate wiring, circuit protection, and metering are in place at the installation location by reviewing the Site Design Guide and the Datasheet, as well as the wiring diagrams and grounding requirements in the Connect Wiring chapter.



IMPORTANT: Ensure the installation complies with all applicable codes and ordinances.

Bring These Tools and Materials

To install CP6000 charging stations, you need the following tools:



L wrench - Torx end (T25)
included, combined with 4 mm hex



L wrench - Hex end (4 mm)
included, combined with T25 Torx



Mini-ratchet wrench



Torx screwdriver (T25)



Adjustable torque wrench
nut size 4 mm and 24 mm



8 mm hex wrench



Wire stripper



Level



Multimeter
(solenoid type voltmeter preferred)



Diagonal wire cutter



CMK ball removal (included)



#3 Philips screwdriver



Drill and tap for appropriate wall
attachment hardware
(wall mount stations only)



10 mm socket



Protective cut-proof gloves

Wall mounting hardware requirements vary based on surfaces:

- Masonry anchors rated for at least 318 kg (700 lb) of pull-out force.
- Attachment hardware appropriate for mounting surface. For example, use 10 x 75 mm (3/8 x 3 in) lag bolts if mounting on a wooden wall.

Inspect the Boxes for Contents

The CP6000 ships in multiple boxes. Check to make sure you have all of the following parts before beginning work.

- a. Cable Management Kit (CMK)
- b. Top cap
- c. Pedestal or wall mount enclosure
- d. Head unit assembly
- e. Smart EV cables
- f. Mounting adapter (only wall mount stations)
- g. Circuit share jumper kit
- h. Quick Reference Guide, rating labels

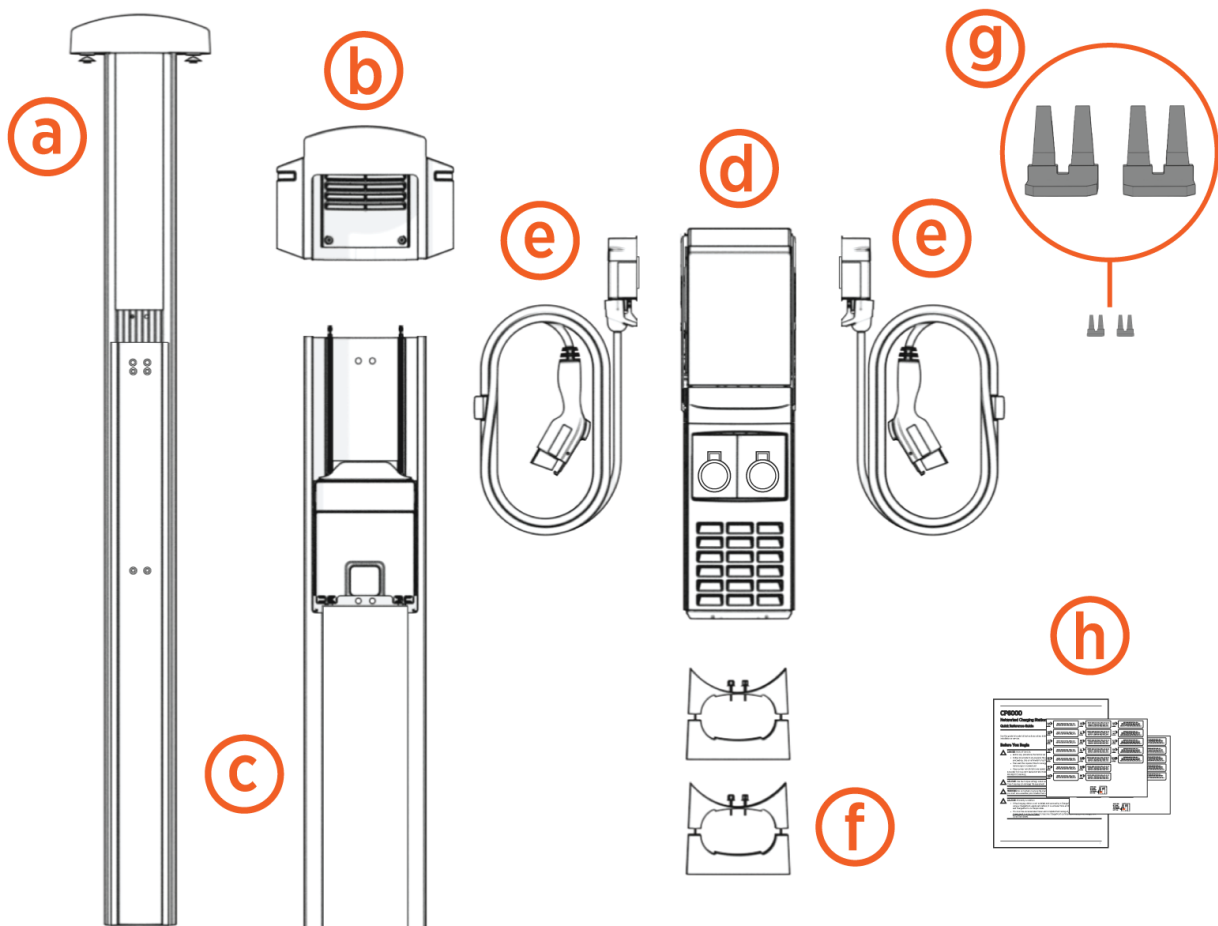

IMPORTANT:



If a single supply circuit is feeding a dual port station, you **MUST** install power management jumpers for both ports to operate correctly. Contact ChargePoint Support to order power management jumpers if required.

Install a Pedestal Mount 2

Prepare the Pedestal for Mounting

1. Lift the power plate cover. Loosen, but do not remove, two screws.

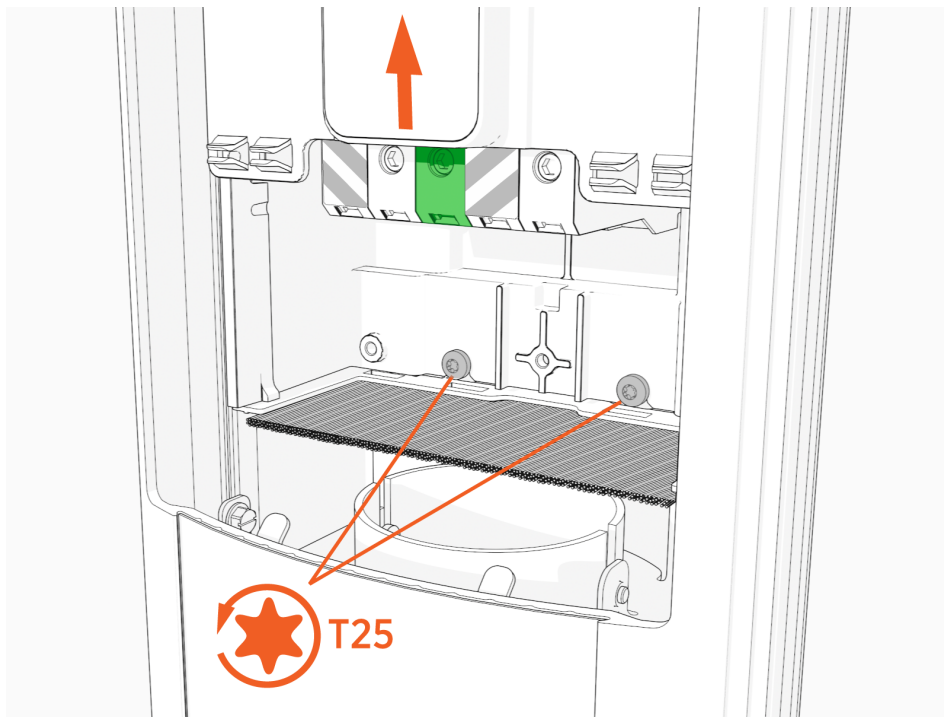

-
2. Remove the power plate and set it gently on a padded surface.

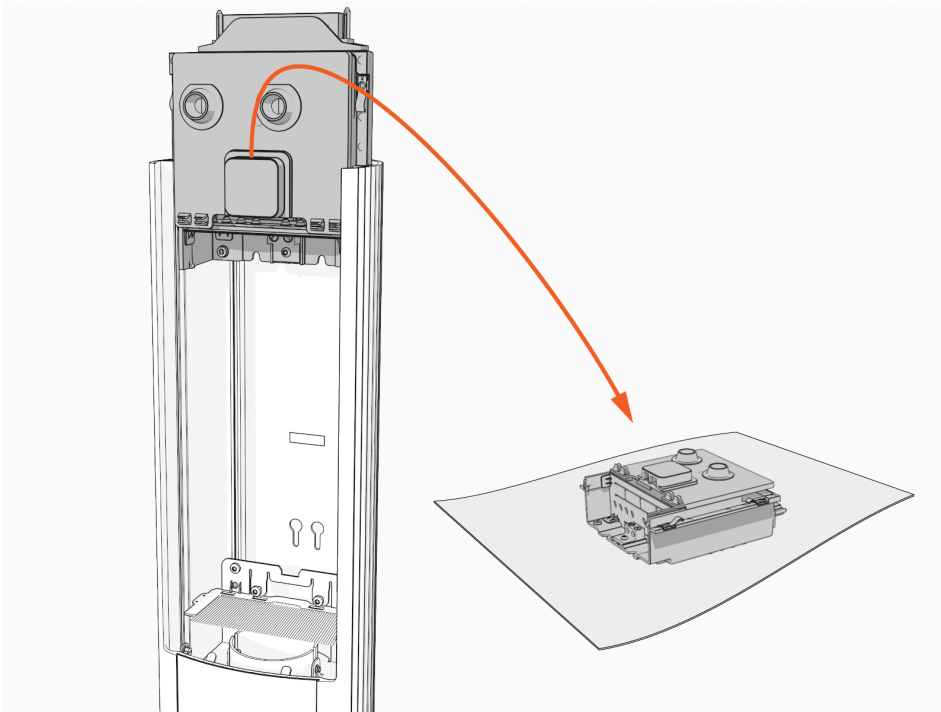

3. Use the L-wrench or mini-ratchet wrench to loosen, but not remove, two screws.

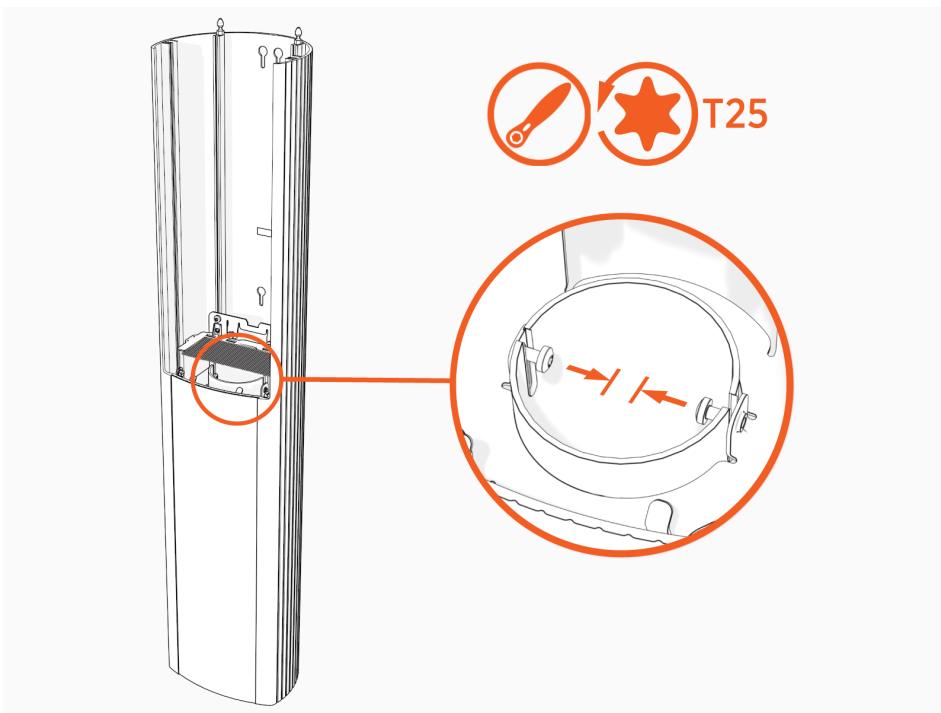

4. Remove the housing (a) from the pedestal (b). Keep the rubber spacer (c) in place.

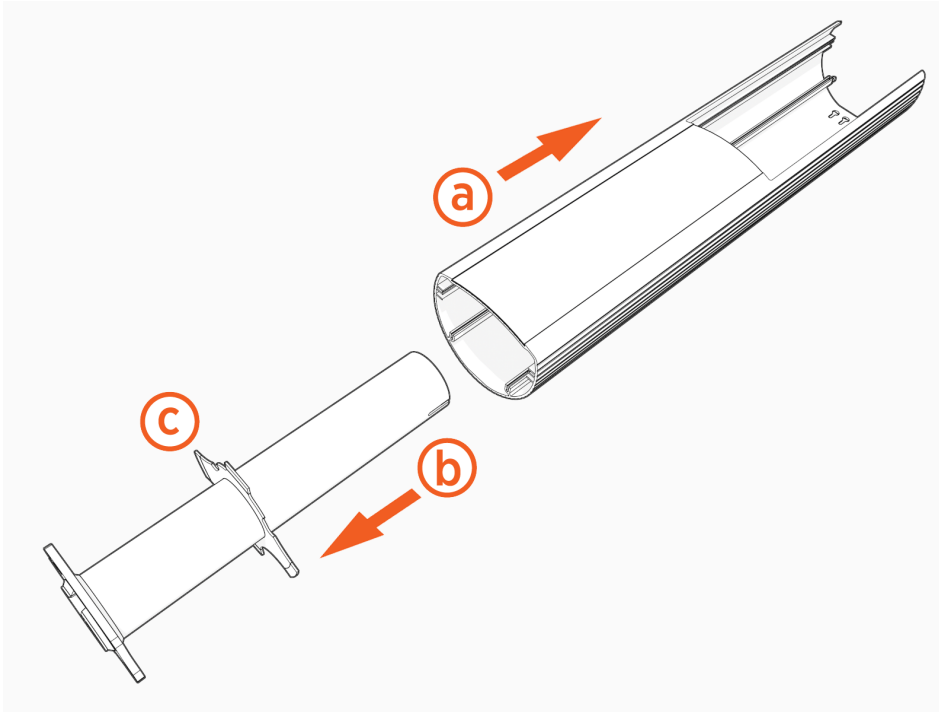

Mount the Pedestal

1. Confirm that the location has been prepared according to the Site Design Guide and the Concrete Mount Template by visiting [chargepoint.com/guides](https://www.chargepoint.com/guides).

2. You should see the following:

- a. Concrete mounting template
- b. Three bolts set into concrete
- c. Two nuts and three washers on each bolt
- d. Template front
- e. Bolts extending 60 mm (2 1/3 in) to 100 mm (4 in)
- f. Conduit stub-up measuring 152 mm (6 in) to 590 mm (2 ft)
- g. Approximately 1.5 m (5 ft) of service wiring
- h. CPF50 adapter cover (only if replacing CPF50)

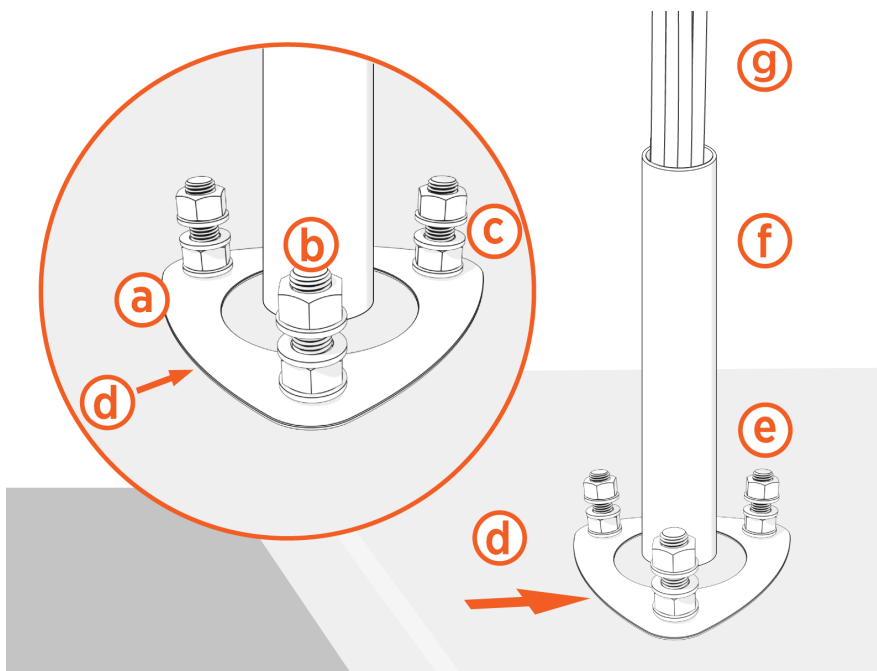

3. Remove top nuts and washers.

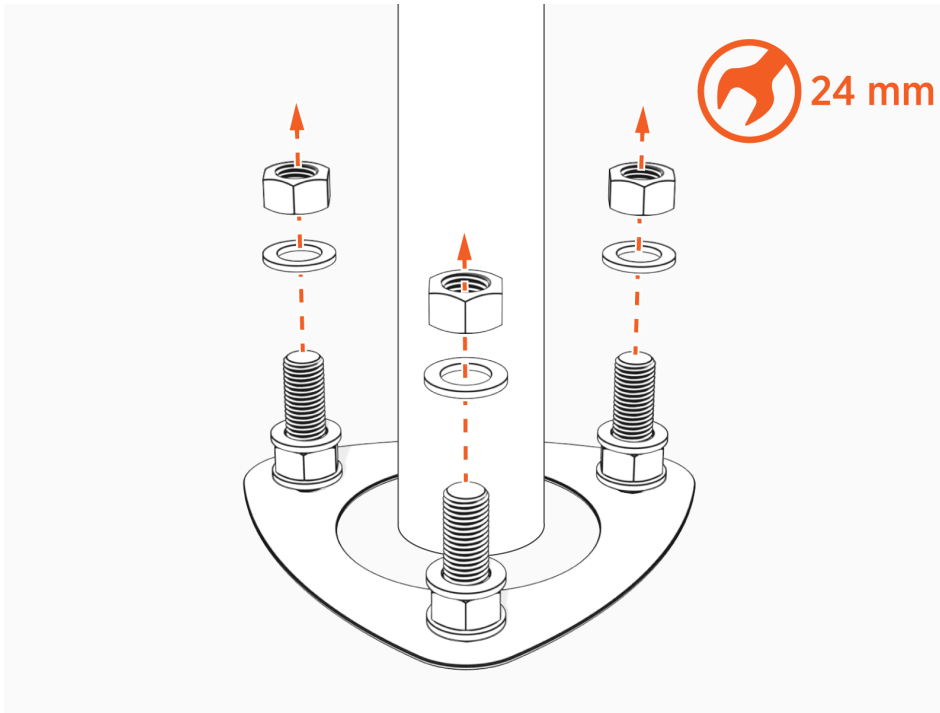

4. Adjust the lower nuts as necessary to be level.

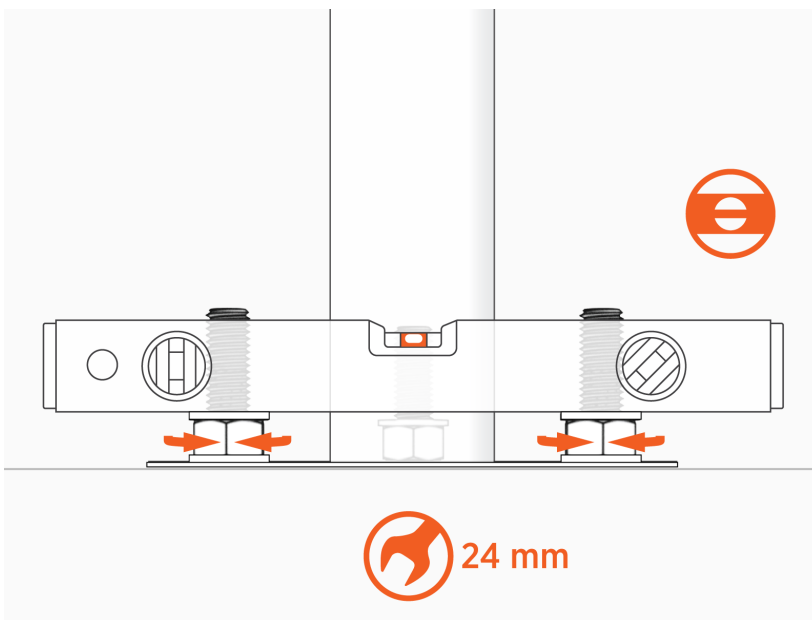

-
5. Place the pedestal over the conduit and route the wiring through the pedestal.



IMPORTANT: Avoid damaging the conduit.

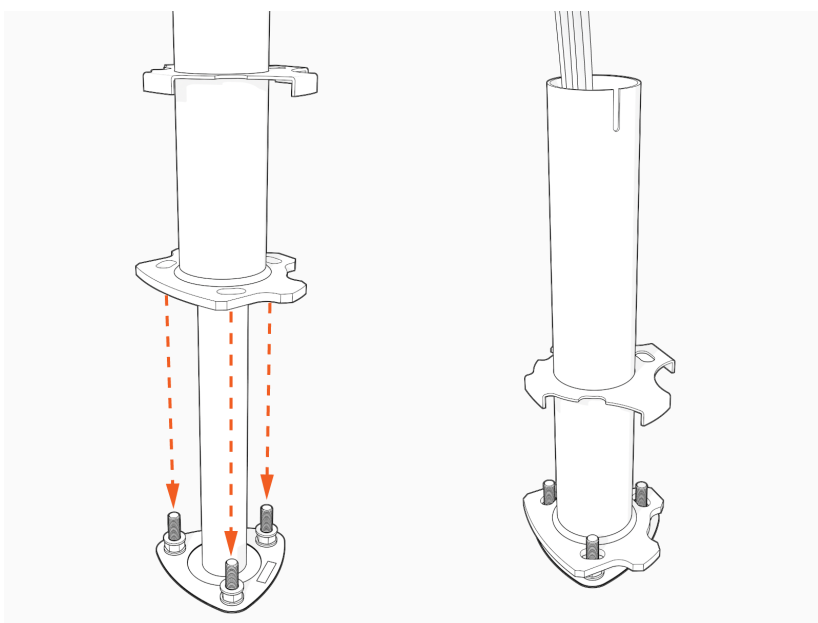

IMPORTANT: Ensure the pedestal is facing the parking space.

6. Fasten the pedestal to the bolts and hand tighten.

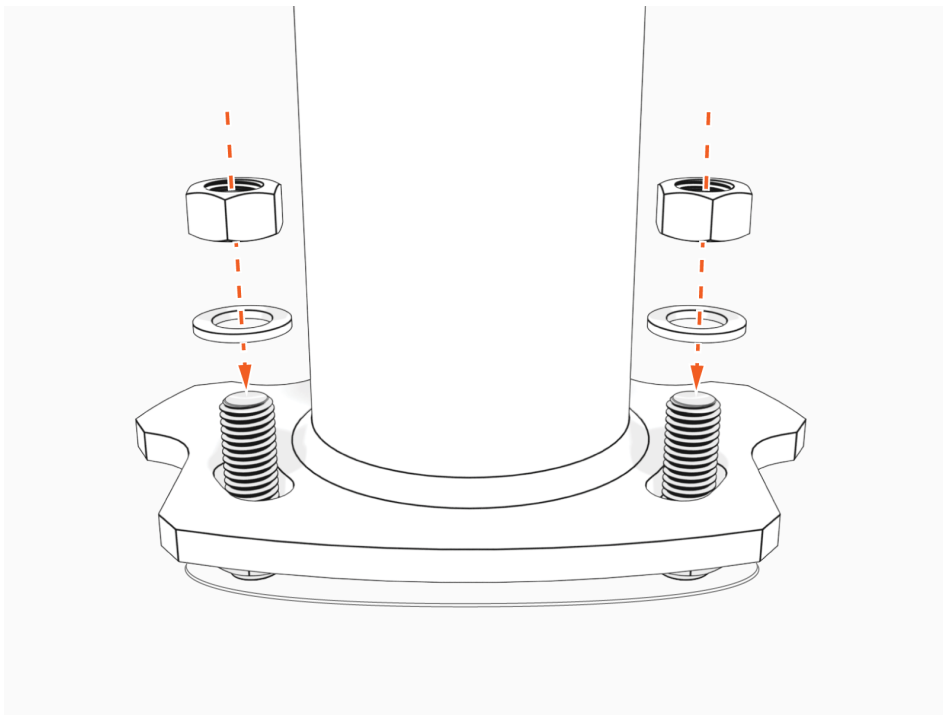

7. Ensure pedestal is level and plumb.

Verify accuracy after each adjustment by positioning the level at various locations on the pedestal, above each bolt.

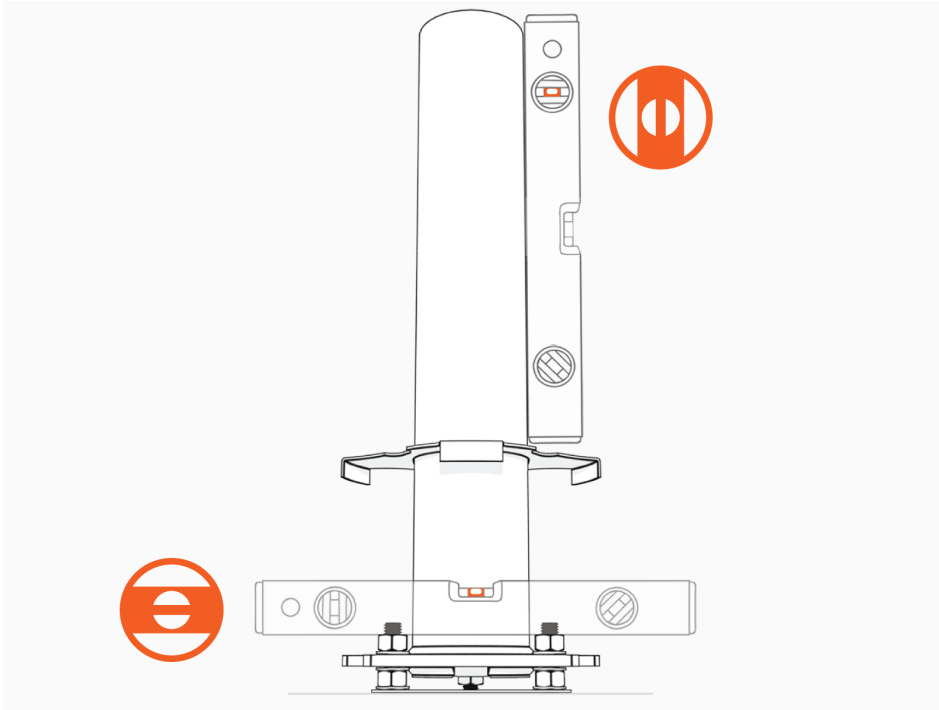

8. Torque the top nuts to 120 Nm (88 ft-lb).

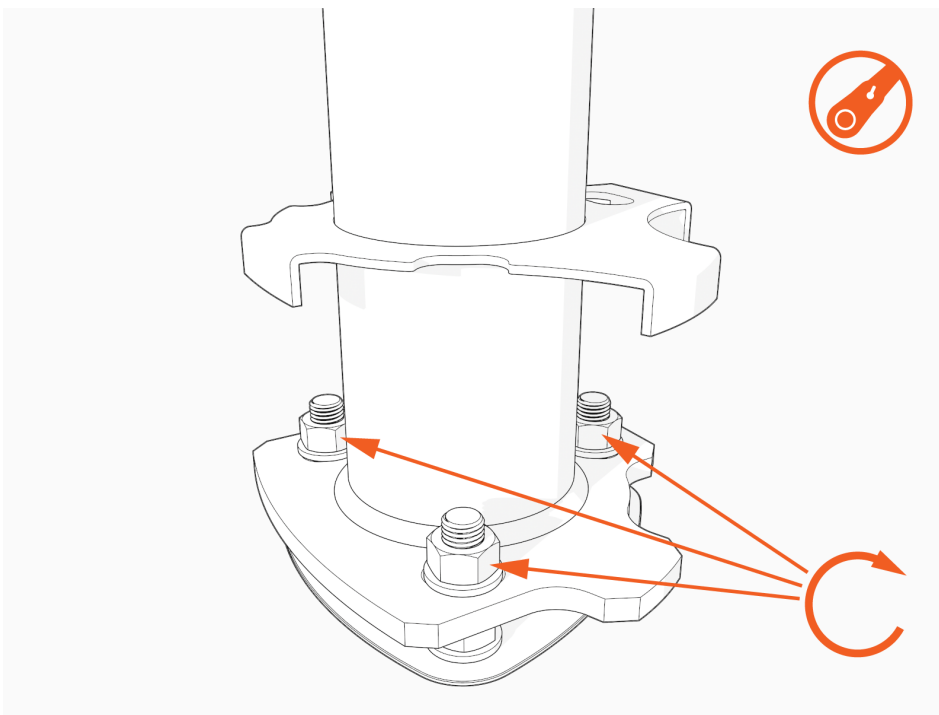

Install the Housing

- 1. Align and slide the rubber spacer down.

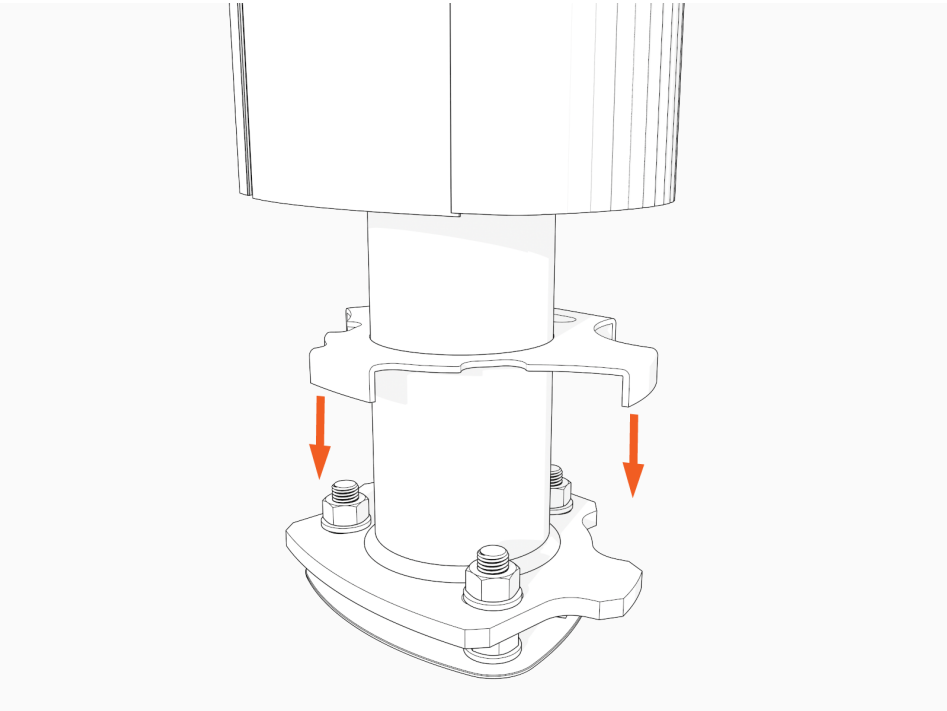

- 2. Optional: If replacing a CPF50, tuck the edges of the rubber spacer below the black plastic cover.

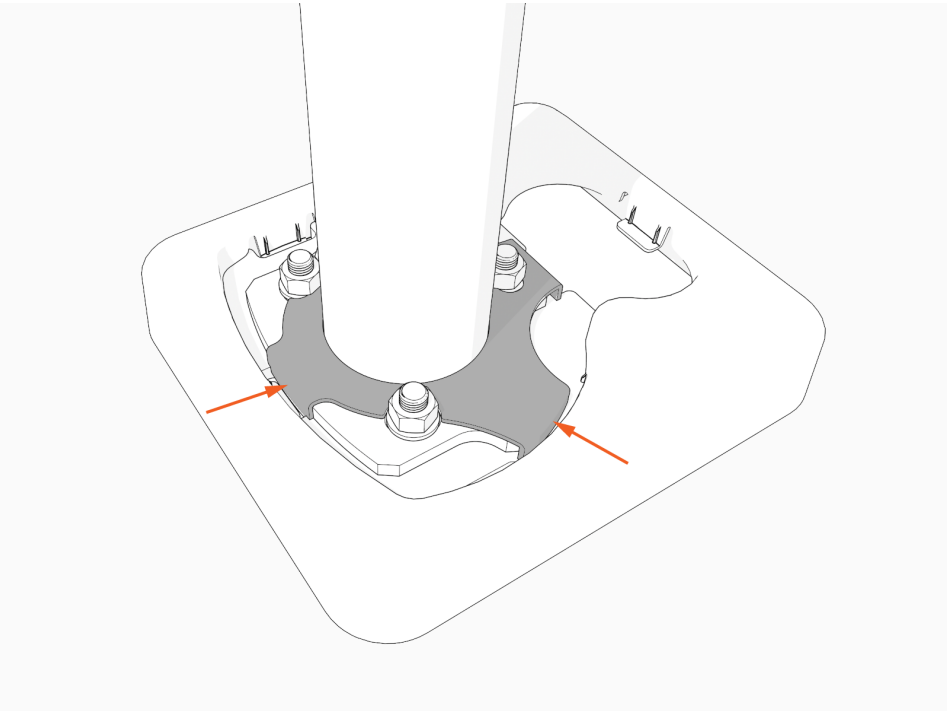

3. Slide the housing down.

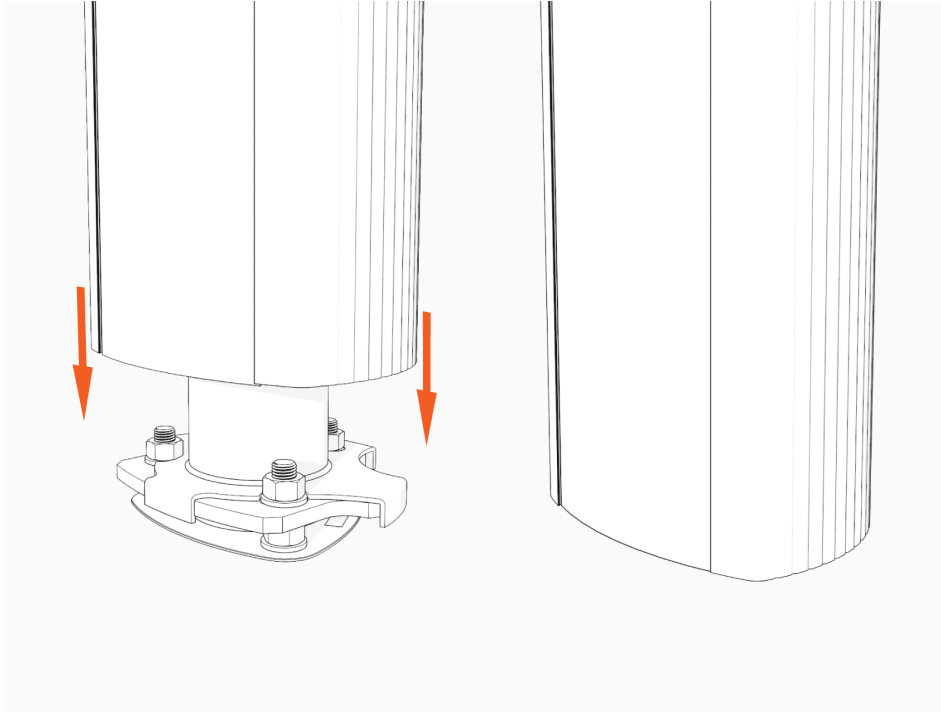

4. Align the screws.

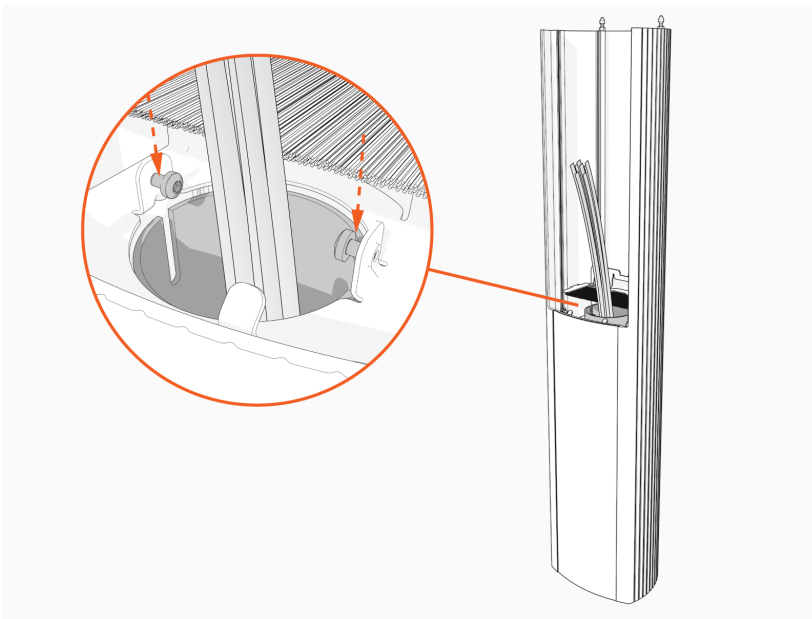

- Firmly align pedestal to the bottom surface.

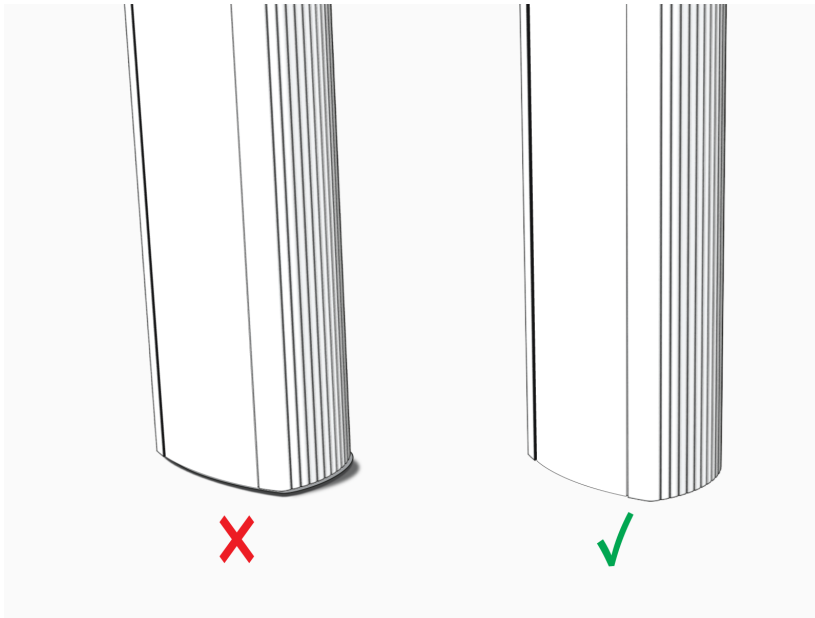

IMPORTANT: Do not seal the pedestal to the concrete pad with caulking, silicone, or other sealing material. The pedestal is designed to shed moisture between its bottom surface and the concrete pad. Sealing the pedestal to the concrete can trap water inside the housing.

- Use the L-wrench or mini-ratchet wrench to torque screws to 4.6 Nm (40 in-lb).

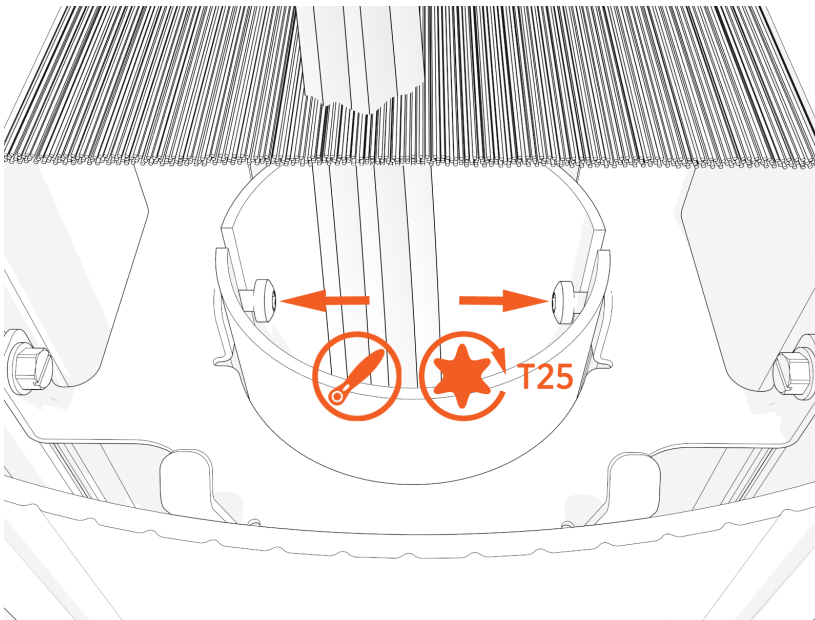

Alternative Installation: Side Mounted Conduit

If the conduit cannot come from below the pedestal (existing concrete in a parking garage, for example), mount the pedestal and ensure it is level and tight, then follow these steps.

You need a hole saw or a knockout punch.

1. Mark the conduit entry point on either side of the housing. The center of the opening must be 635 mm (25 in) from the bottom and 100 mm (4 in) from the front, a location that does not intersect any internal ribs.

Drill or punch a hole for a 32 mm (1.25 in) trade size knockout.

Note: Images are not to scale. Measurements appear in metric units (mm), followed by imperial equivalents (inches).

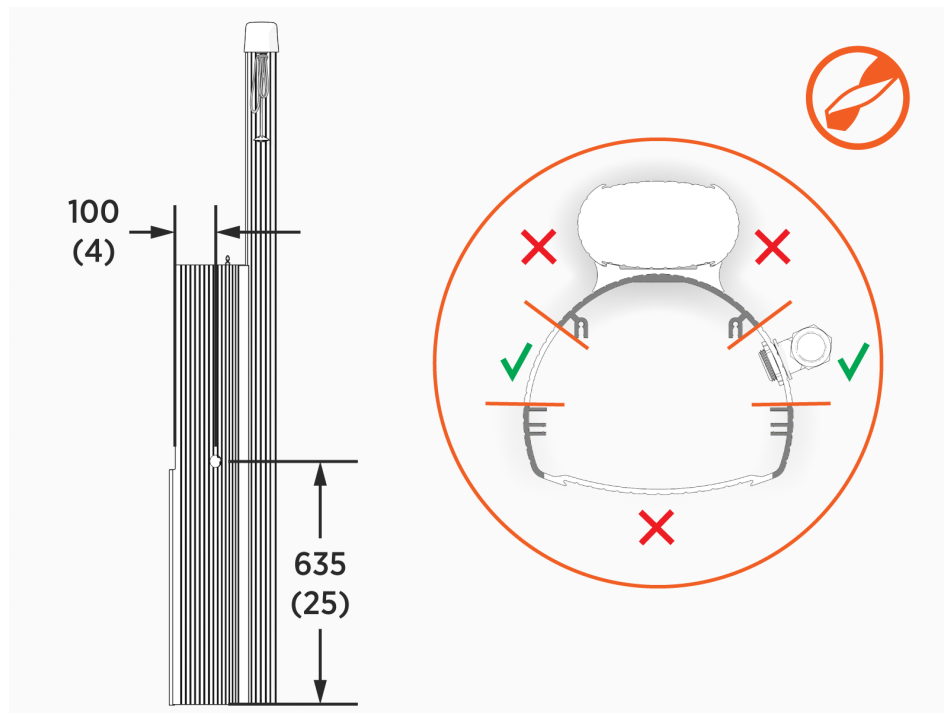

-
2. Pull wire through the conduit, protecting the wires from sharp edges of the internal structural components.

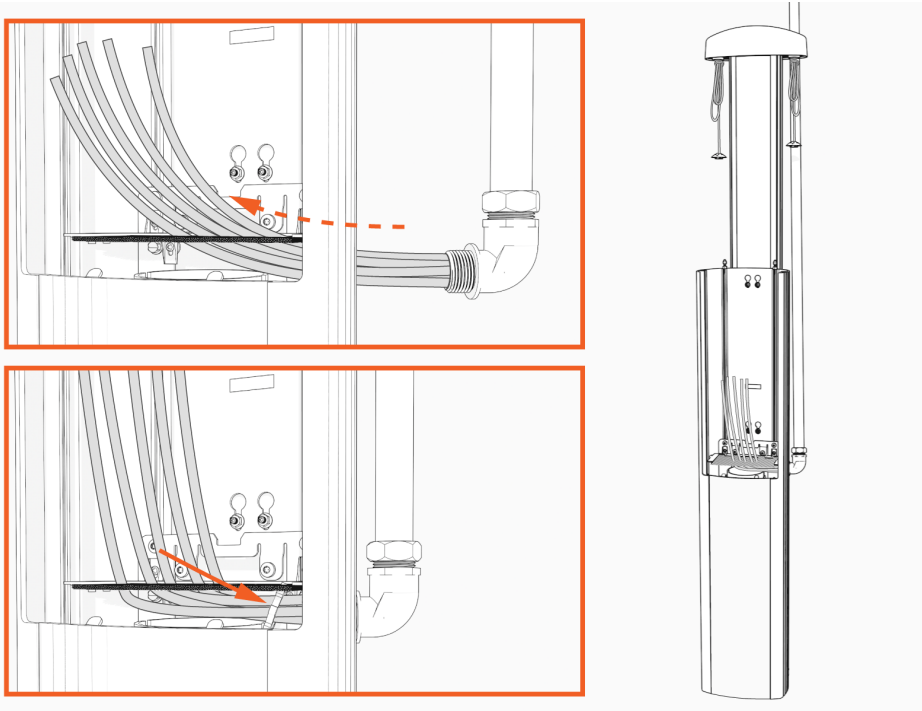

3. Seal the conduit entry into the pedestal housing using an approved sealing method.



IMPORTANT: Ensure the installation complies with all applicable codes and ordinances.

Install the CMK

1. Remove the two stickers covering the holes on the back of the pedestal housing.

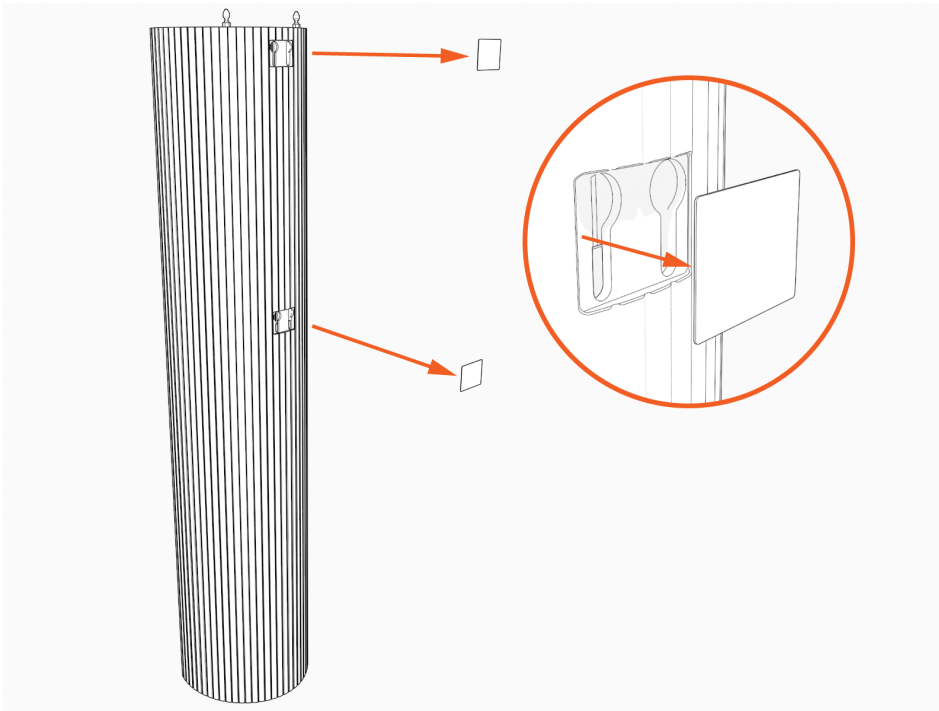

2. Position the Cable Management Kit (CMK) packaging near the base of the pedestal.

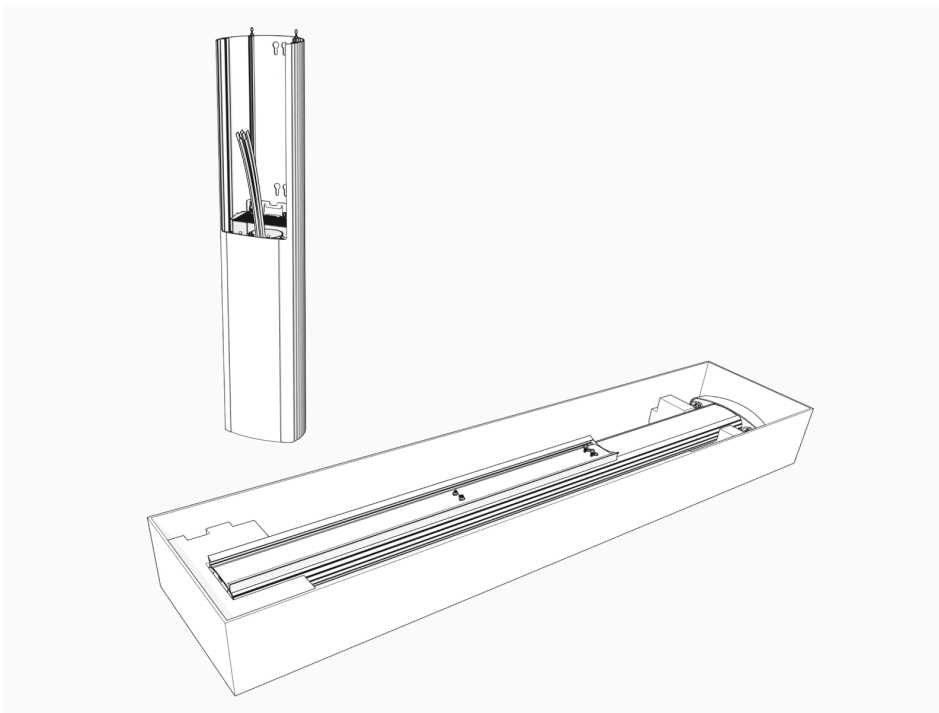

-
3. If you do not see a knot tied near the top of the cable clamp rope, pull the rope out about 600 mm (2ft) and tie a slip knot near the top of the CMK.

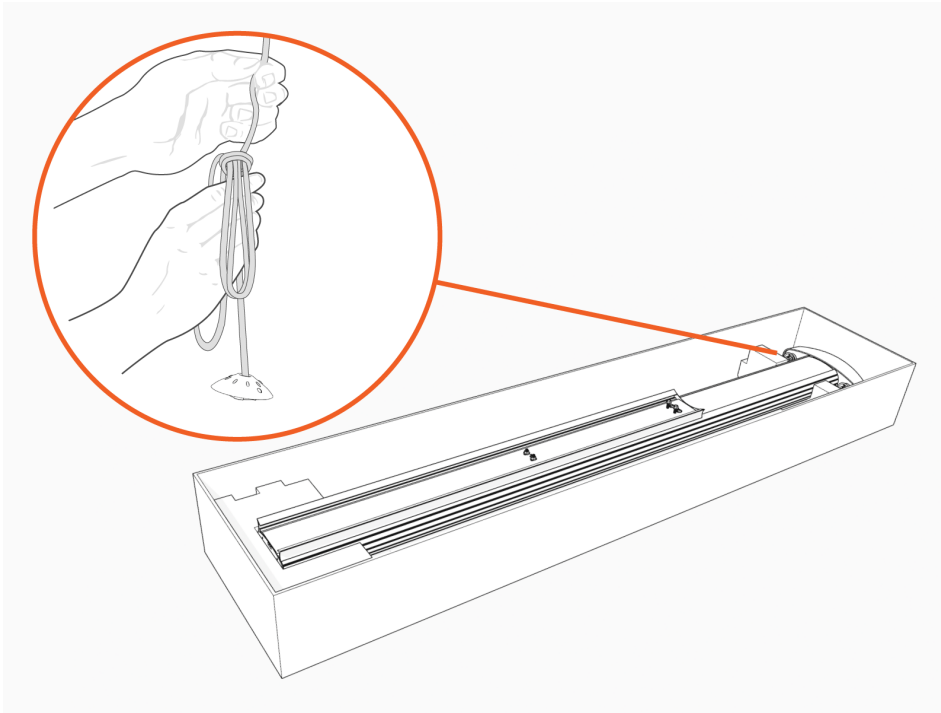

4. Remove and discard the shipping screws.

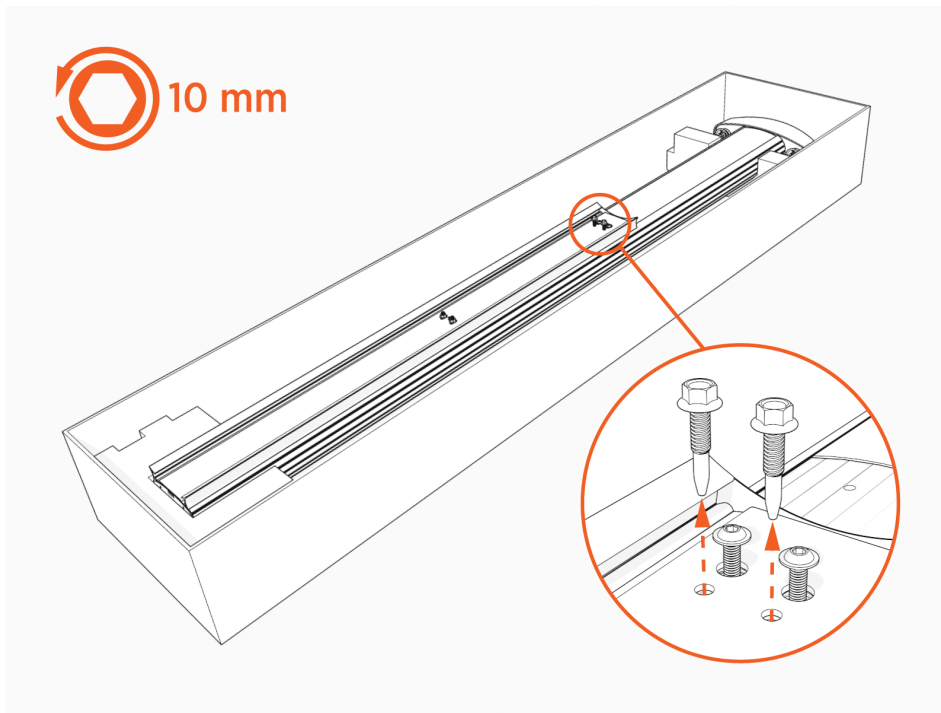

WARNING: When you remove the shipping screws, the counterweights are free to move in either direction. To prevent damage or injury, always carry the assembly with the top end higher than the bottom end.

-
5. Stand the CMK upright slowly. The counterweights will drop.

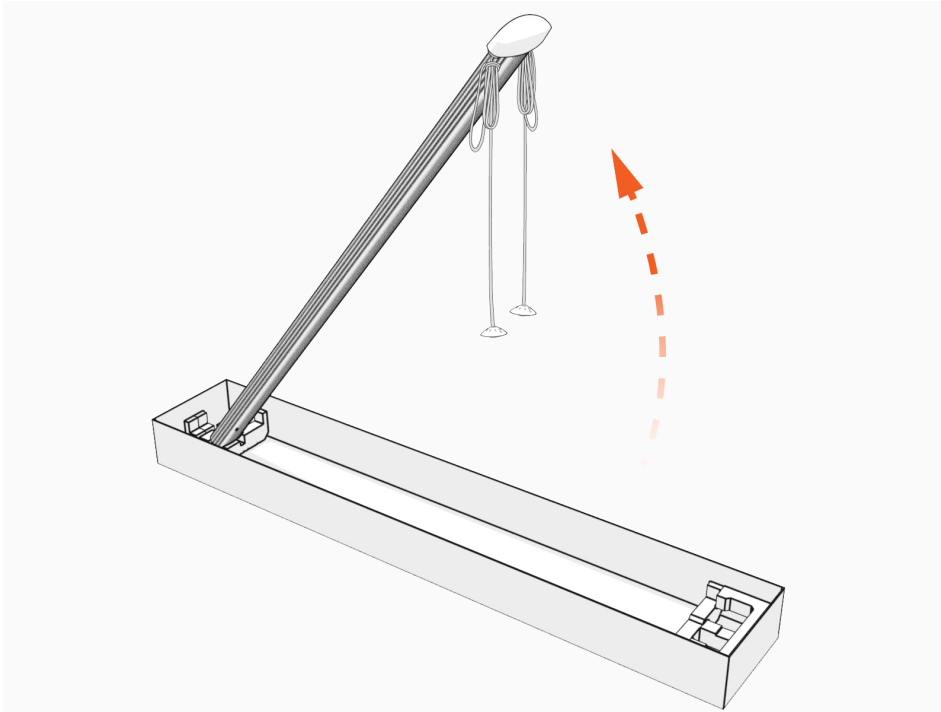

6. Place the CMK behind the pedestal housing and align the mounting screws (top) and nuts (bottom). Lower the CMK.

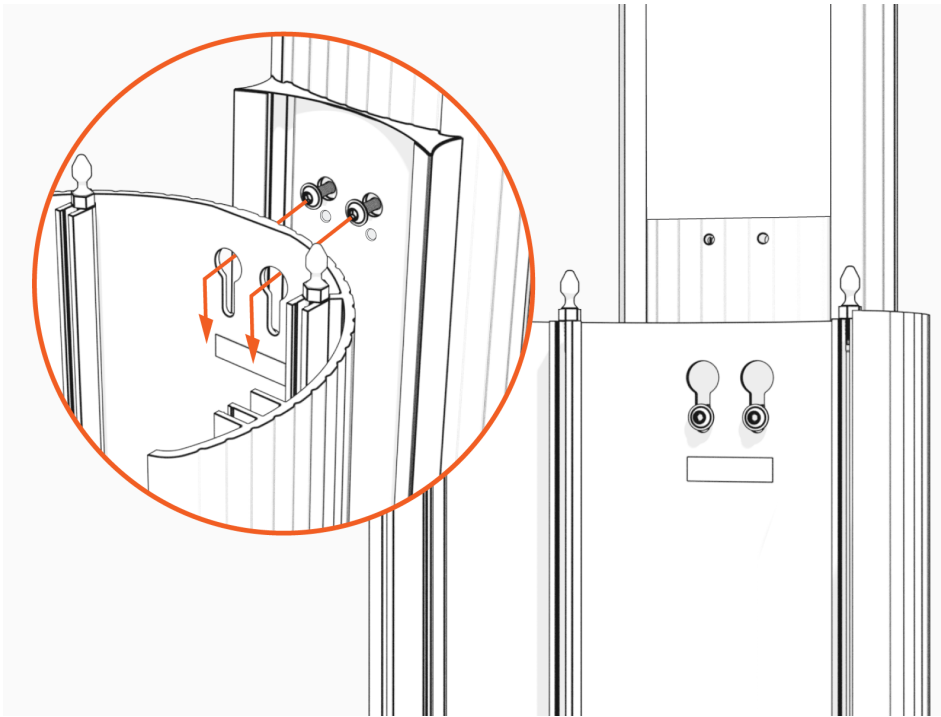



IMPORTANT: Make sure there is no gap between the spacer and the pedestal housing.

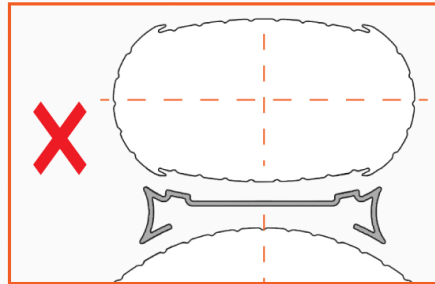
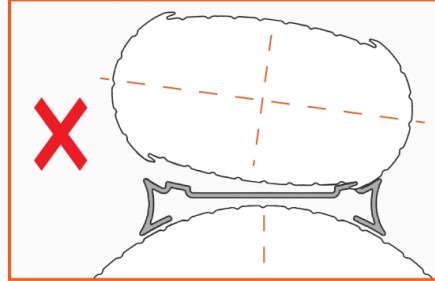
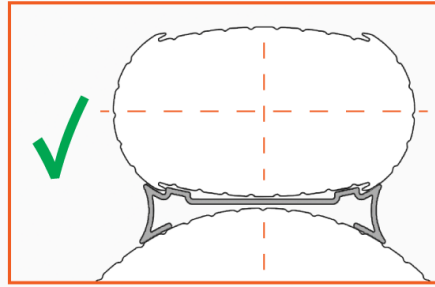
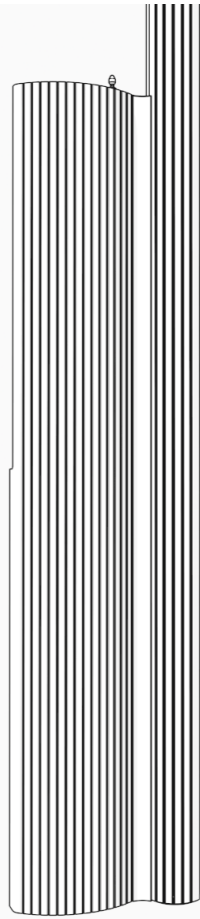

7. Torque the top T25 screws to 5.7 Nm (50 in-lb). Use a 10 mm wrench to tighten the nuts near the bottom to 5.7 Nm (50 in-lb).

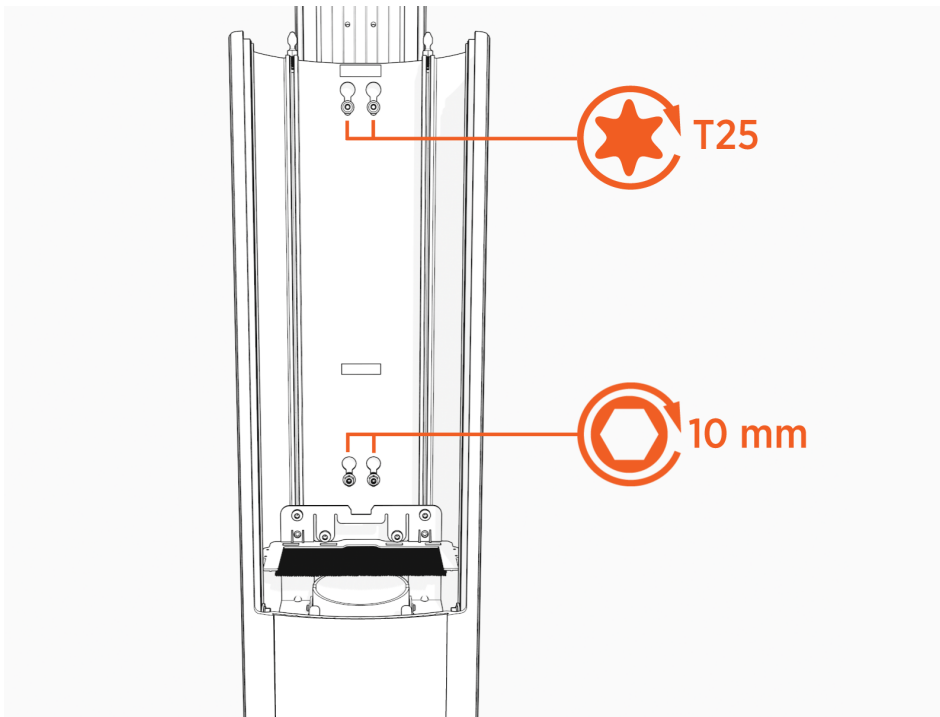

After installing the pedestal mount, go to [Connect Wiring - North America](#).

Install a Wall Mount 3

Mount the Brackets

1. Mark holes and ensure they are level.

Note: Images are not to scale. Measurements appear in metric units (mm), followed by imperial equivalents (inches).

- a. Wall mount brackets
- b. Ground level

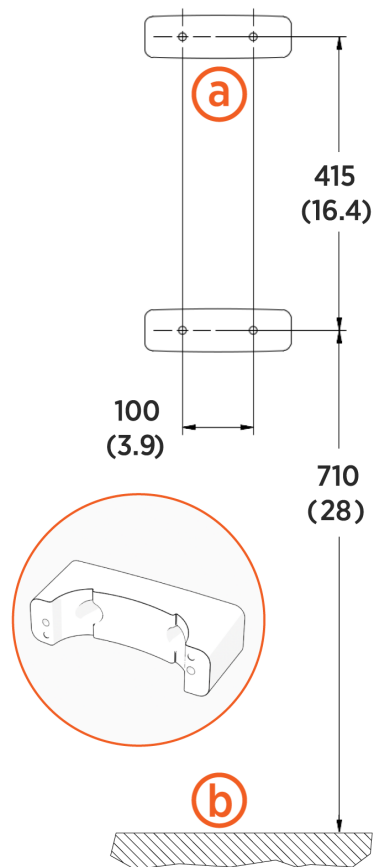

2. Use a drill and bit appropriate for the type of wall to drill four holes.

3. For masonry or concrete walls, insert masonry anchors (not included) rated for at least 318 kg (700 lb) of pull-out force.

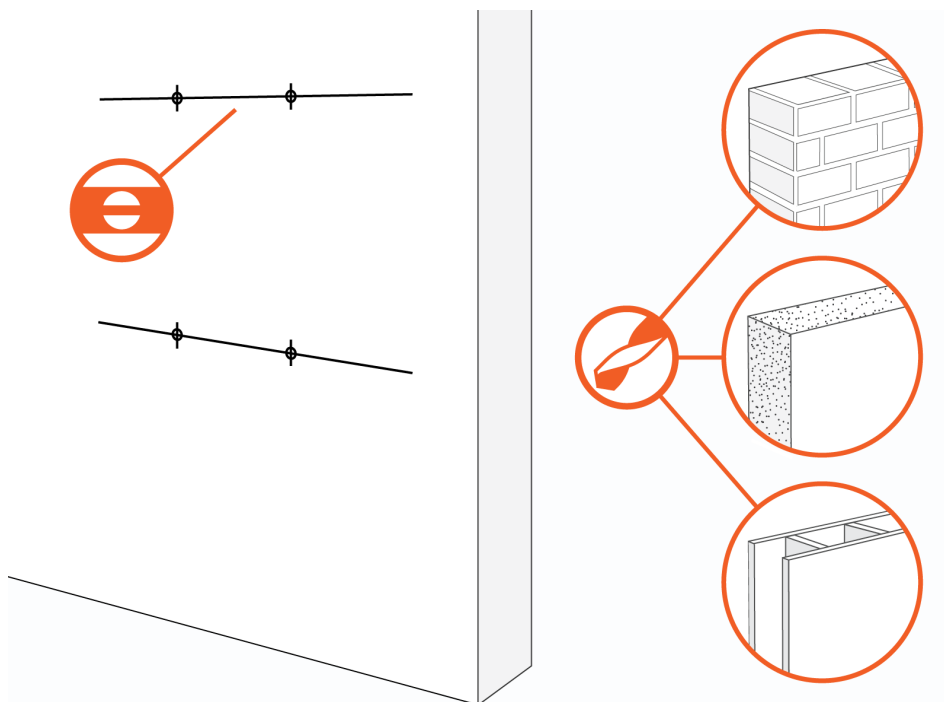

Hollow wall	<ul style="list-style-type: none"> • Bridge two studs with channel strut
Wood studs	<ul style="list-style-type: none"> • 10 mm (3/8 in) lag bolts; at least 64 mm (2 1/2 in) long • 10 mm (3/8 in) washers, • Appropriate channel strut nuts
Masonry wall	<ul style="list-style-type: none"> • 10 mm (3/8 in) expanding masonry fasteners
Wood wall	<ul style="list-style-type: none"> • 10 mm (3/8 in) x 75 mm (3 in) lag bolts

4. Mount brackets and ensure they are level.

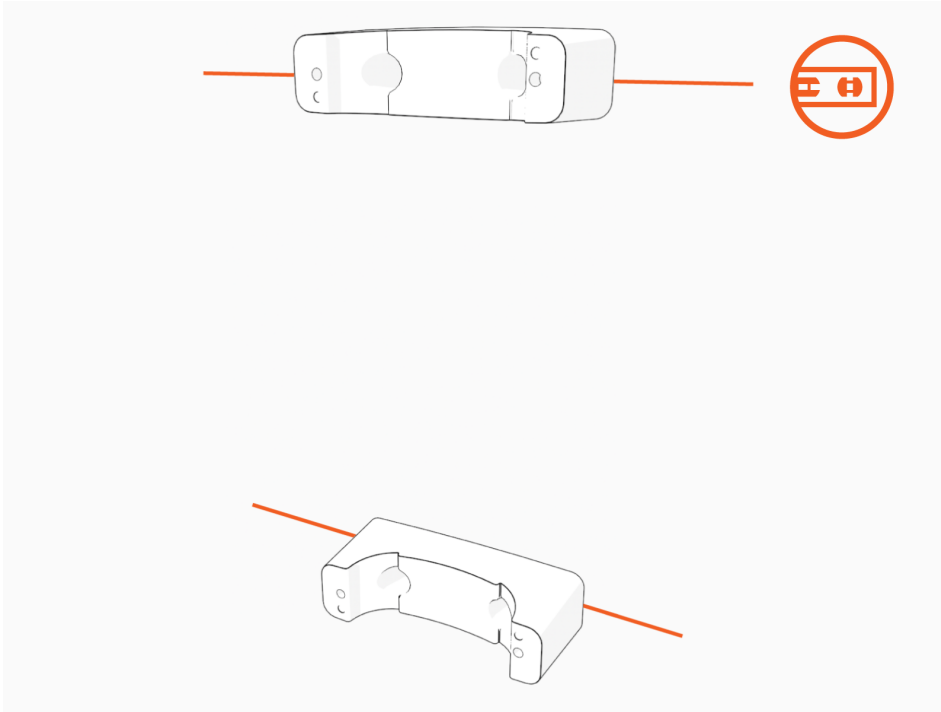

Mount the CMK

- 1. Position the Cable Management Kit (CMK) packaging near the wall. Place the front brackets within reach.

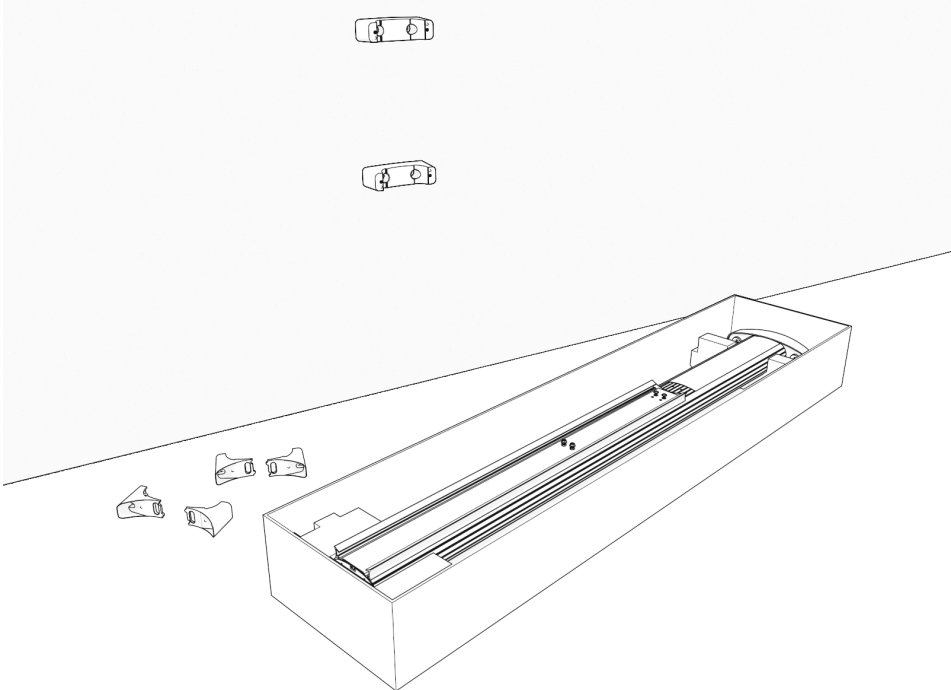

2. If you do not see a knot tied near the top of the cable clamp rope, pull the rope out about 600 mm (2ft) and tie a slip knot near the top of the CMK.

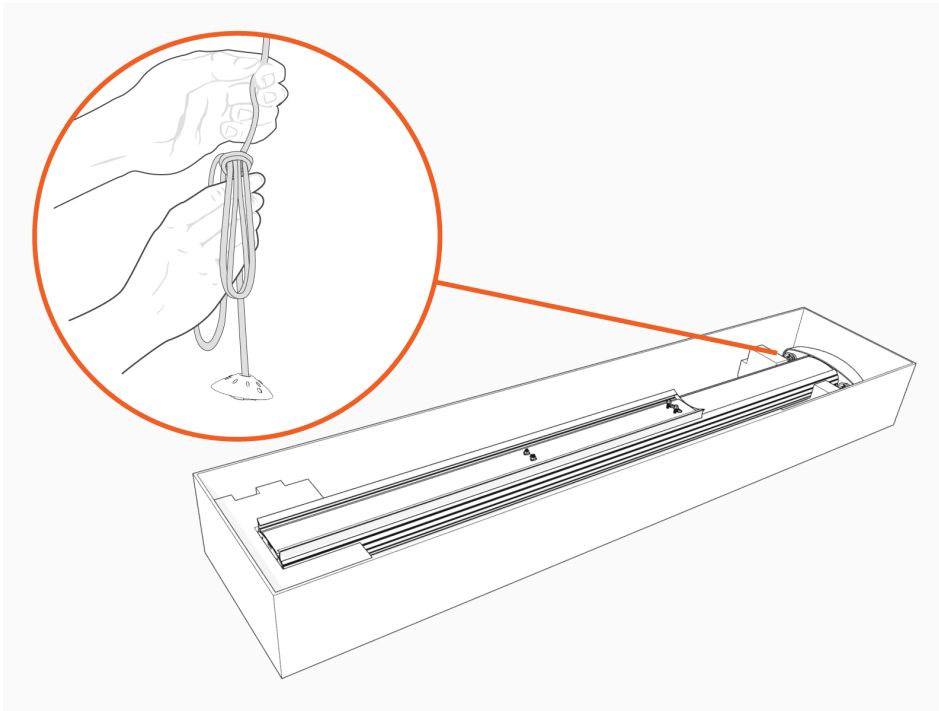

-
3. Remove and discard the shipping screws.

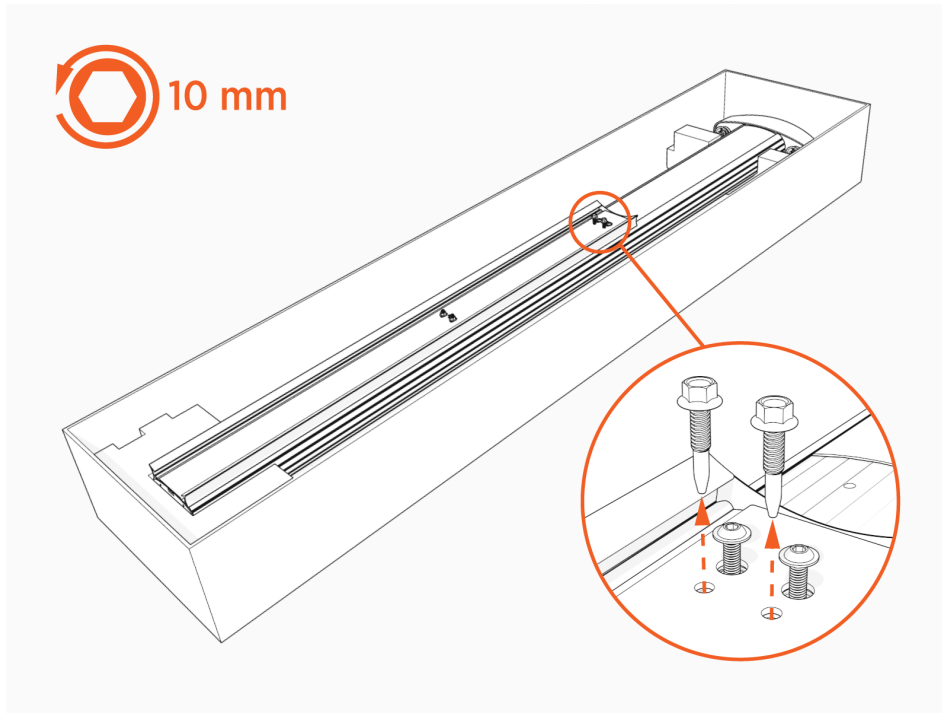

WARNING: When you remove the shipping screws, the counterweights are free to move in either direction. To prevent damage or injury, always carry the assembly with the top end higher than the bottom end.

4. Remove the spacer.

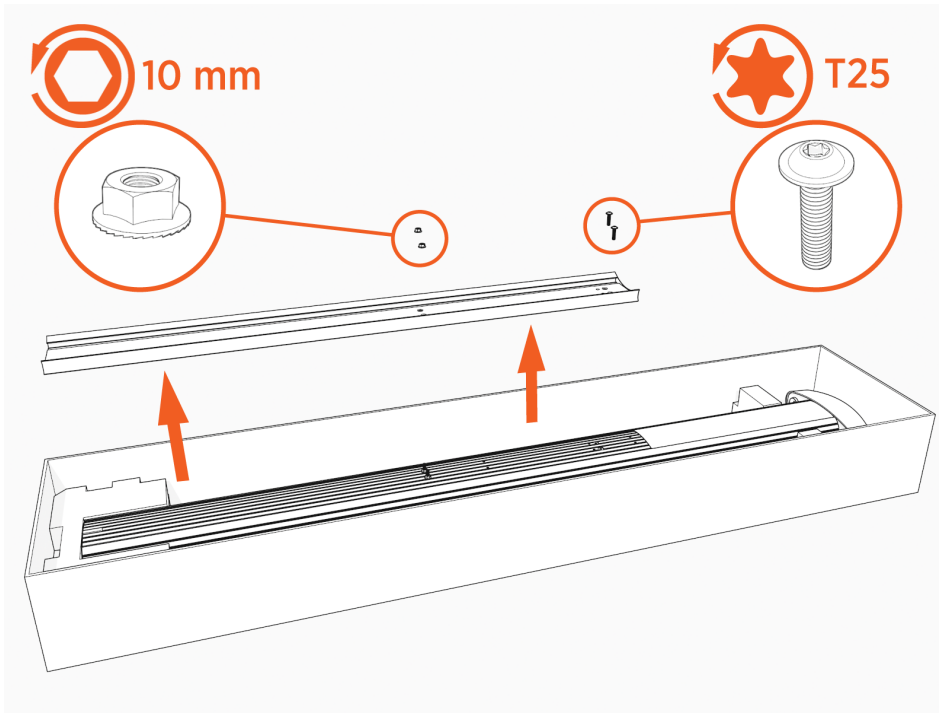

5. Stand the CMK upright slowly. The counterweights will drop.

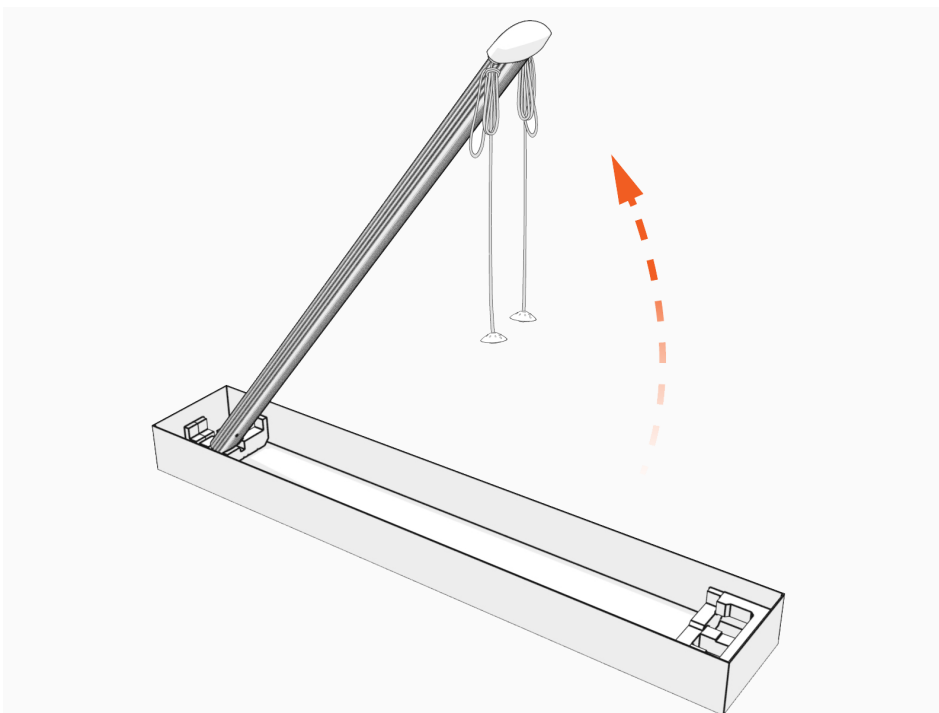

-
6. Tilt the CMK up against the rear brackets, rest the bottom on the ground and steady with one hand while using the other to position the top front bracket.

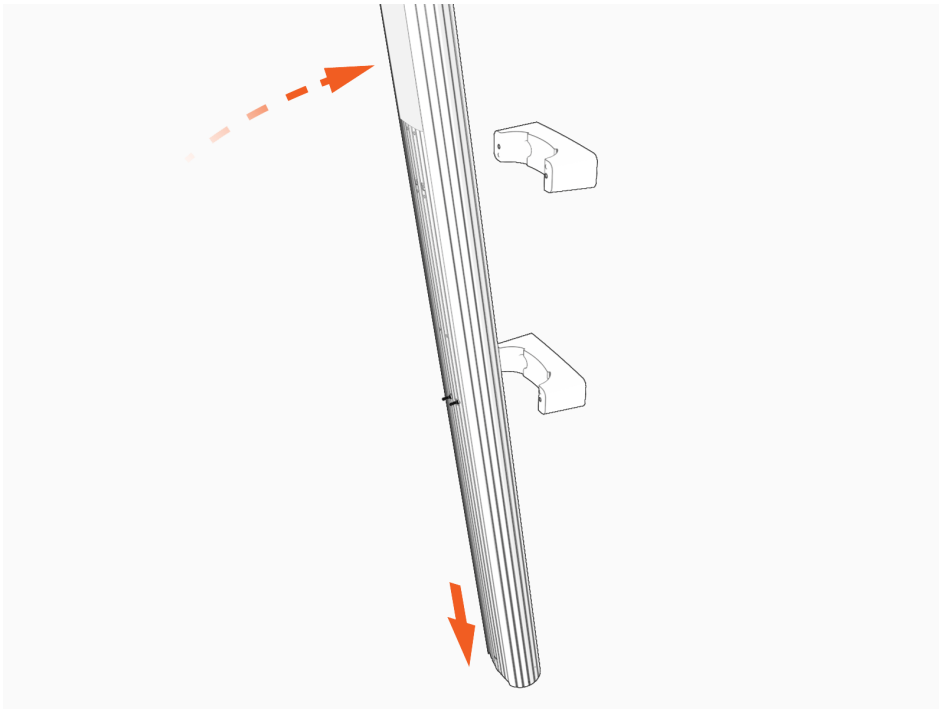

7. Align both sets of brackets. Insert the M6 x 20 mm screws and torque to 7 Nm (5 ft-lb).

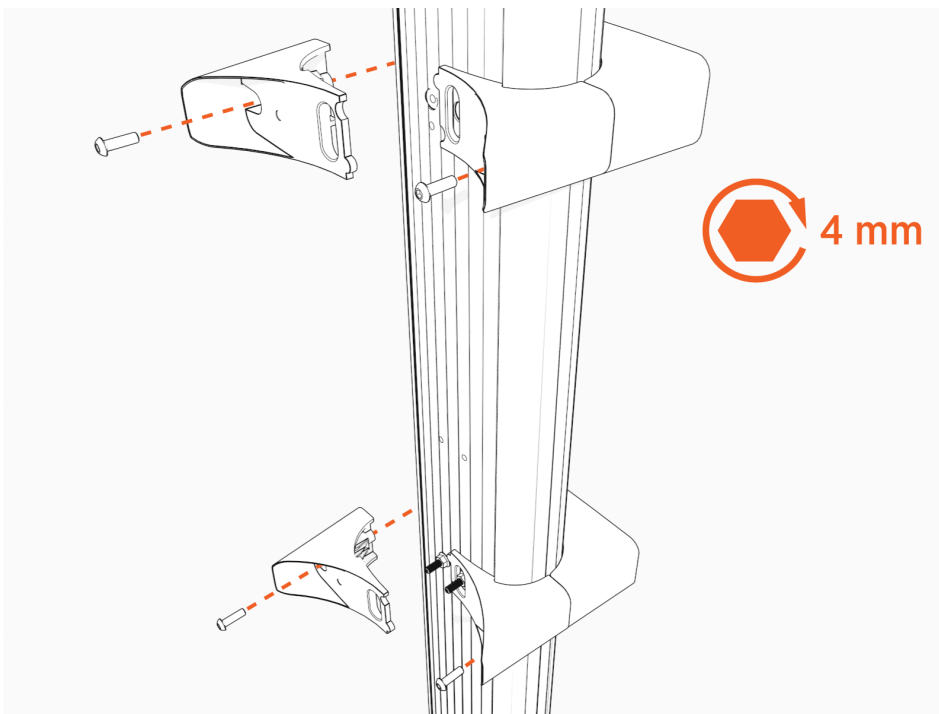

Prepare the Housing

1. Lift the power plate cover. Loosen, but do not remove, two screws.

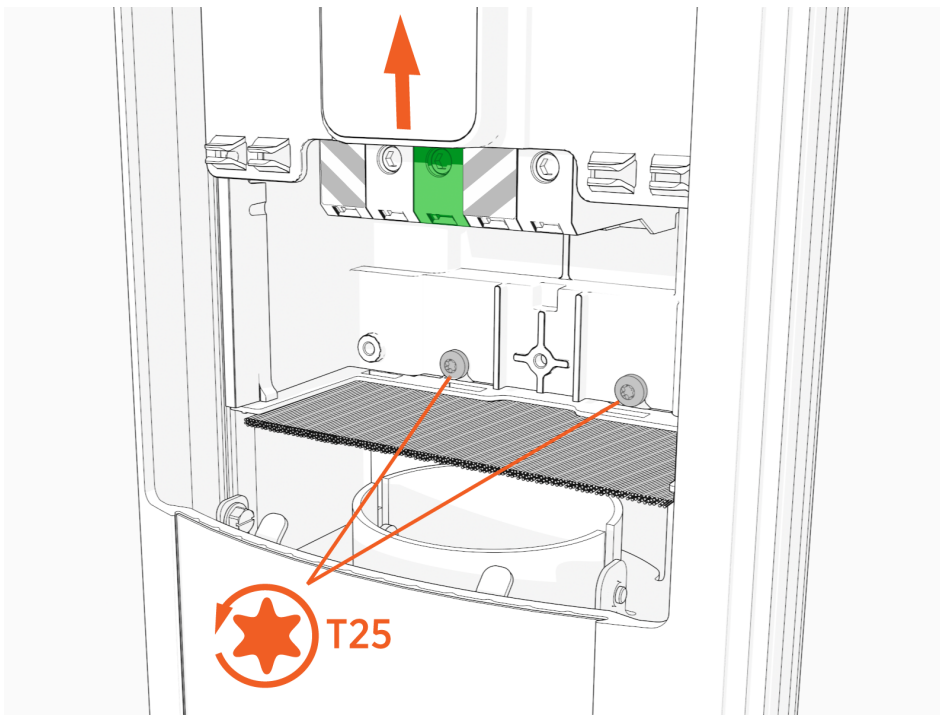

2. Move the power plate and set it gently on a padded surface.

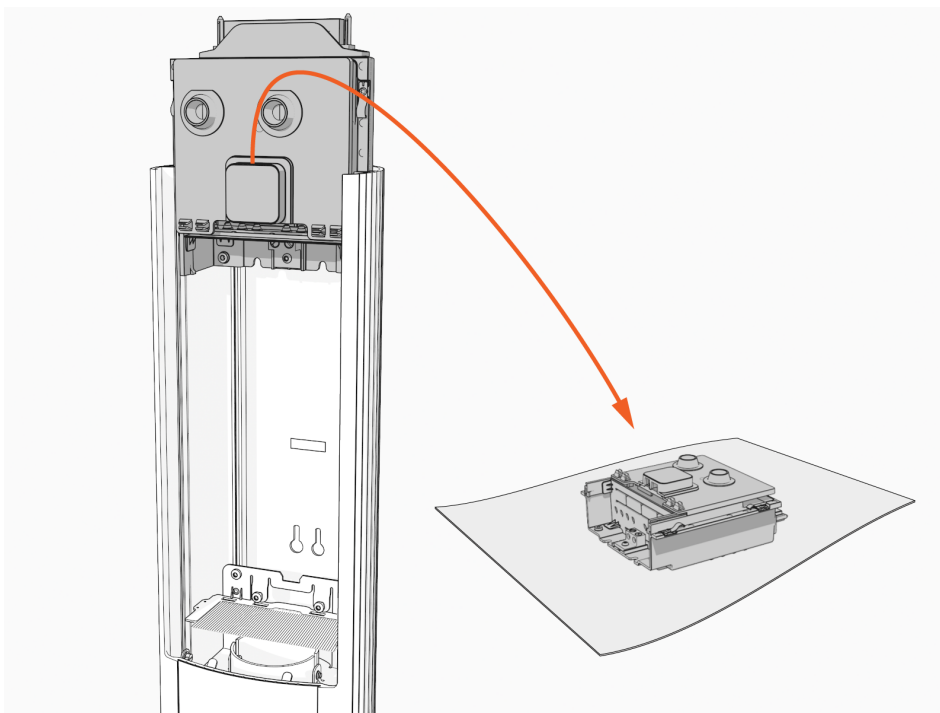

-
3. Drill or use the knockouts in the housing to create holes for the conduit. If drilling holes, drill near the center of the lower housing plate.
 - a. 33 mm (1.3 in) knockout
 - b. 24 mm (0.95 in) knockout (optional Ethernet wiring)

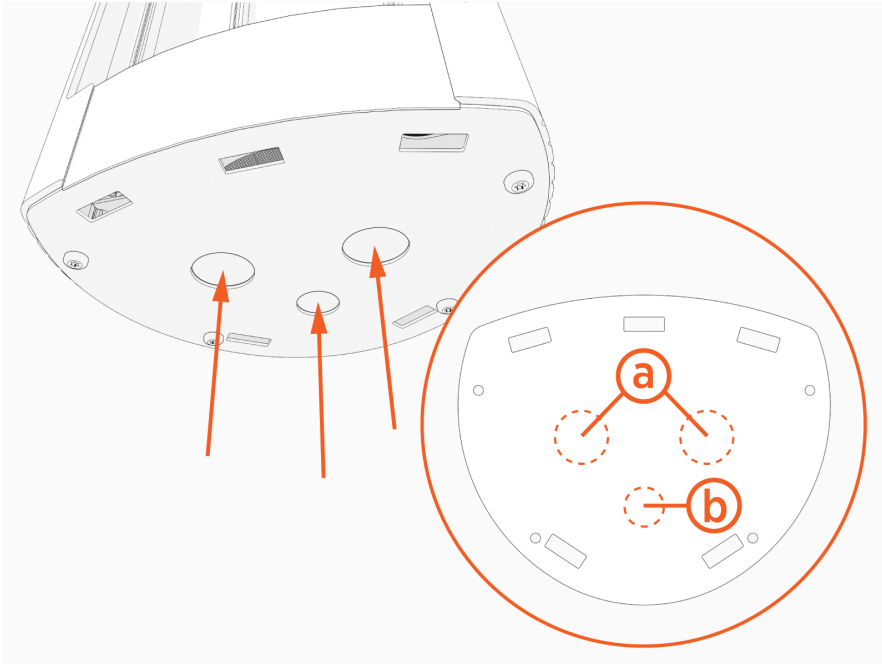

Maximum sizes for larger conduit:

- Two 40 mm (1.5 in) conduits (power in), 0.75 inch conduit (optional Ethernet)
- One 68 mm (2.5 in) conduit (power in), 0.75 inch conduit (optional Ethernet)

4. Snap lower bracket onto station.

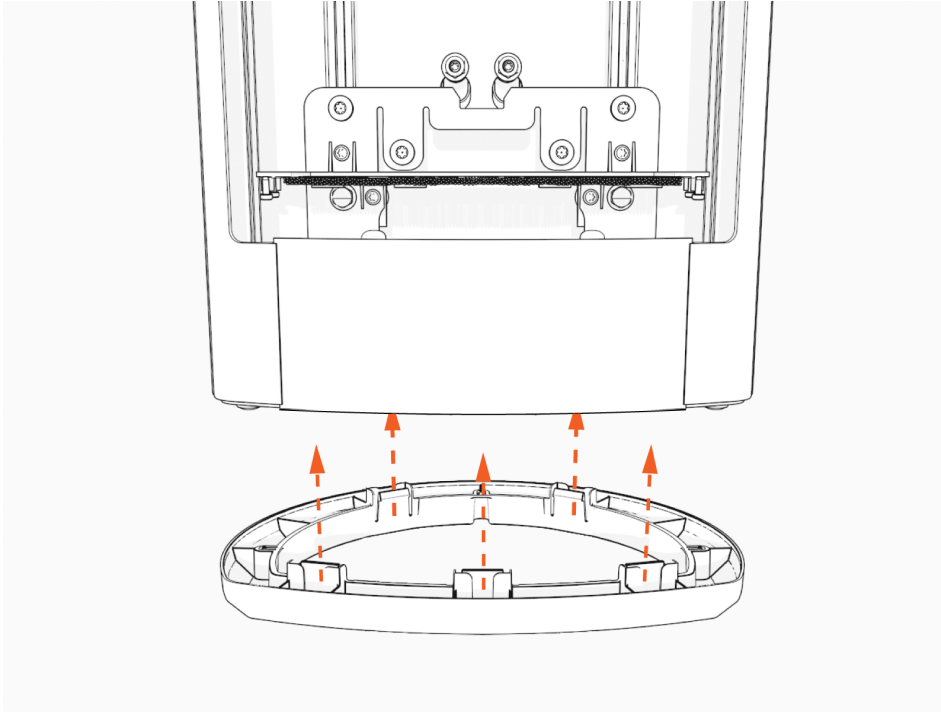

Install the Housing

1. Insert two flange bolts (a) half way through the upper bracket.
2. Insert two threaded posts and nuts (b) on the bottom bracket.

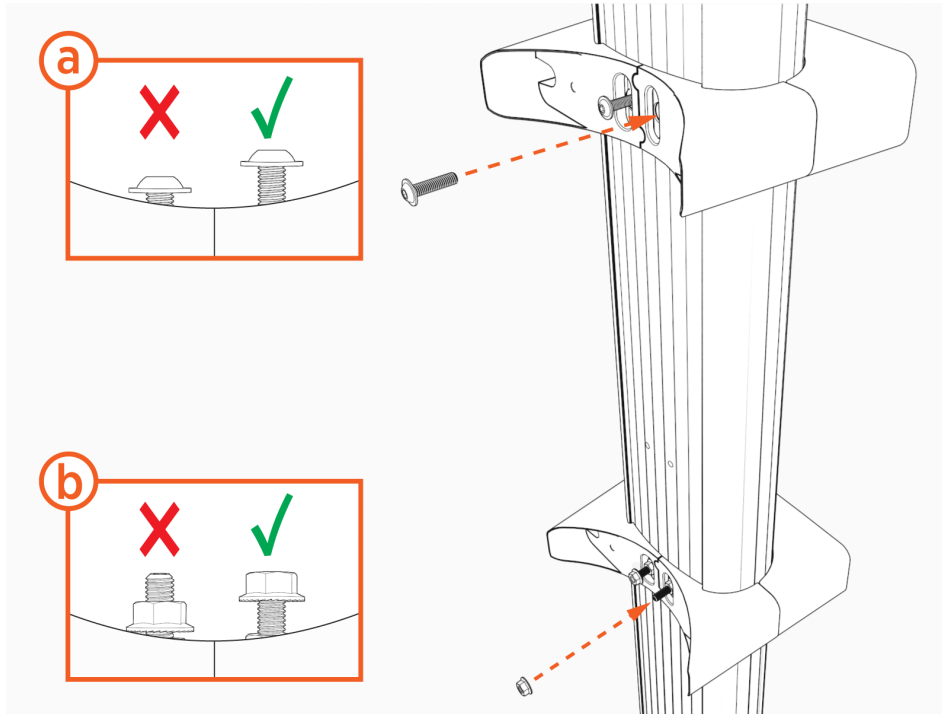

3. Align the mounting screws (top) and nuts (bottom) and hang the housing.

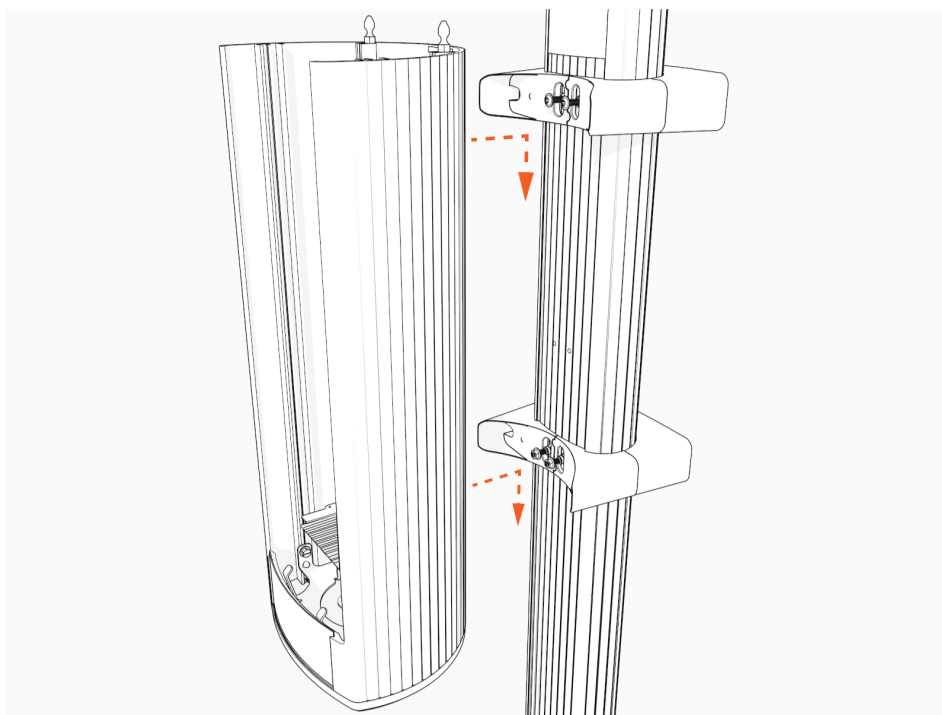

4. Use L-wrench or mini-ratchet wrench to torque two flange screws (upper) and two preinstalled nuts (lower) to 5.7 Nm (50 in-lb).

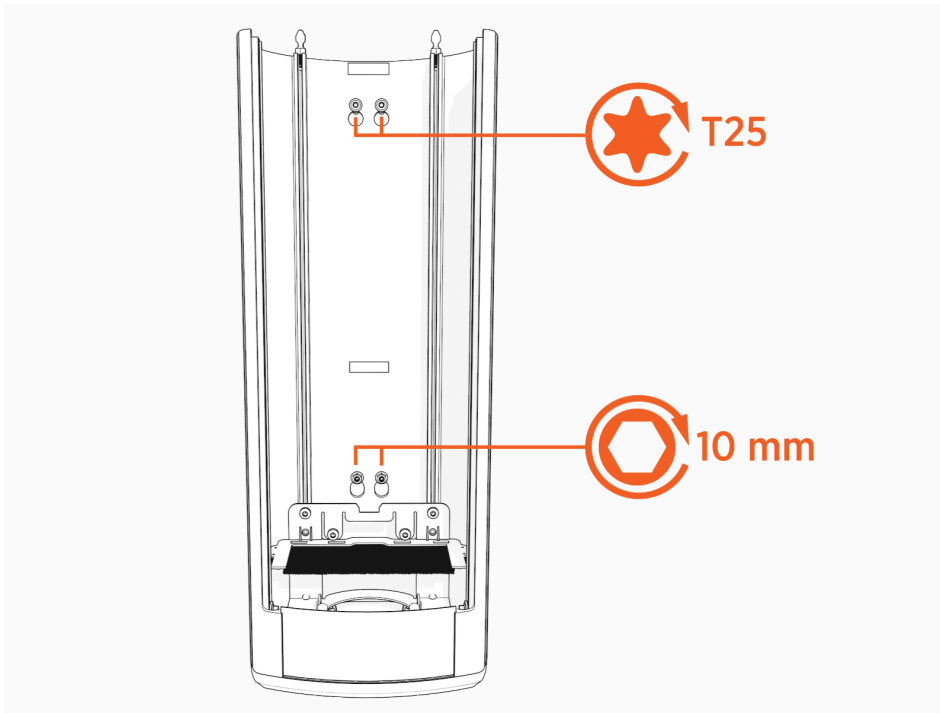

Install the Conduit

1. Feed conduit through lower station bracket and into station.

The length of wire available from the end of the conduit or the wall mount base must be at least 300 mm (12 in).

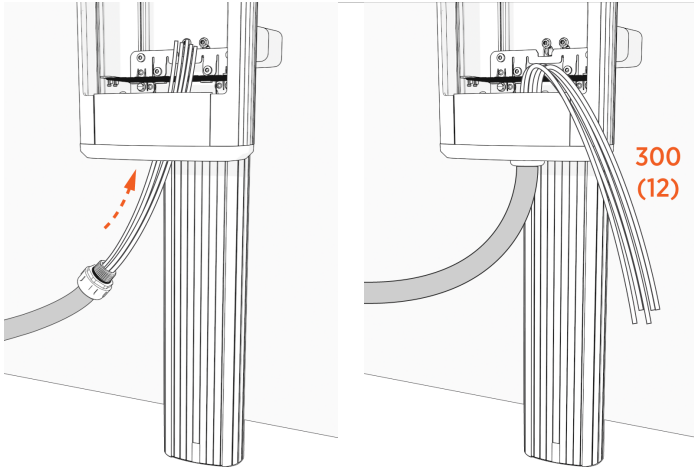

2. Select the appropriate gland or hardware and sealant, if applicable, to attach the conduit to the station.

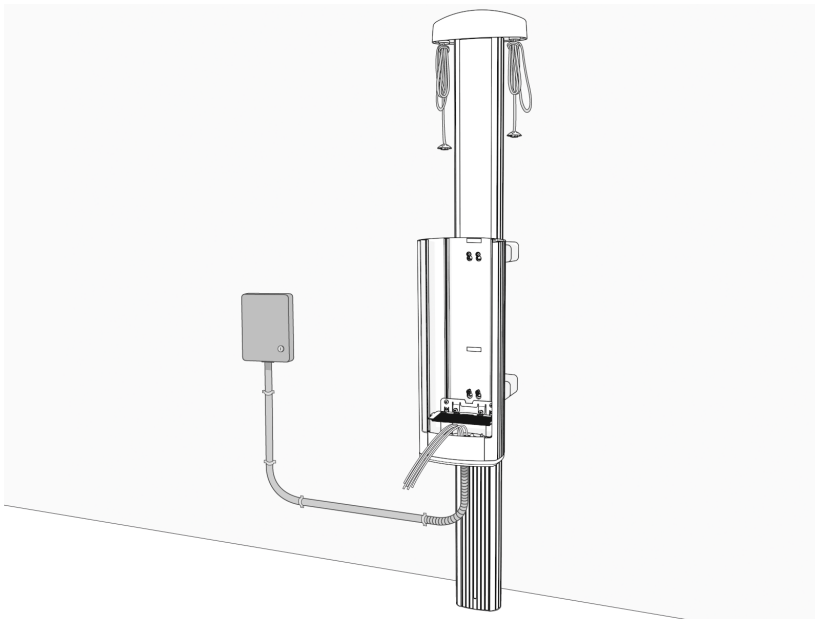

IMPORTANT: Install and seal the conduit following local codes.

After installing the wall mount, go to [Connect Wiring - North America](#).

Connect Wiring - North America 4

CAUTION: Use copper conductors only.

Do not provide GFCI protection at the panel. The CP6000 has built-in GFCI protection.

In areas with frequent thunderstorms, add surge protection at the service panel for all circuits. Use new circuit breakers only.



Ensure all power and ground connections (especially those at the breaker) are clean and tight. Remove all oxide from all conductors and terminals before connecting wiring.

Although neutral is not used by CP6000 charging stations, system neutral must be bonded to ground so that all line to ground voltages are defined.

Grounding Requirements

CP6000 charging stations must be connected to a grounded, metal, permanent wiring system. An equipment-grounding conductor must be run with circuit conductors and connected to an equipment-grounding terminal on the charging station.

A grounding conductor that complies with applicable codes must be grounded to earth at the service equipment or, when supplied by a separate system, at the supply transformer, or may be grounded to an earth electrode. Ensure the grounding conductor complies with all applicable codes.

Connect To These Systems

- 120/240 VAC, 1Ø Bonded Neutral
Station is connected to L1 and L2
Neutral is not used

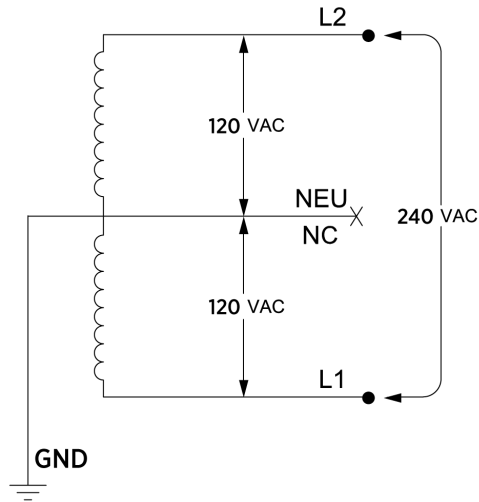

- 120/208 VAC, 3Ø Wye Bonded Neutral
Station may be connected to any two lines
Neutral is not used

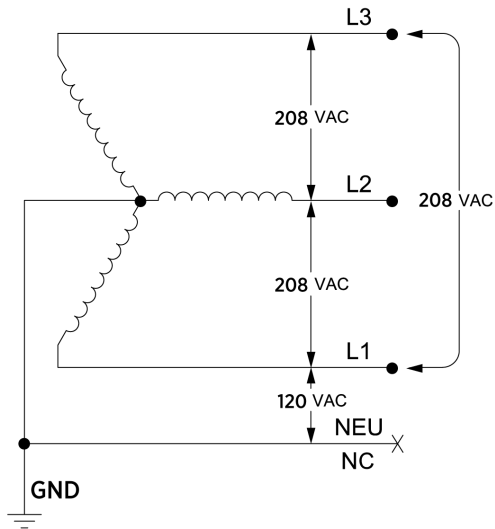

Do Not Connect to These Systems

- 208 VAC 3Ø Wye, ungrounded
Floating Neutral
Voltage of either line to ground is undetermined
Neutral is not grounded

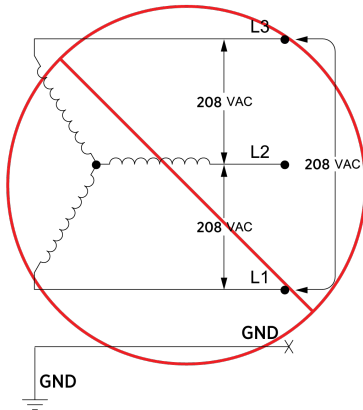

- 120/240 VAC 3Ø Delta, corner-grounded
Voltage of any line is not 120 V nominal relative to ground
- Any system where the center point of the AC power source is not grounded.

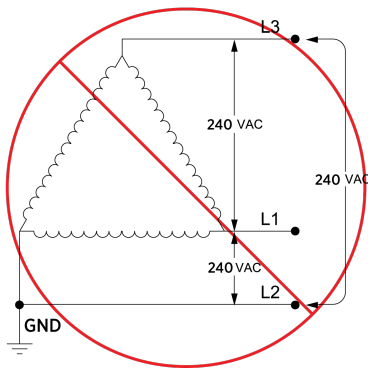

Install Circuit Sharing Jumpers

Circuit sharing jumpers may be required for certain station installations. These include:

- Single port stations
- Single circuit installations to supply power to dual port stations

Jumpers are included with charging stations.



IMPORTANT: Circuit sharing jumpers cannot be installed with the Power Plate in the housing.

If the station is not being configured for circuit sharing, go to [Install the Power Plate](#).



WARNING: Install jumpers only when one circuit feeds one or both ports. Installing jumpers while feeding a circuit to each port will result in shorting occurring across the lines.

1. Install the jumpers. You must install both of the jumpers.

Do not terminate wires on either of the two specific terminals that are being fed by a jumper.

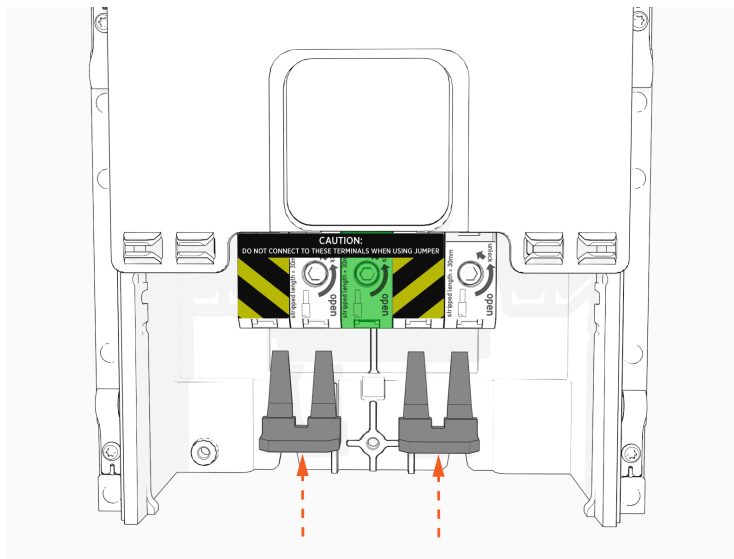

IMPORTANT: Ensure circuit sharing jumpers are fully seated.

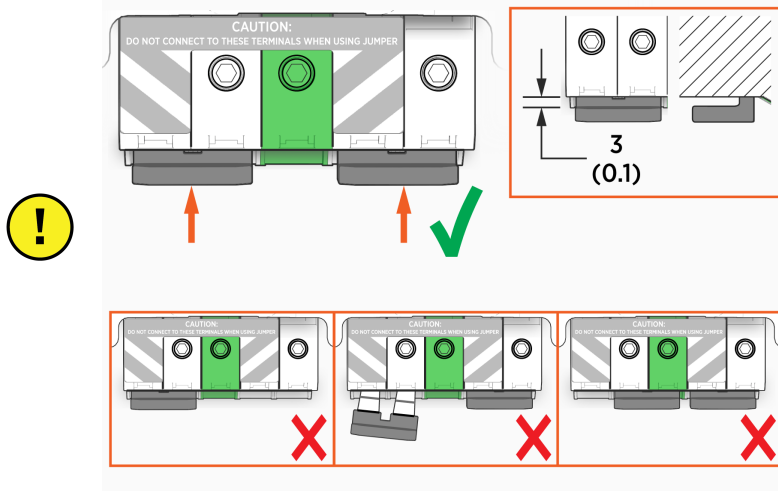

Install the Power Plate

1. Align the power plate with the housing and slide it down until it touches the metal bracket.
2. Ensure the power plate is seated correctly.
3. Slide the power plate block cover up.
4. Using a T25 driver, torque the screws to 5.7 Nm (50 in-lb) to secure the power plate.

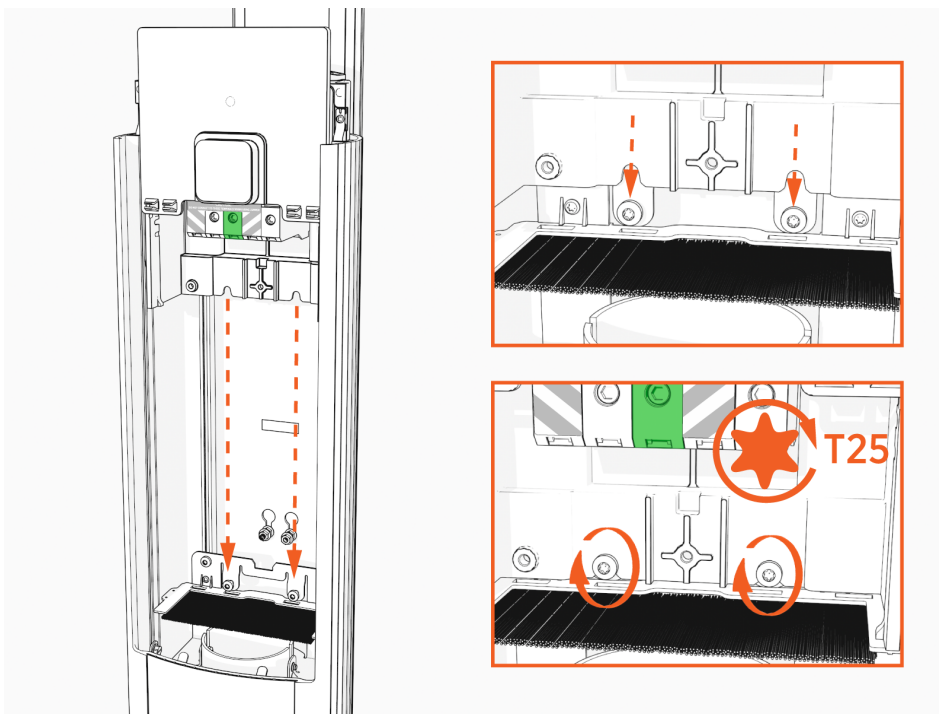

Connect the Wiring

- 1. Strip the wires 30 mm (1 3/16 in).

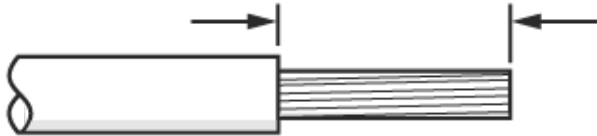

IMPORTANT: Cut wires straight across at 90° and not at an angle.



- To open the center terminal block, insert an 8 mm (5/16 in) hex driver and rotate it counter-clockwise. You might need to lift the label flap to access the terminal block.

Hold the driver in place to keep the terminal open while inserting the wire.

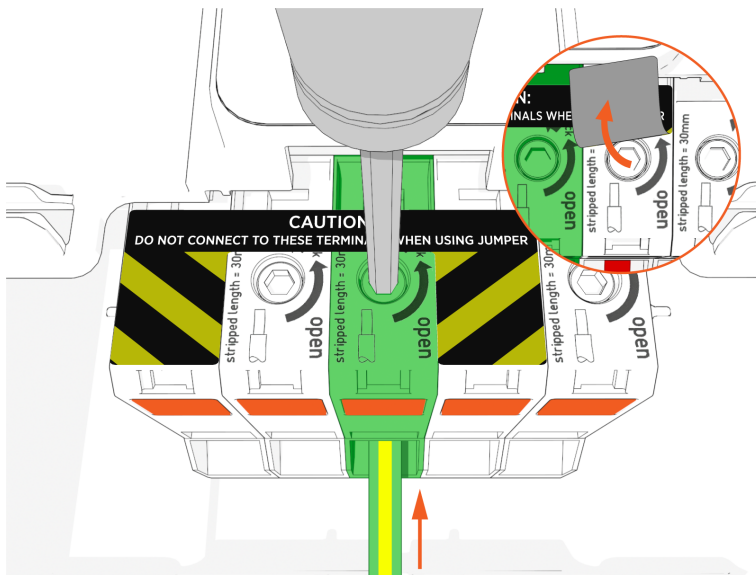
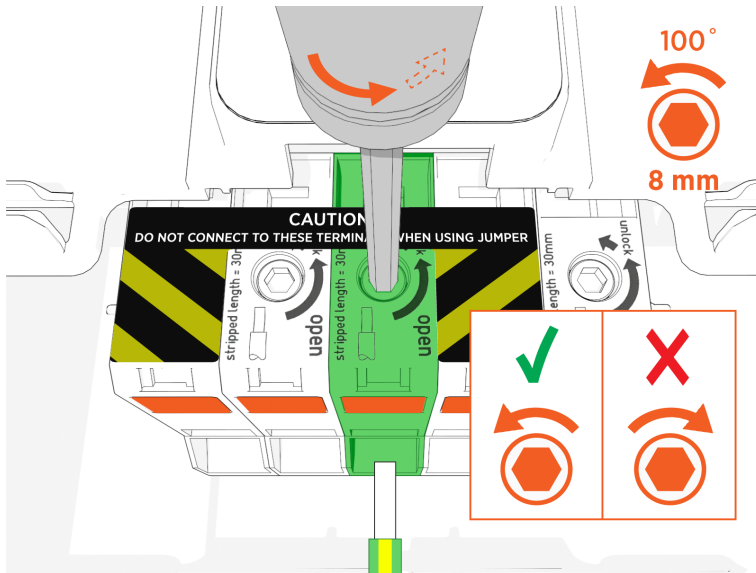

IMPORTANT: If you use the orange button to lock the terminal block in the open position, use only counter-clockwise rotation to release it. Rotating the tool clockwise will damage the terminal block.

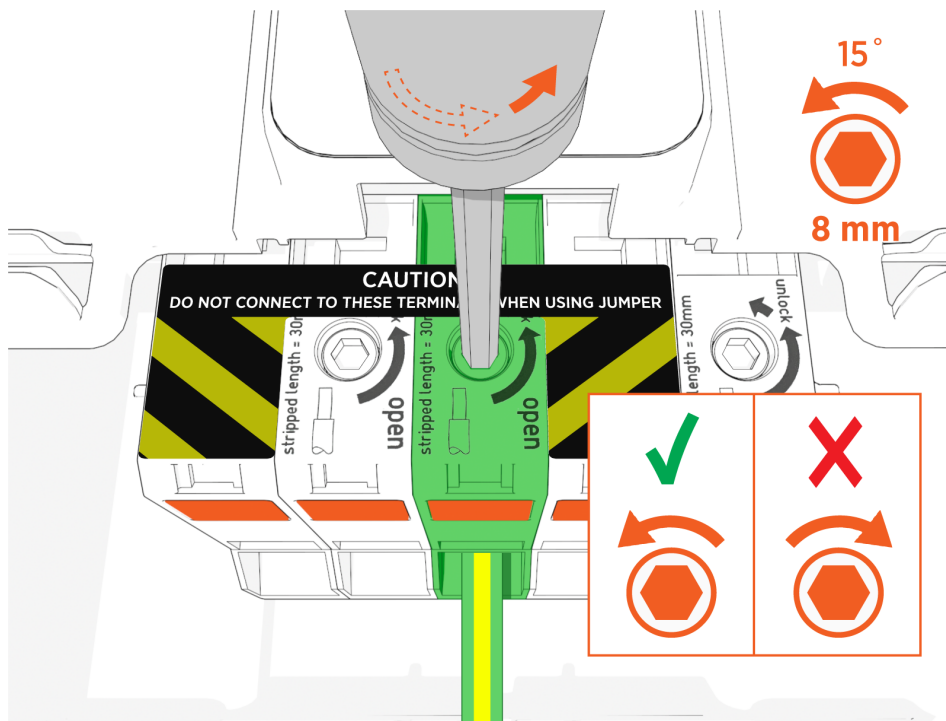

3. Insert the ground wire into the center terminal.

Note: Make sure the wire is fully seated and no bare wire is visible outside the terminal block.

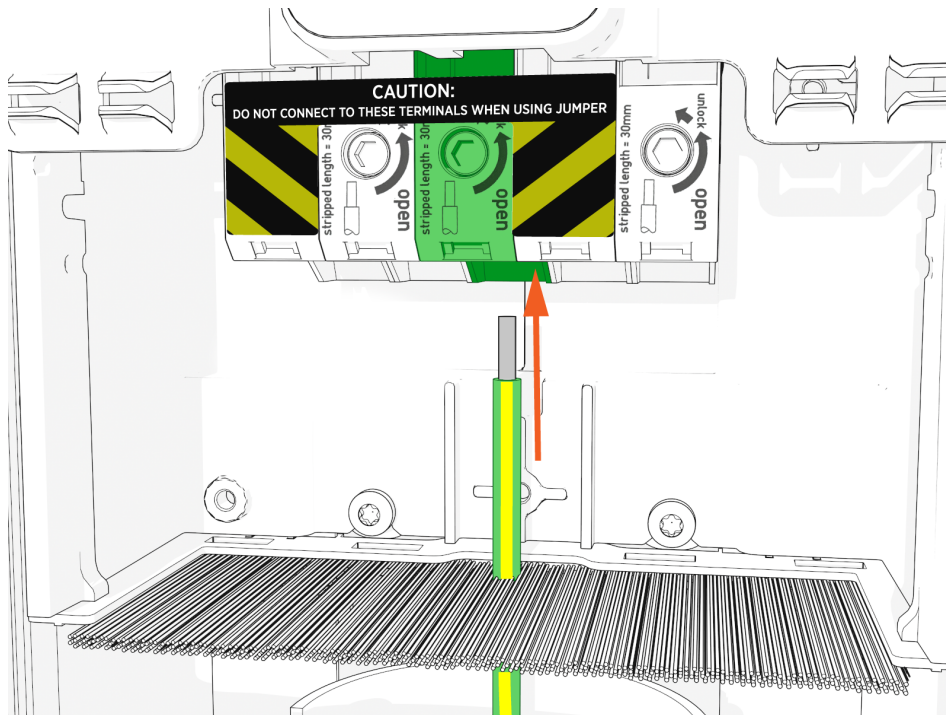

4. While holding the wire in place, release the hex driver to secure the wire in the terminal block.
5. Repeat previous steps for each wire.

6. Take a picture of the completed terminal block wiring with labels to submit during pinpointing.



IMPORTANT: Ensure that you take a photo of the wires in the terminal block before continuing the installation process.

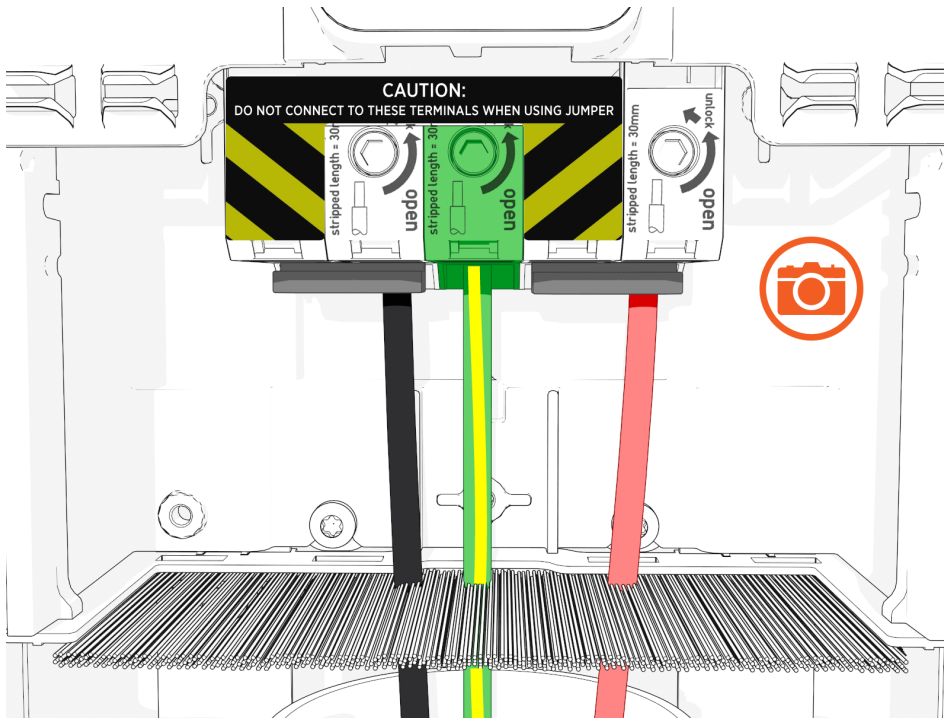

IMPORTANT: You should not see any copper wire outside the terminal block.

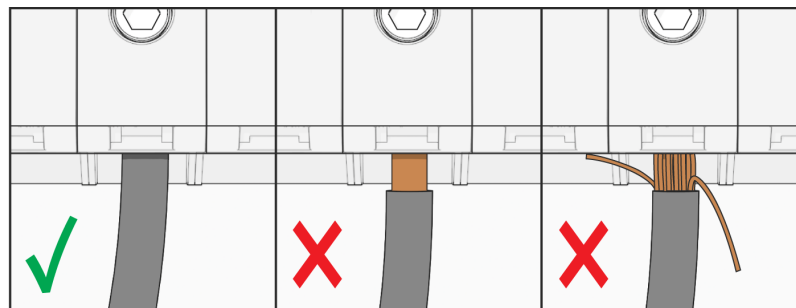

Wiring Diagrams

These diagrams show wiring for installing single and dual port CP6000 stations on:

- A dual circuit, dual port
- A single circuit, dual port
- A single circuit, single port

The number of dedicated circuits required depends on the type of installation and the power available at the site.

Refer to the CP6000 Datasheet on chargepoint.com/guides for electrical input and output specifications.

208 VAC Single Phase Dual Circuit, Dual Port

- a. L2
- b. L1
- c. Neutral
- d. Main breaker
- e. Neutral bus
- f. Ground bus
- g. Left breaker
- h. Right breaker
- i. L1 left
- j. L1 right
- k. Ground
- l. L2 left
- m. L2 right
- n. Wire strip length
30 mm (1 3/16 in)

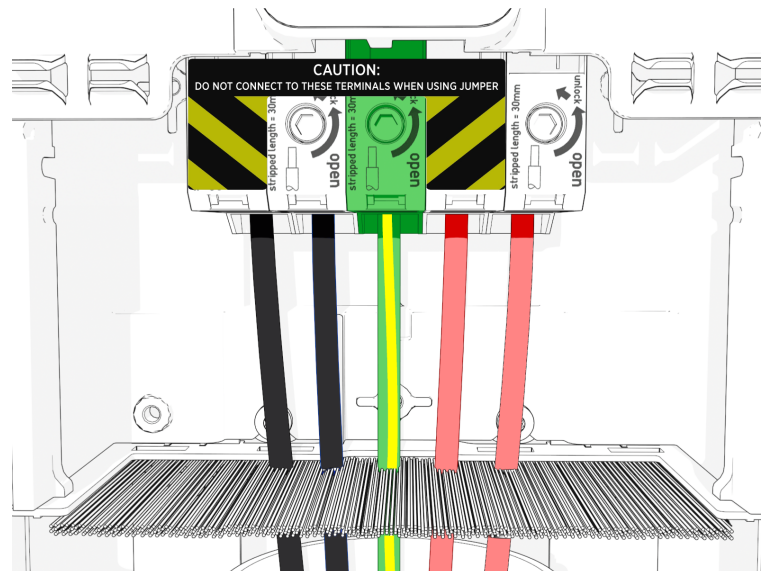
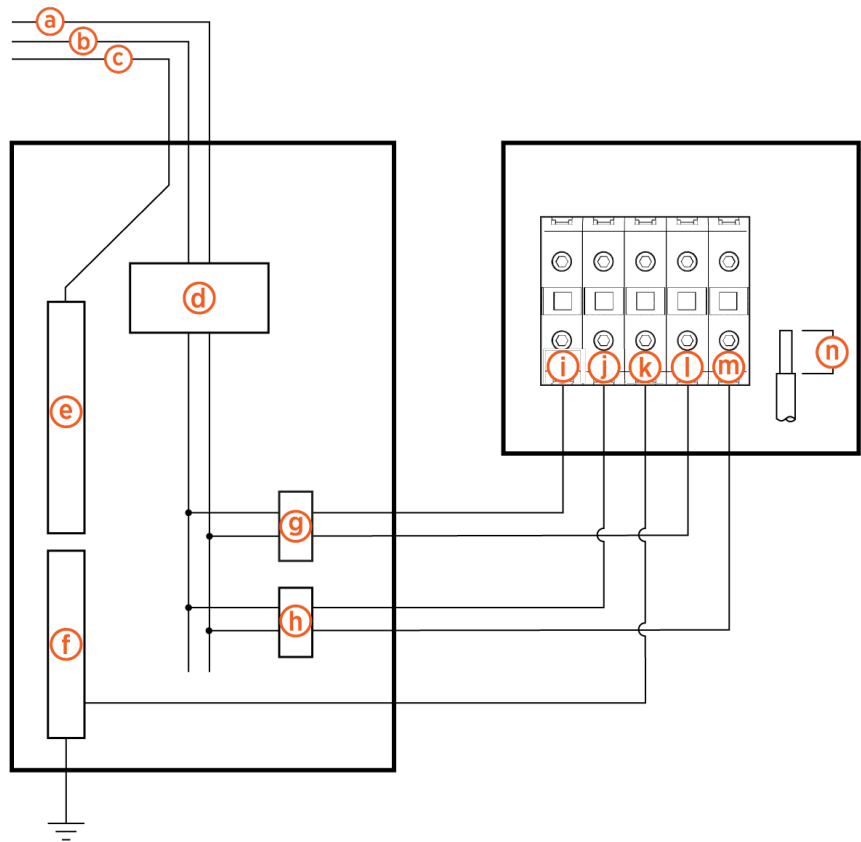

208 VAC Single Phase Single Circuit, Dual Port

- a. L2
- b. L1
- c. Neutral
- d. Main breaker
- e. Neutral bus
- f. Ground bus
- g. Breaker
- h. Ground
- i. L1
- j. L2
- k. Jumper
- l. Wire strip length 30 mm (1 3/16 in)

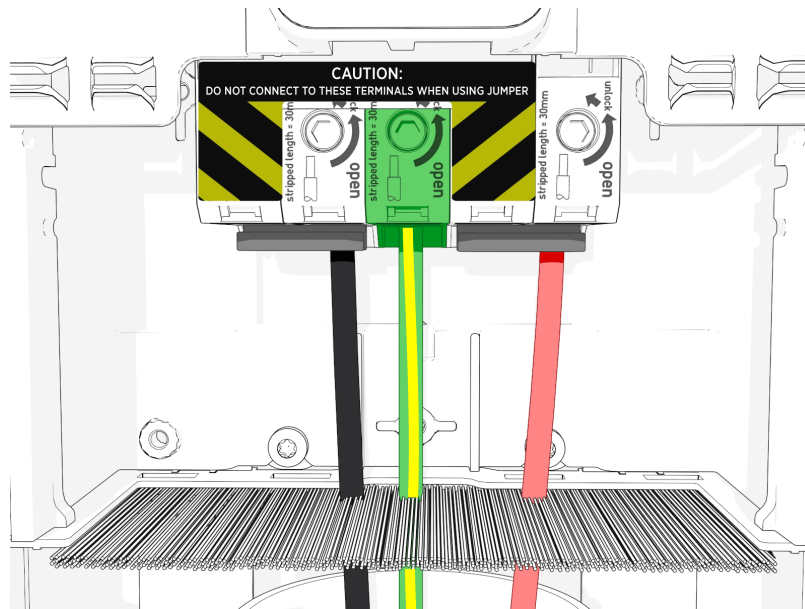
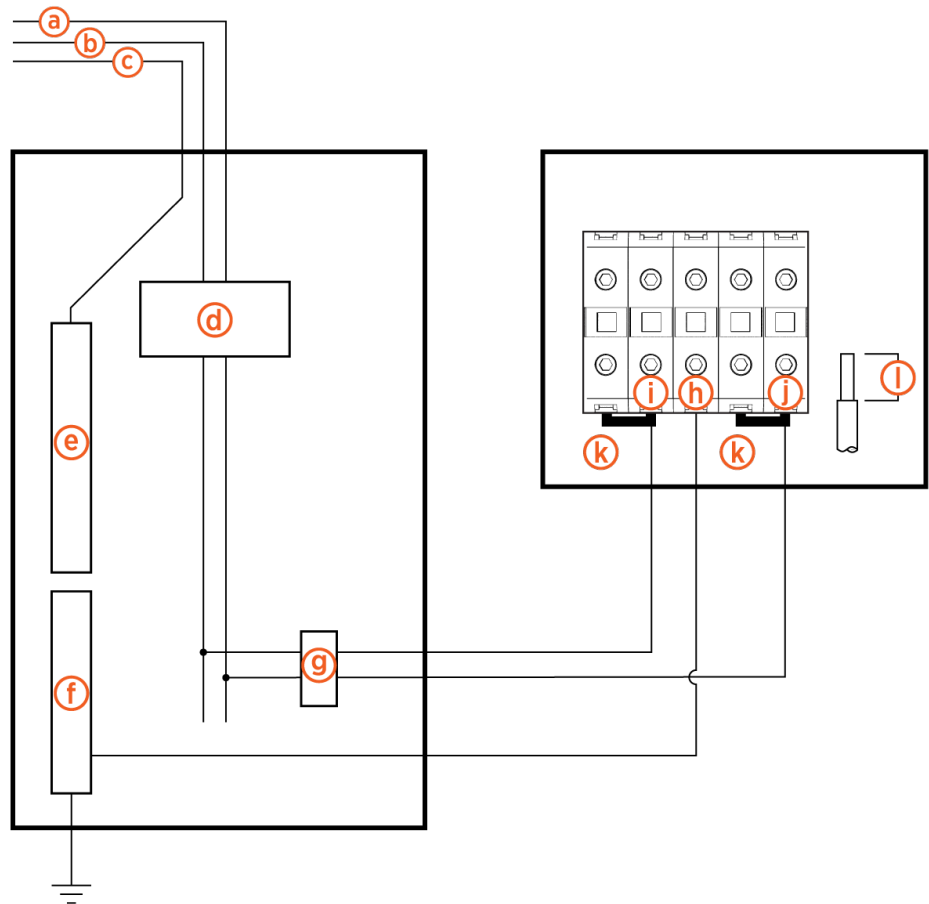

208 VAC Single Phase Single Circuit, Single Port

- a. L2
- b. L1
- c. Neutral
- d. Main breaker
- e. Neutral bus
- f. Ground bus
- g. Breaker
- h. Ground
- i. L1
- j. L2
- k. Jumper
- l. Wire strip length 30 mm (1 3/16 in)

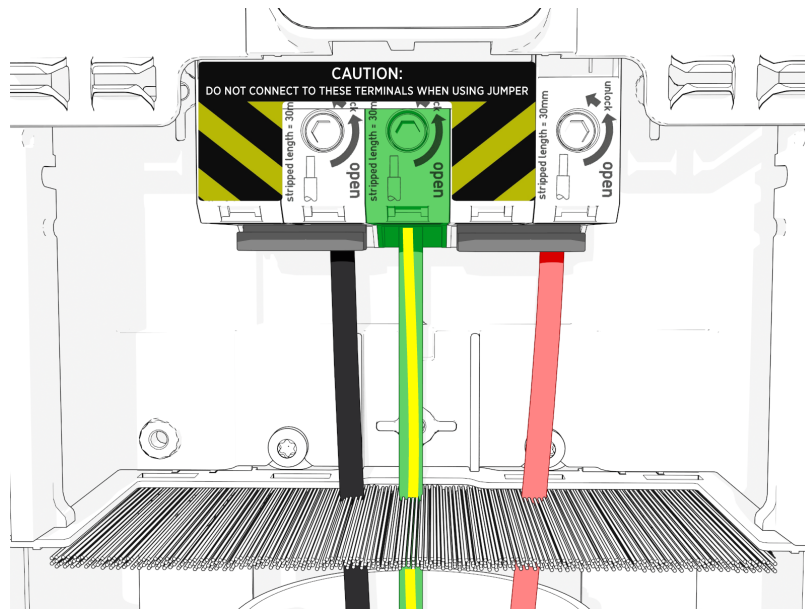
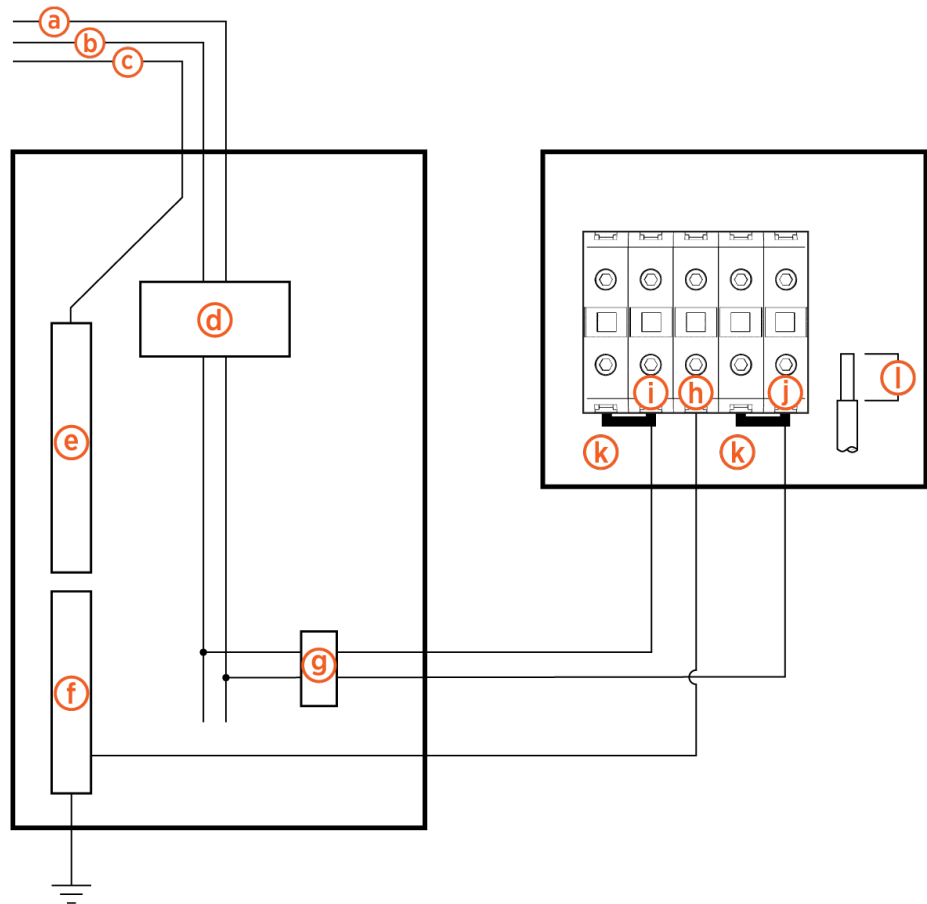

Check Voltages



IMPORTANT: Ensure that Neutral connects to ground in the system per applicable codes.

The following table lists the expected input voltage measurements.

Measure Between	VAC (Plus or Minus 10%)
L1R - L2R	208/240
L1L - L2L	208/240
L1R - GND	120
L2R - GND	120
L1L - GND	120
L2L - GND	120

1. Turn power ON at the circuit breaker panel.
2. Using a solenoid type voltmeter, check that the voltages at the charging station's terminal block are as listed in the table above.
 - Insert the meter probes into the holes at the top of each terminal block and check the input voltage.
 - If the voltages are not within 10% of the voltages in the table above, ensure the wiring has been properly connected. Refer to the detailed wiring diagrams in this chapter.
 - For grounding requirements, see the CP6000 Datasheet on chargepoint.com/guides.
3. Resolve any wiring issues and ensure voltages are correct.
4. Turn power OFF at the circuit breaker panel.

Assemble the Station 5

Connect the Head Assembly

1. Lower the power plate cover.

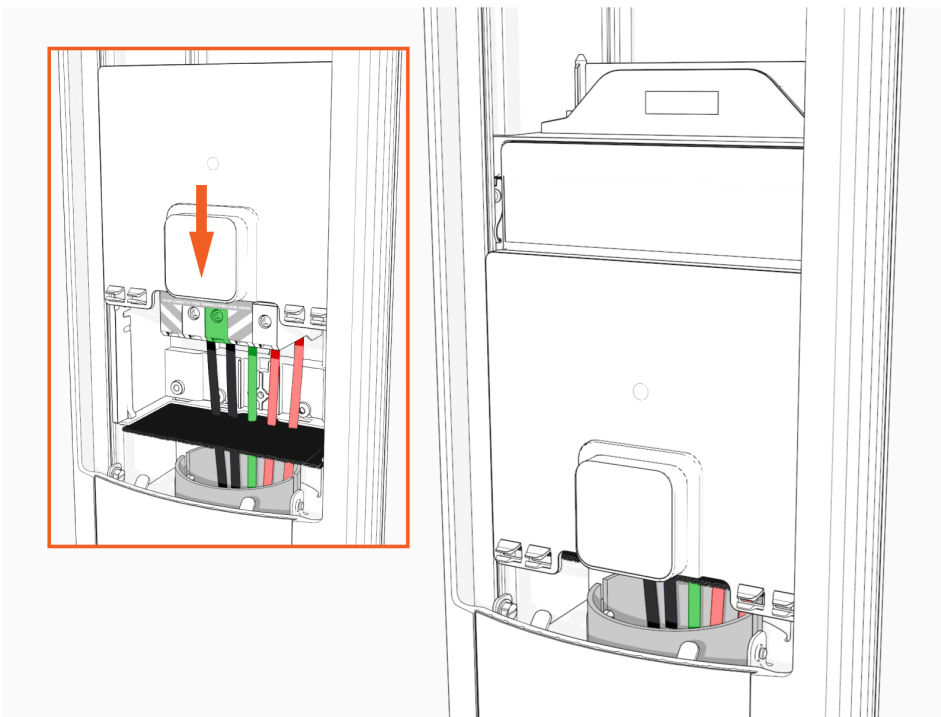

2. Open the head assembly package.
3. Remove the head assembly from the packaging.



IMPORTANT: Hold the metal castings on the sides of the head assembly, not the plastic front cover, to avoid damaging the front cover.

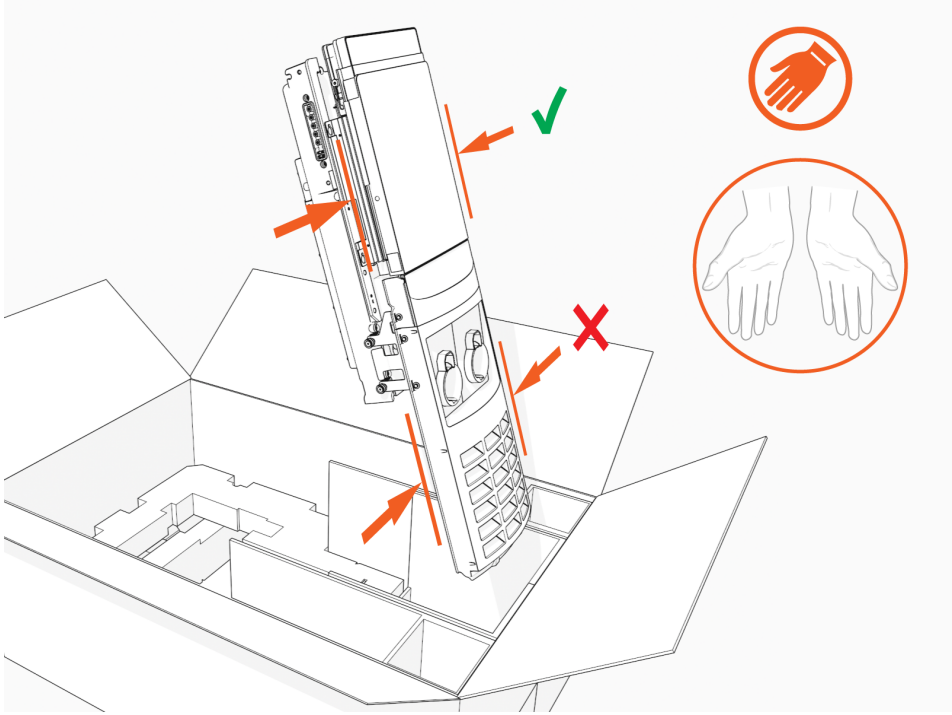

4. Align the rails on the head assembly with the pedestal and slide it into the pedestal housing.

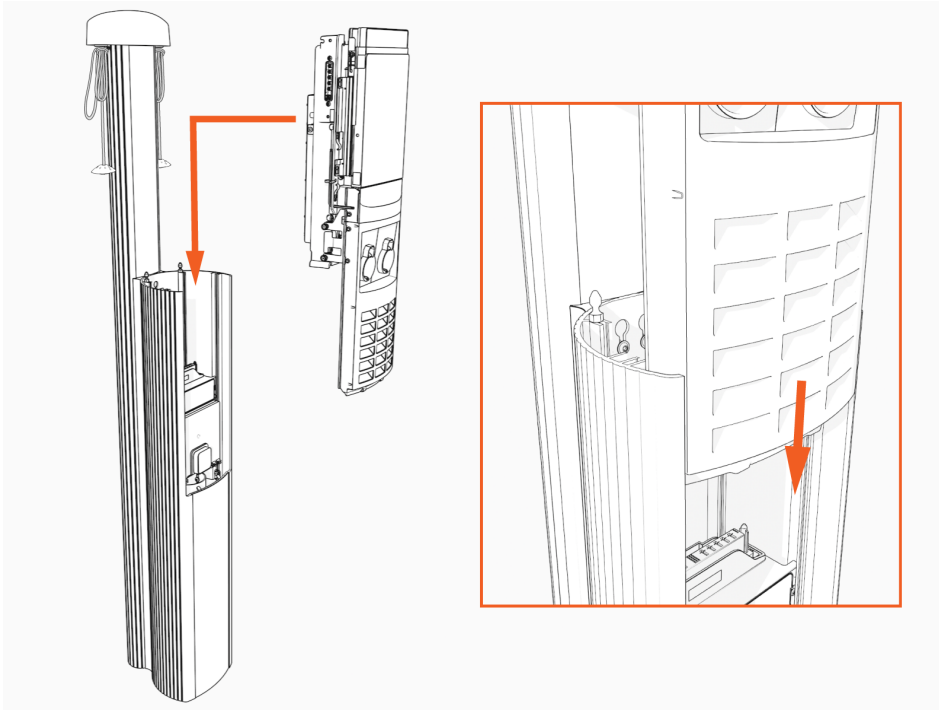

The head assembly rests on the L-wrench connected to the side of the assembly.

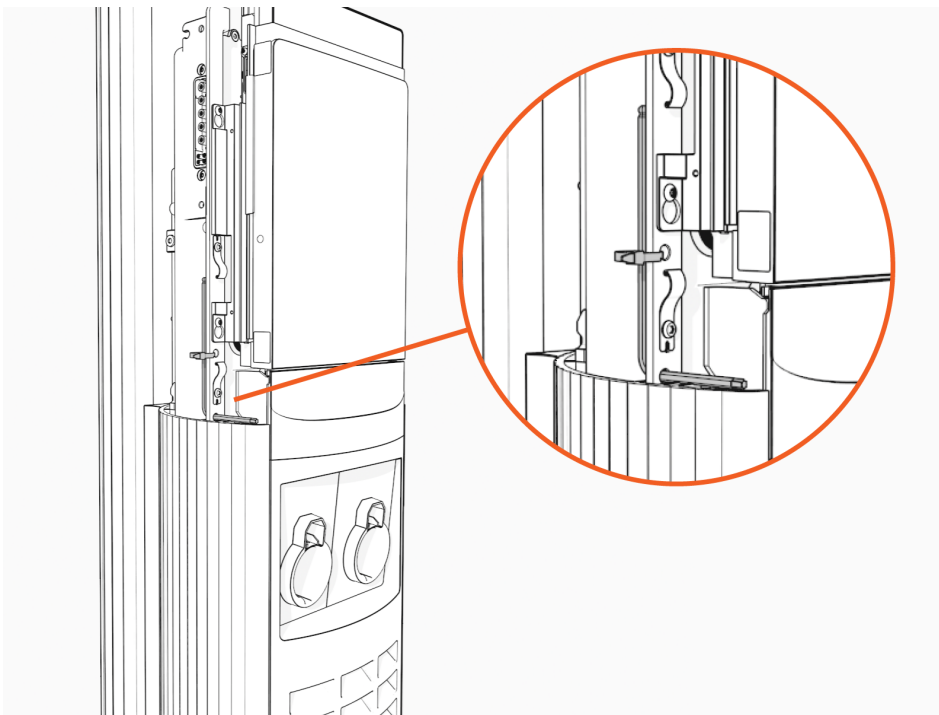

5. Loosen, but do not remove, the screws that secure the Control and Communications Unit (CCOM) to the head assembly.

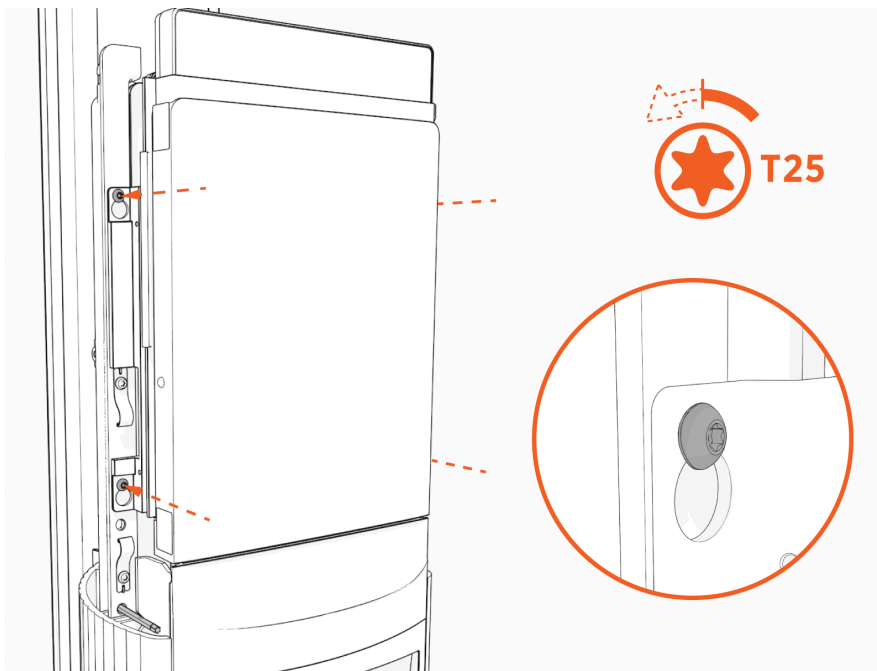

6. Lift the CCOM up and tilt it away from the head assembly.
The bottom edge of the CCOM rests on the upper edge of the holster assembly.

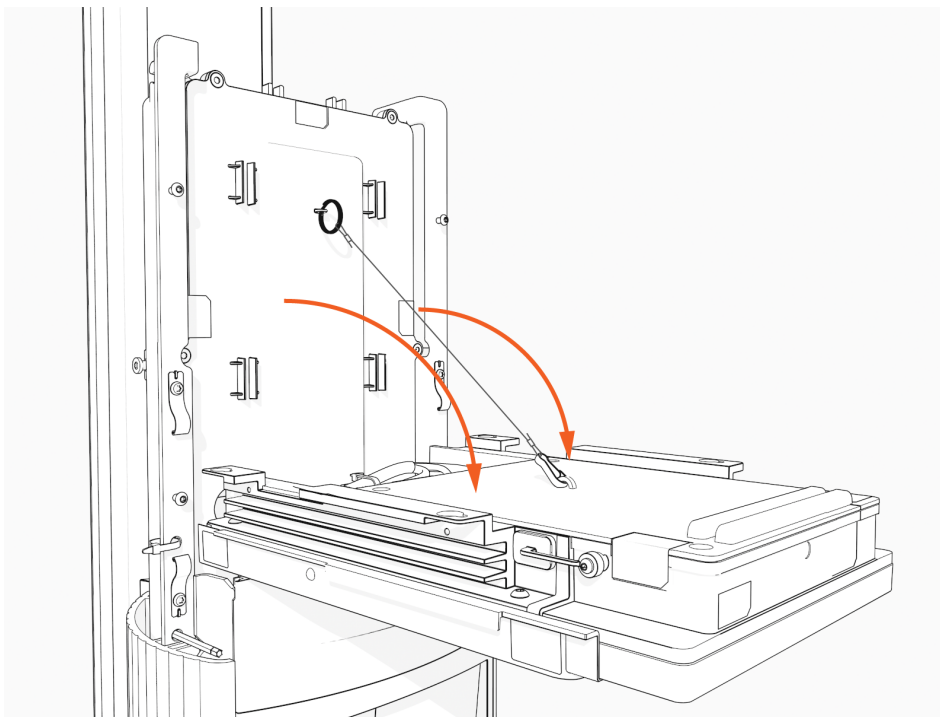

7. Ensure there is no visible damage to the connector pins.

Attach the smart cable by partially engaging one screw and then partially engaging the second screw.

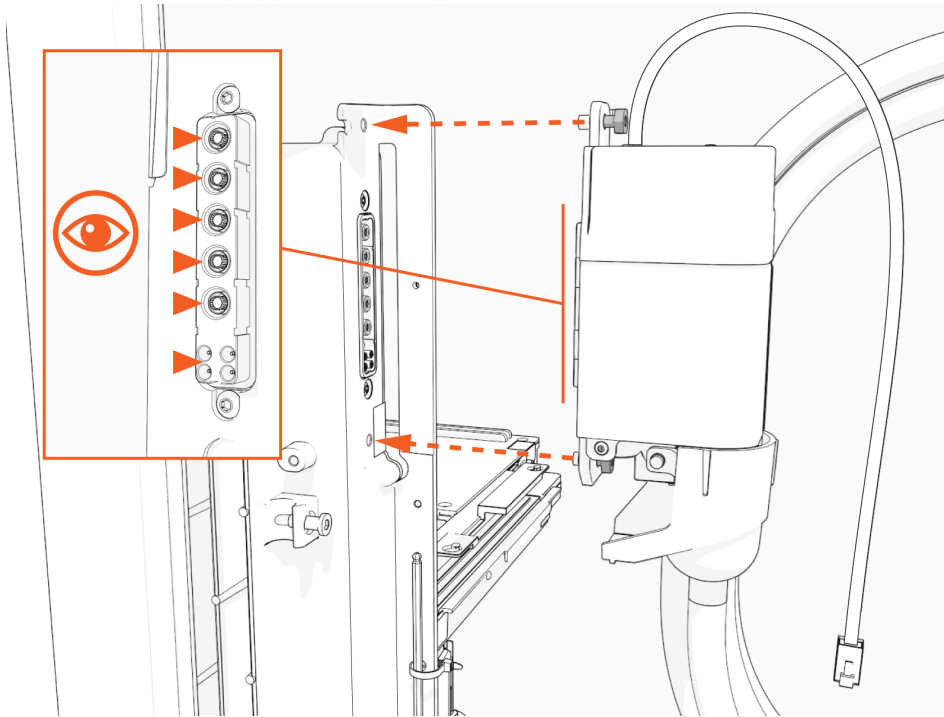

8. On single port stations, attach the smart cable to the **right** side as you are facing the charging station. Connect the blank connector to the left side.

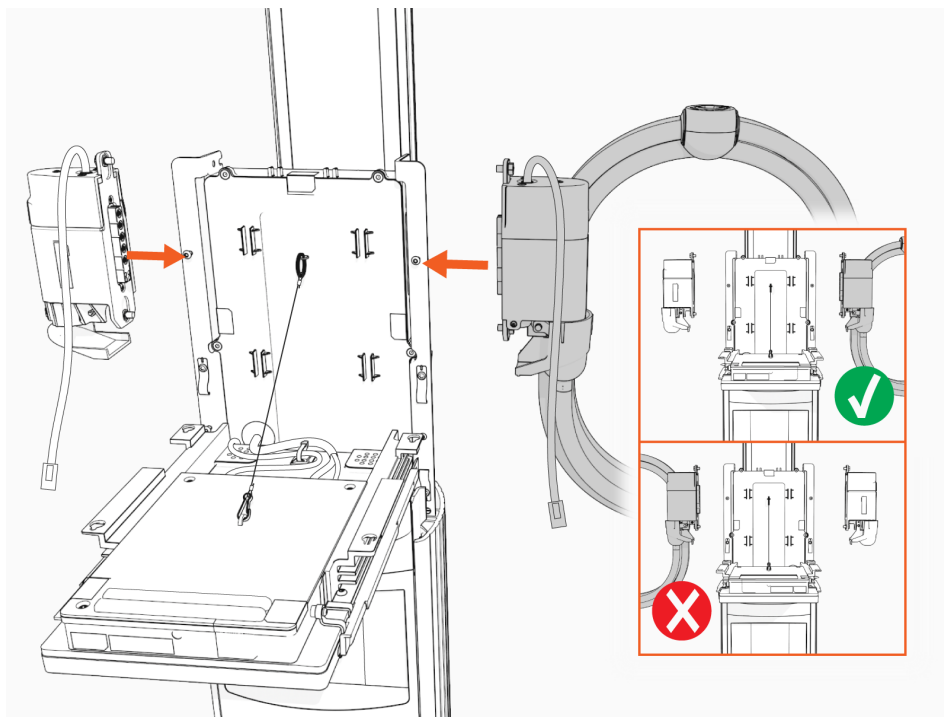

9. Torque both the top and bottom screws to 1.1 Nm (10 in-lb) to secure the smart cable.

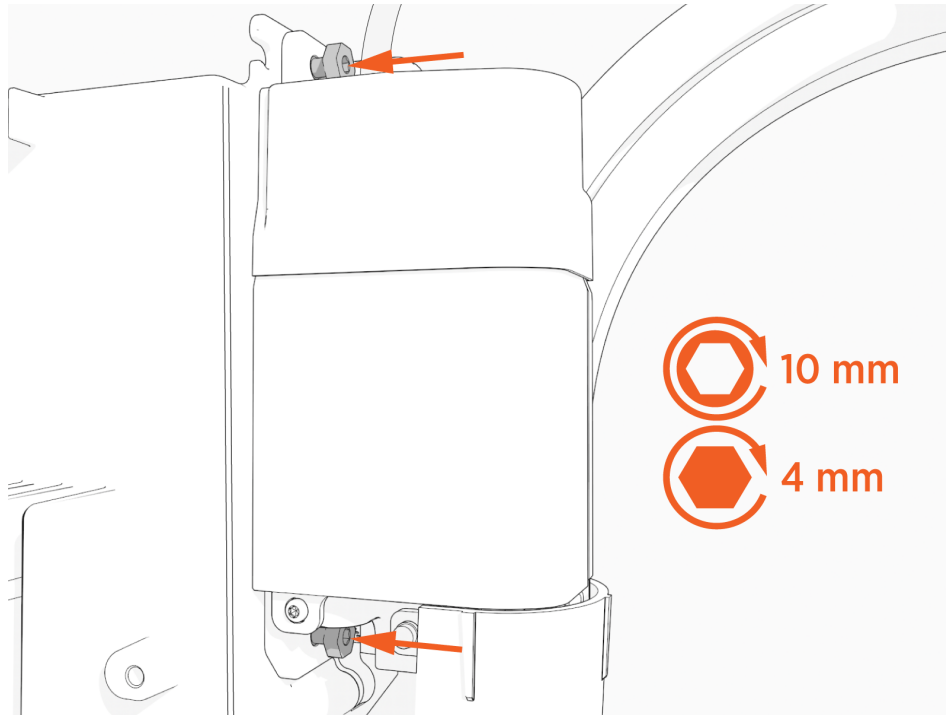

10. Connect the RJ45 Ethernet cables from the smart cable assembly to the bottom of the CCOM.

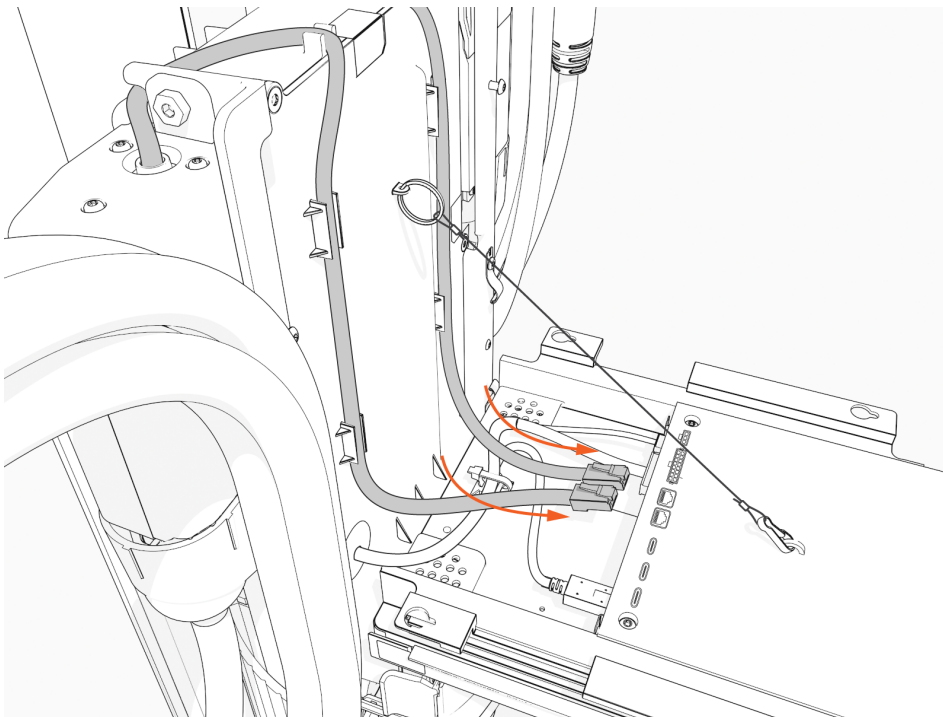

-
11. Slide the RJ45 Ethernet cables into the slots.

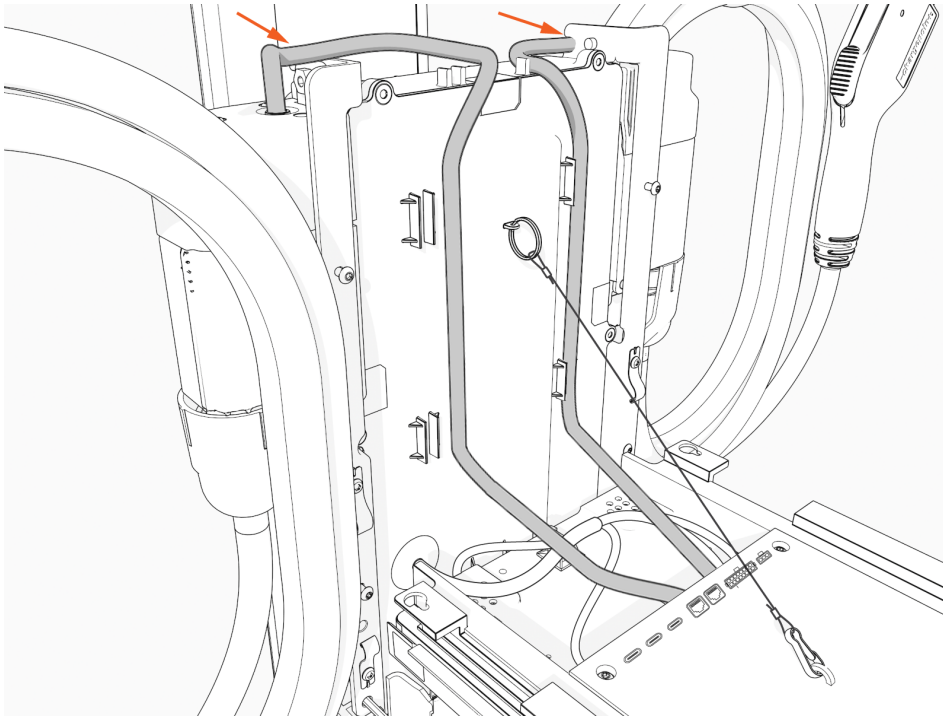

12. Raise the CCOM and slide it into place on the head assembly.

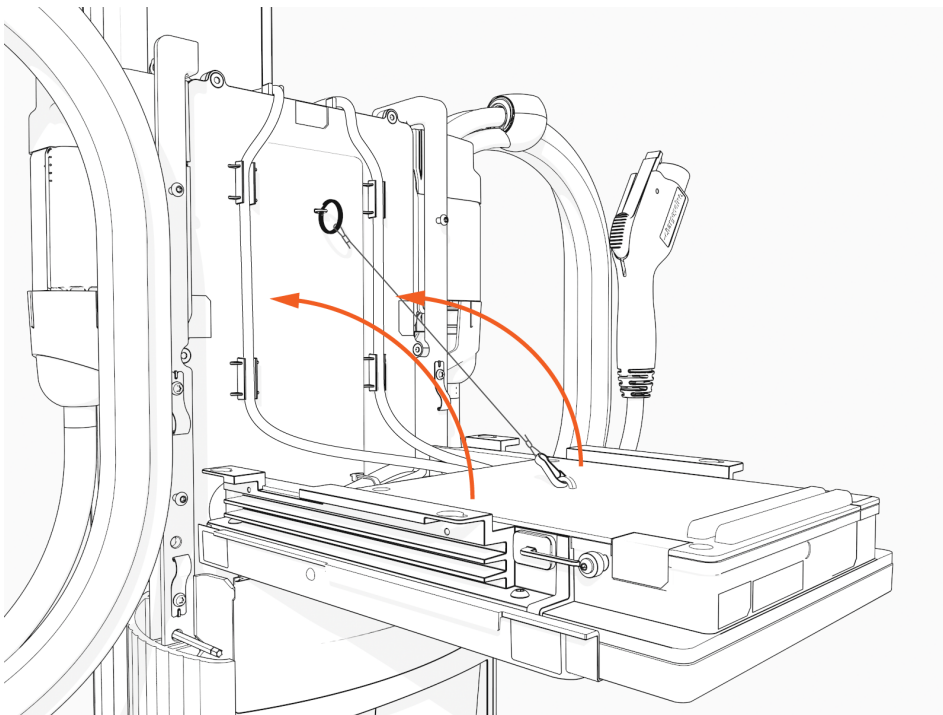

13. Torque the screws to 1.7 Nm (15 in-lb) to secure the CCOM.

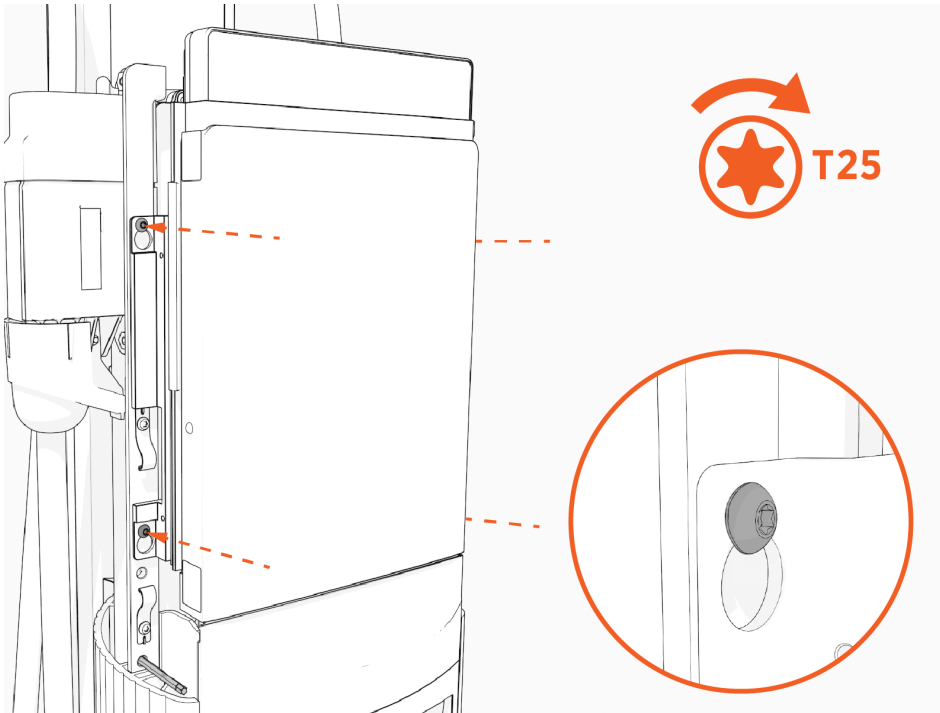

14. Remove the L-wrench.

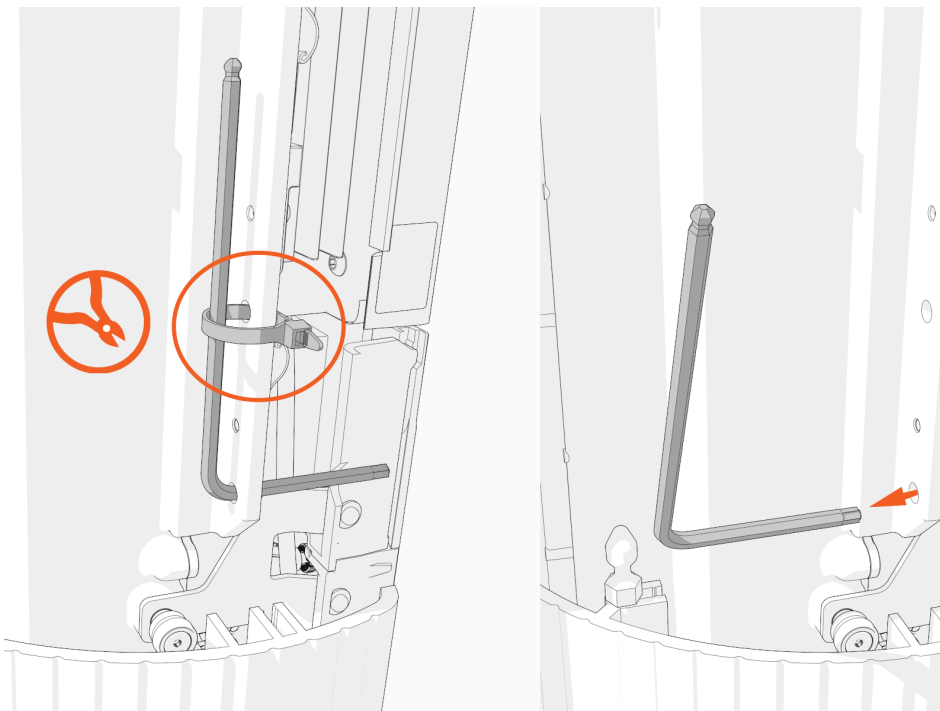

15. Slide the head assembly all the way into the pedestal housing.

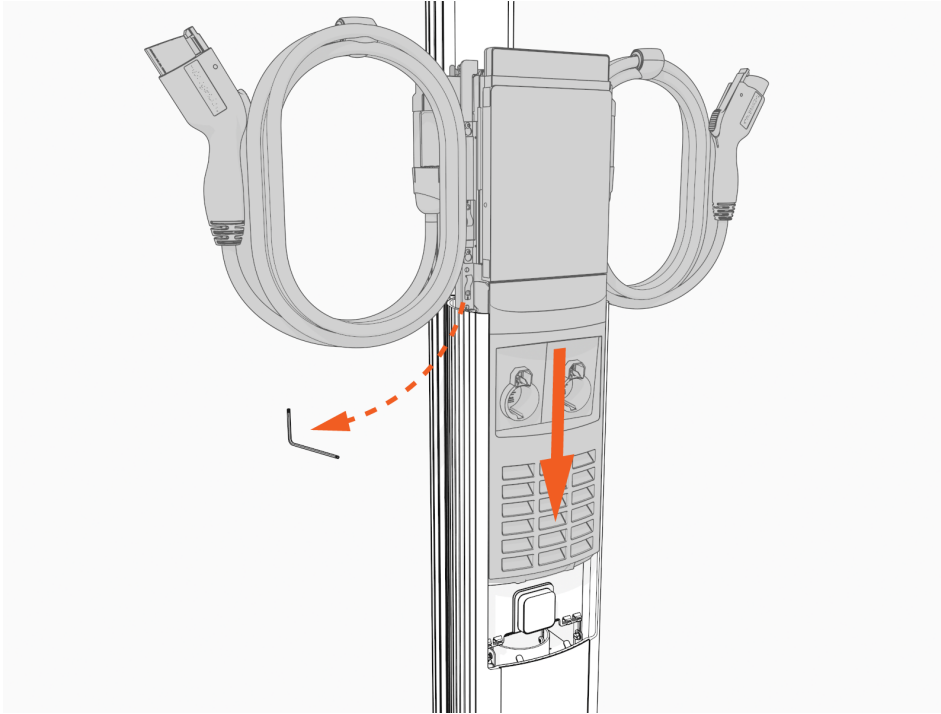

16. Ensure the head assembly is fully seated.

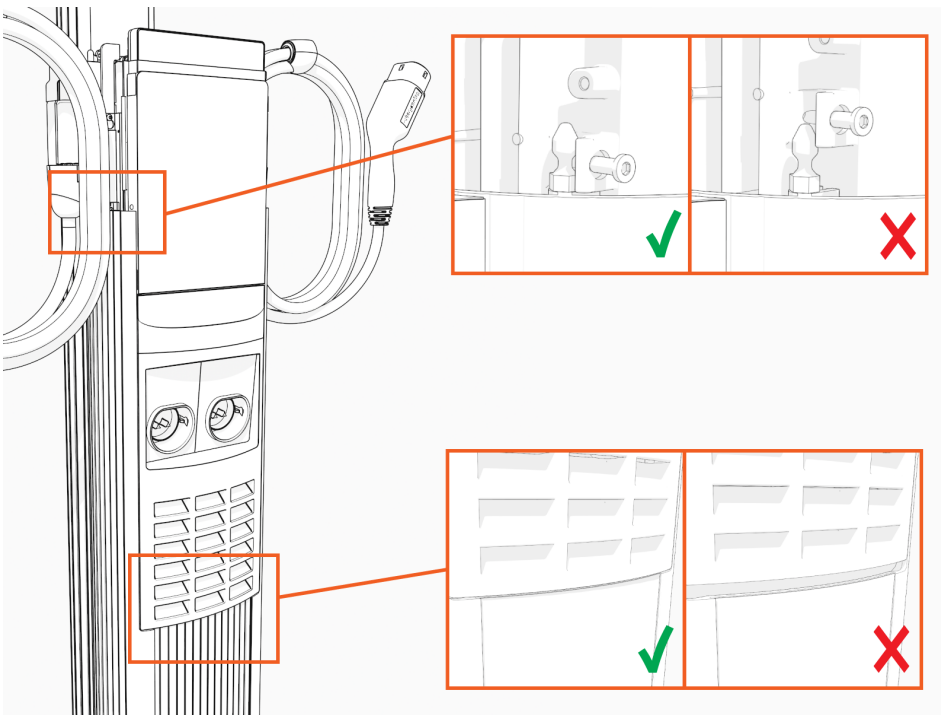

17. Using the L-wrench, tighten two screws.

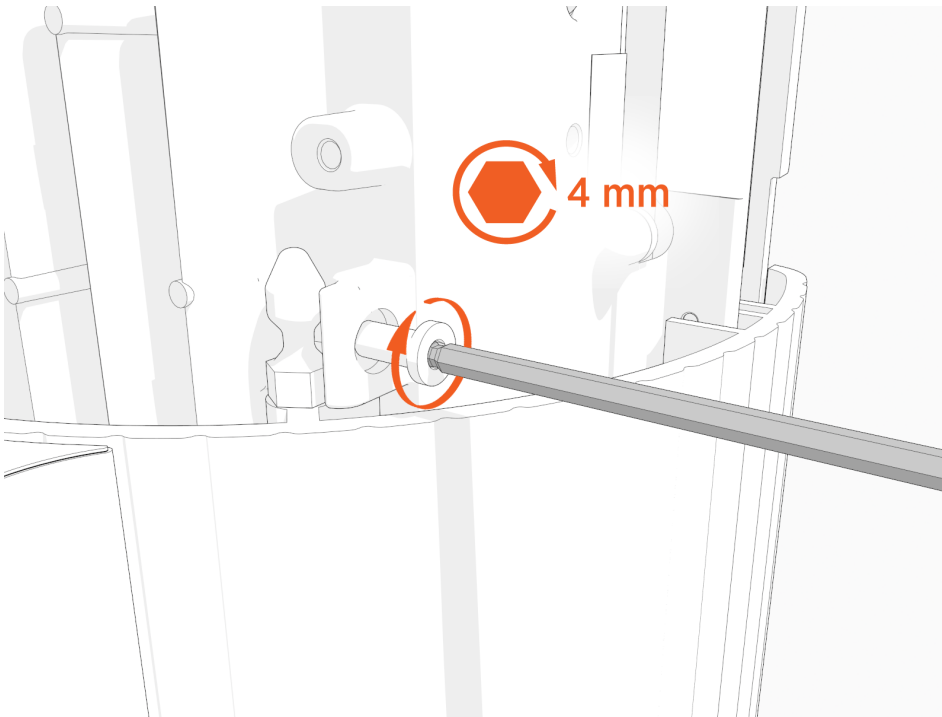

18. Take a picture of the activation label, remove the protective film, and give the protective film with the label to the station owner.

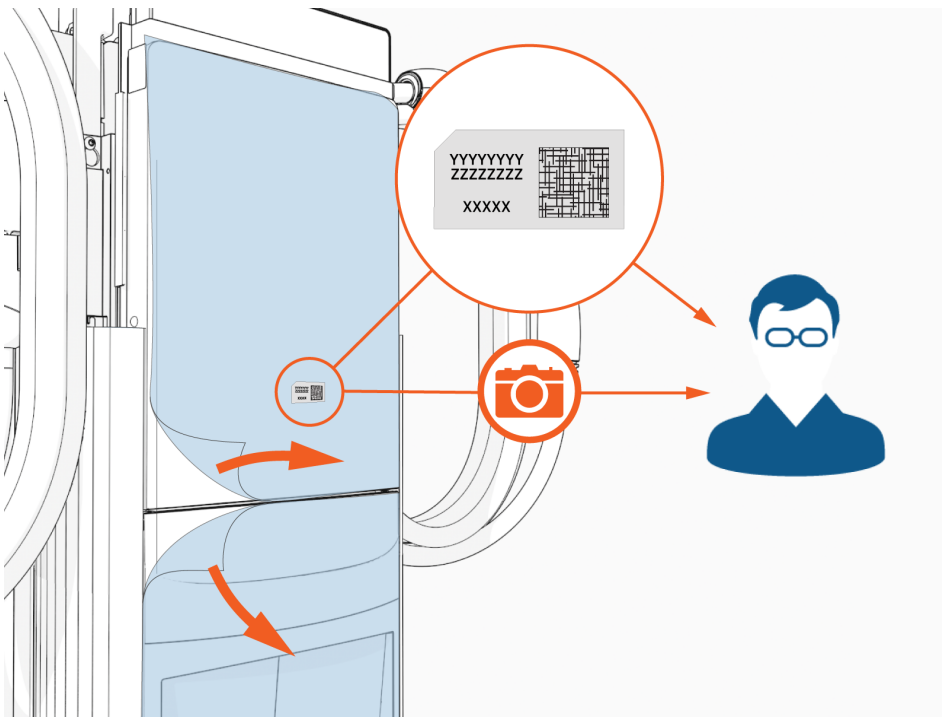

-
19. Slide the top cap onto the head assembly, adjusting as necessary to clear the SEVC cables, until it fits into place.

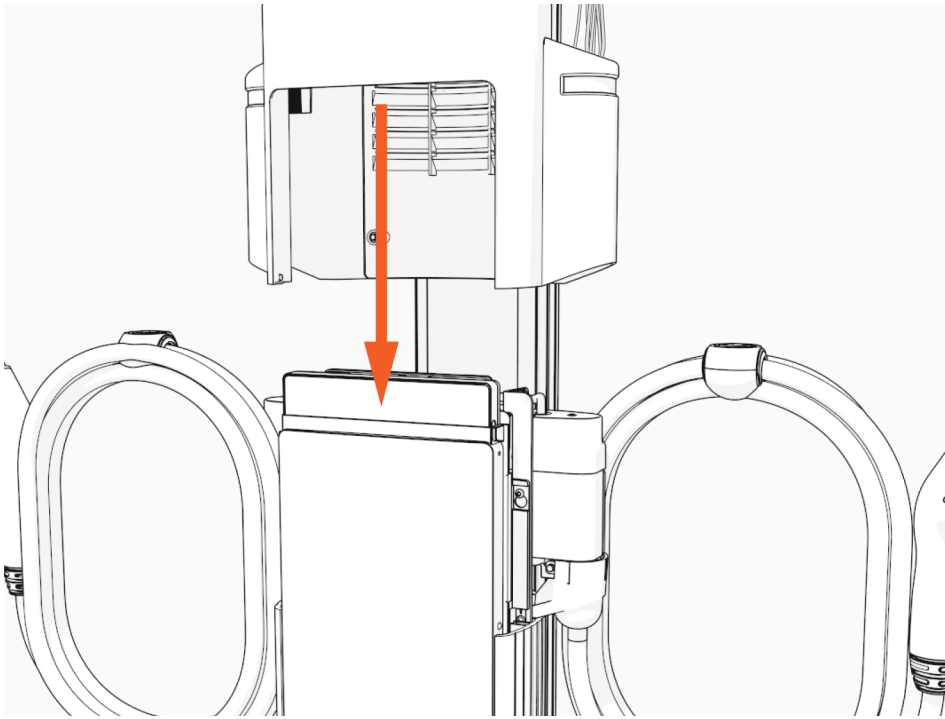

20. Torque two captive screws to 1.1 Nm (10 in-lb).

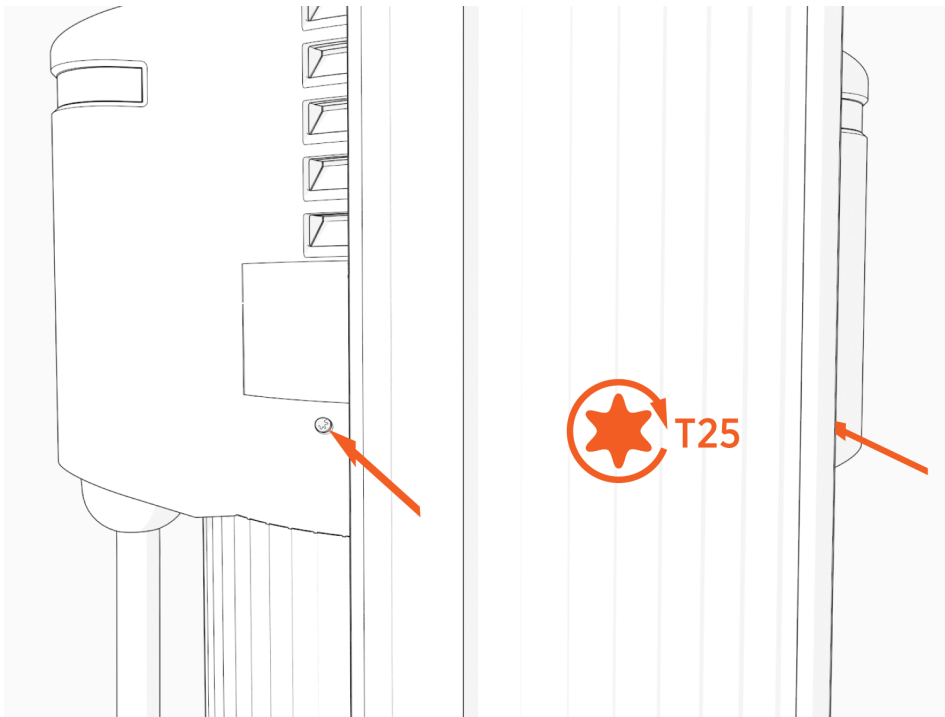

Install Cable Clamps

1. Uncoil the charging cable by gently extending it all the way out and away from the station. Rotate the plug as needed to remove any twist or kinks.

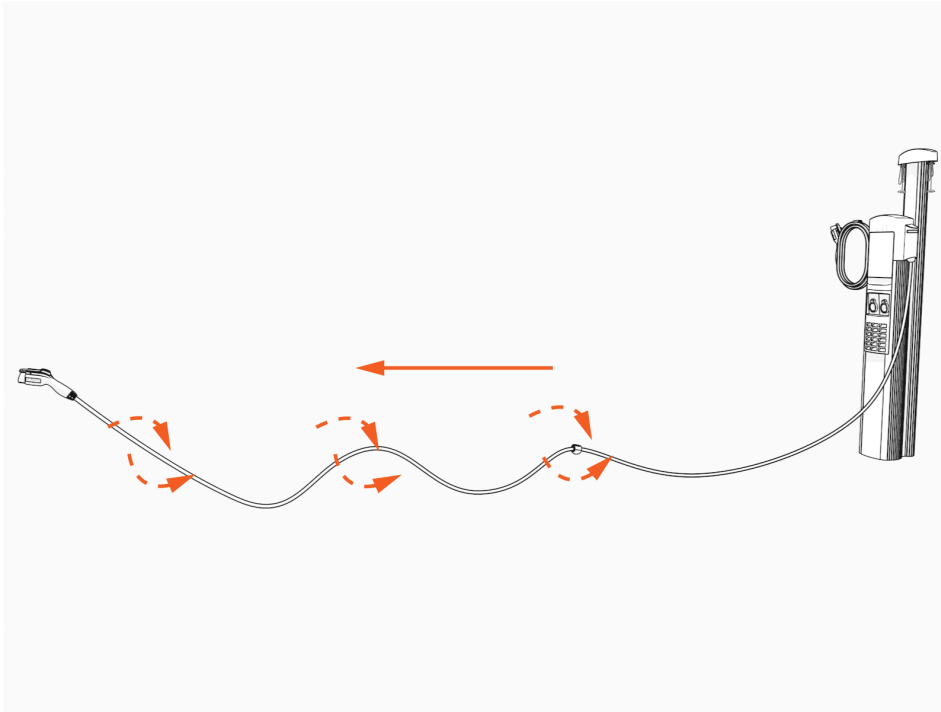

2. Position the charging cable near the base of the station.

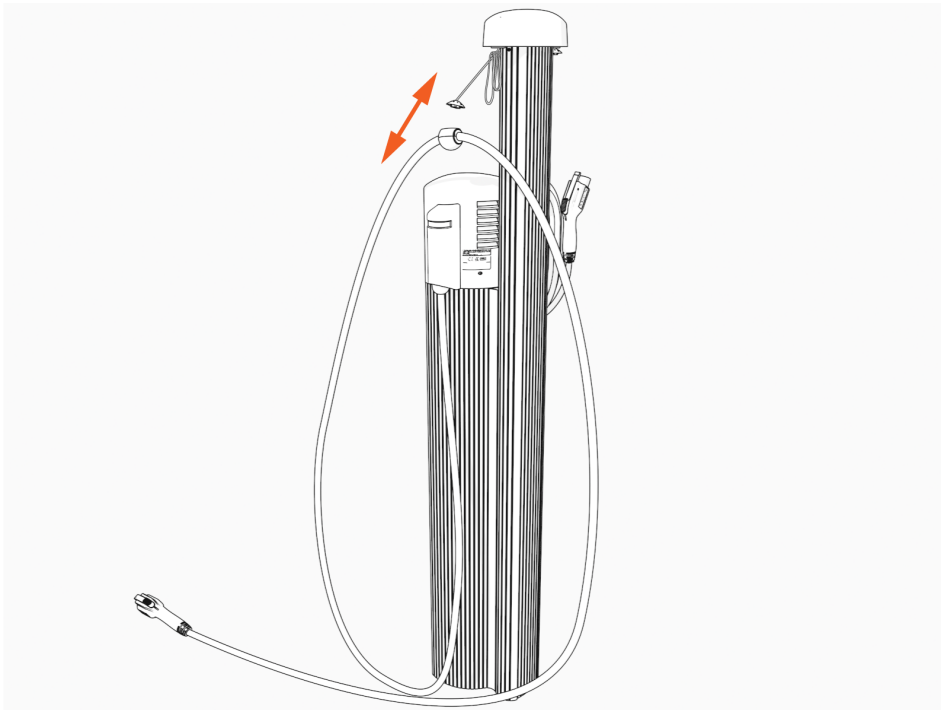

3. Align the knot bearing on each rope to its corresponding mating feature on the cable clamp.

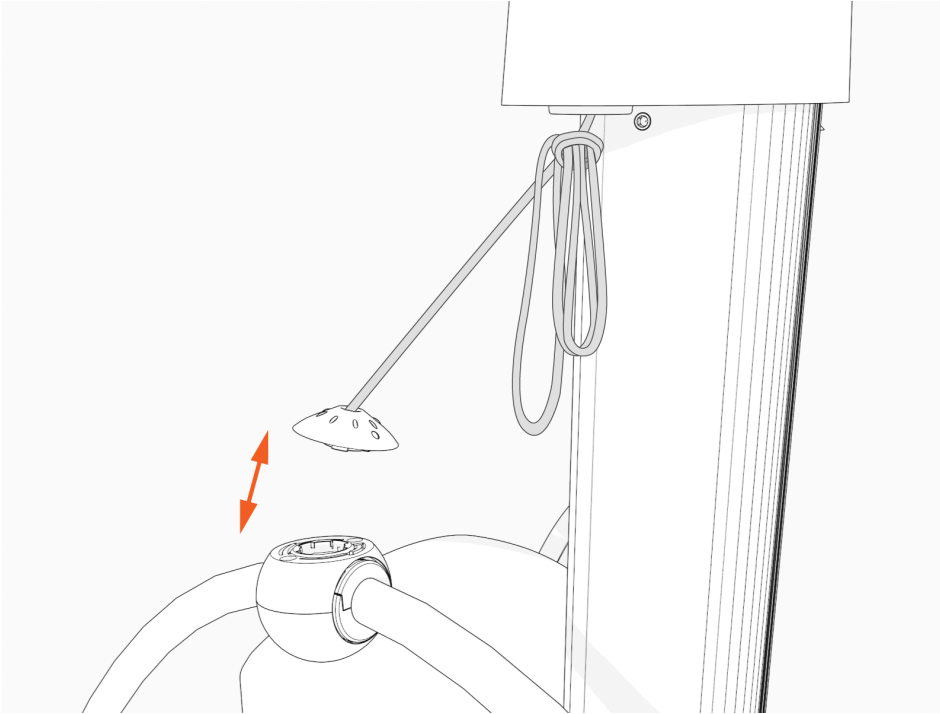

-
4. Using tool provided, turn the knot bearing clockwise approximately 1/4 turn. You may need to push down while turning the knot bearing.



IMPORTANT: Ensure no gap exists between the top cap and the ball.

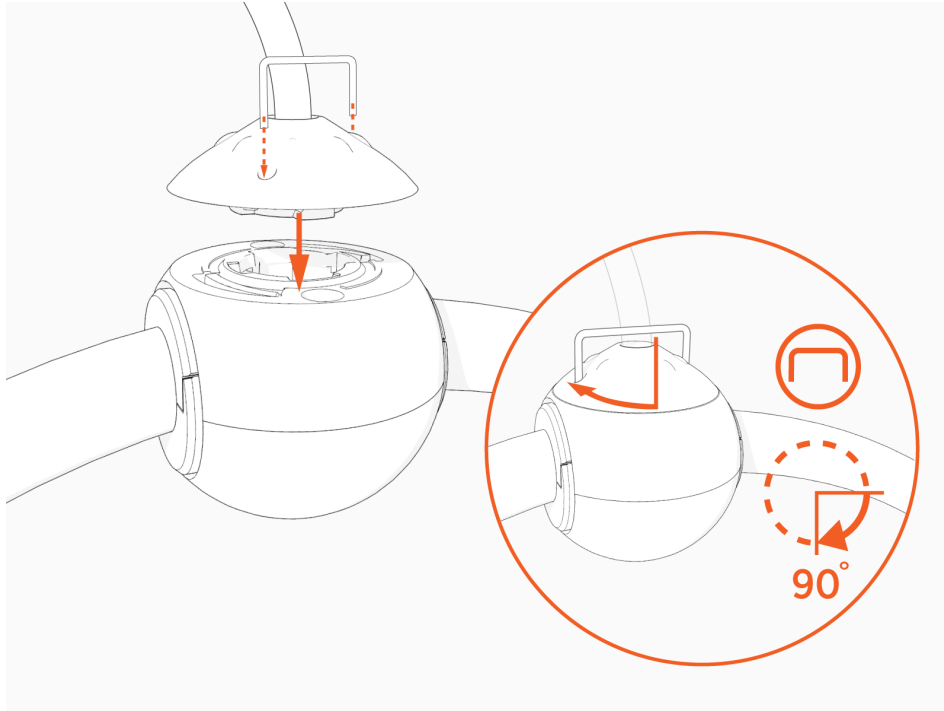

5. Untie the knot near the top of the CMK.

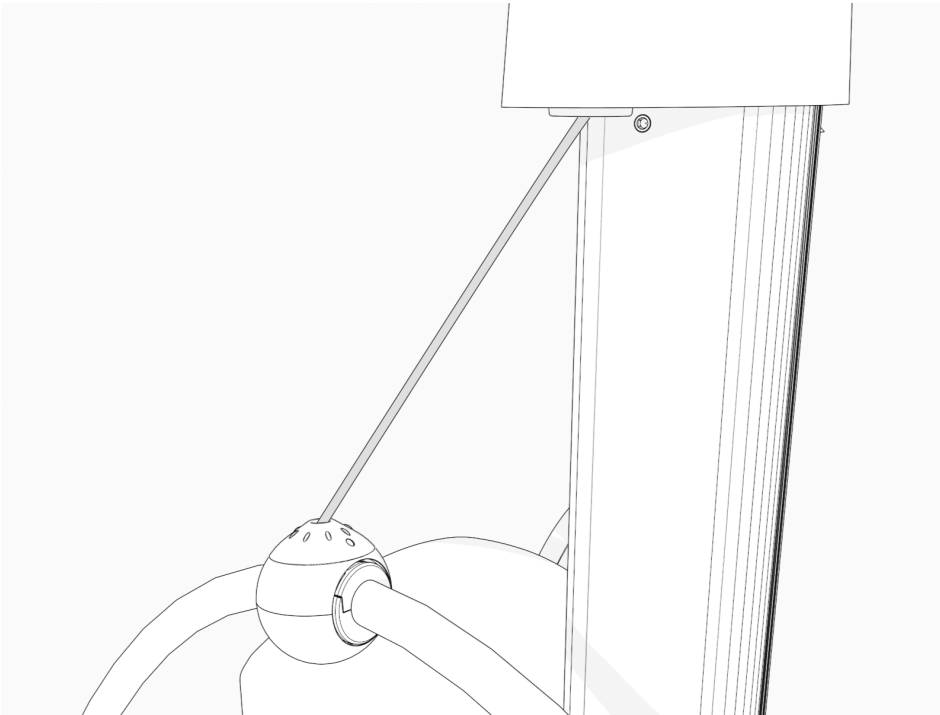
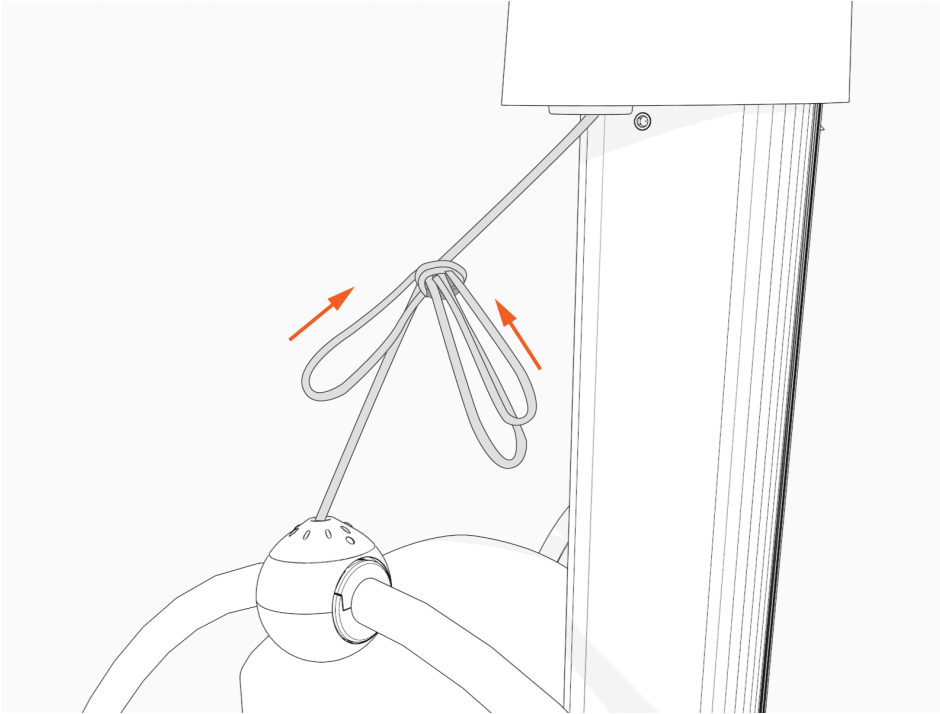

-
6. Check that the charging cable extends and retracts fully and smoothly.

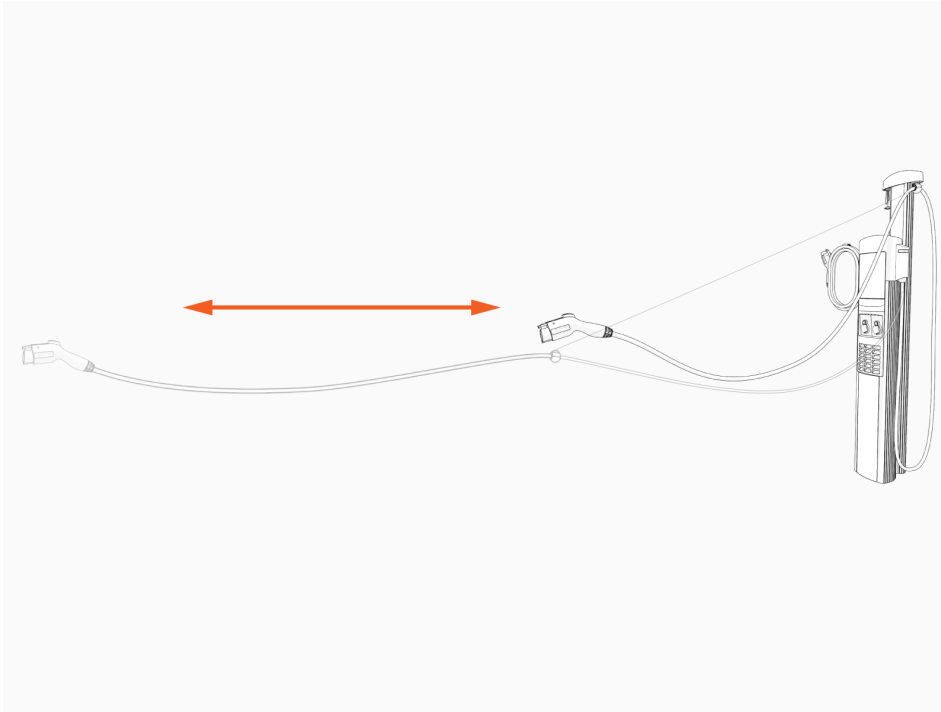

7. Insert the charging cables into their corresponding holsters.

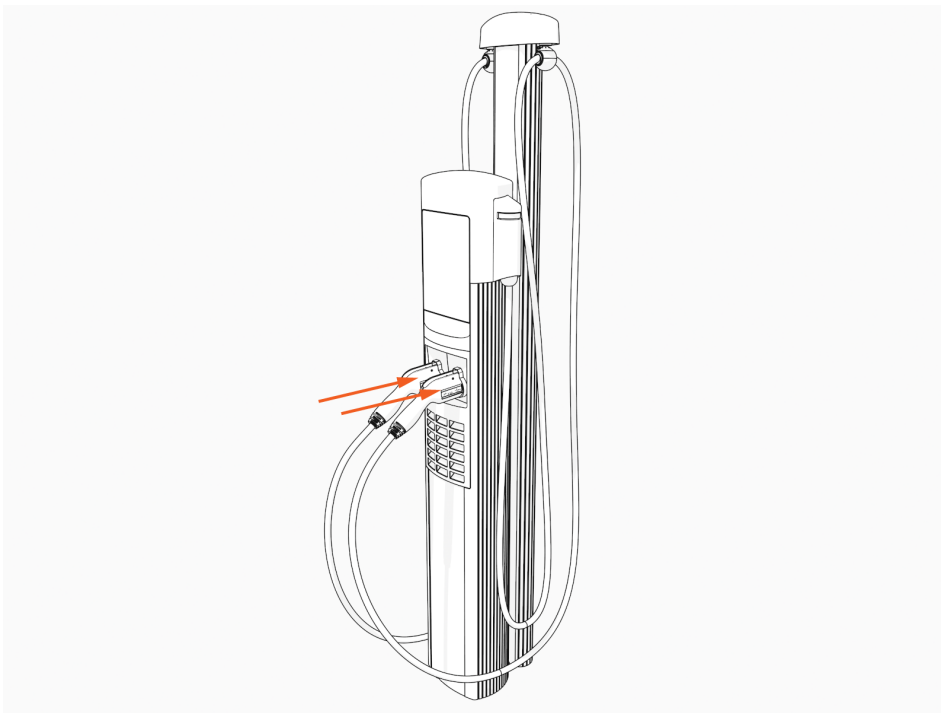

Complete Station Setup 6

To complete the setup, you must have completed the installer training and received your installer login. To complete the next steps, you need:

- Installer login
- Activation label (including the MAC address), if not already applied to top cap
- A smartphone with a camera, QR code scanning (usually built into the camera app), Internet connectivity, and the ChargePoint Installer App

Note: You can also use the Installation Wizard and the Pinpoint Portal (o.chargepoint.com).

- The exact location (to the parking space) where the CP6000 charging station is physically installed

Power Up





1. Power up the station at the breaker panel.

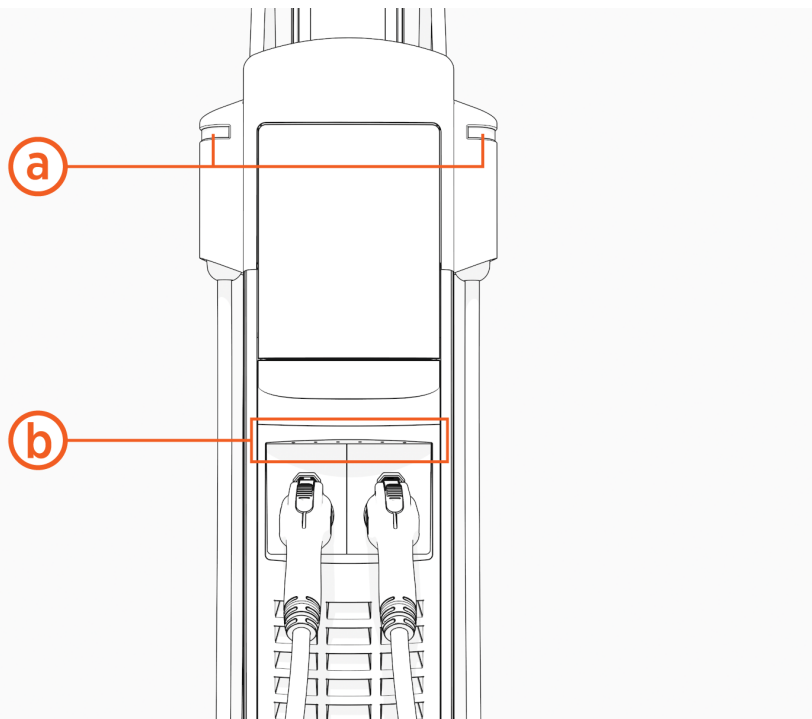

If the station does not power up, turn power back off and check that the head assembly is fully seated into the housing.



2. Check the status lights (a) and the light bar (b). The status lights pulse yellow while the station is booting up.

If any lights are not functioning, or you find other issues, contact ChargePoint Support.



Status Light Color		Operating Definitions
	Light blue	Plugged in and waiting for capacity due to power management and scheduled charging
	Blue, pulsing	Charging a vehicle
	Blue, solid	Charging complete or preparing for vehicle communication after plugging a vehicle in
	Green	Available and ready to charge
	Orange, solid	Online, waiting for a wait-listed vehicle

Status Light Color		Fault Definitions
	Green	Connector fault, one cable fault on a two cable station
	Red	Out-of-service or disabled

Status Light Color		Fault Definitions
	Yellow, pulsing	Plugged in but not authorized, reported as blocked
	White	Offline

Configure and Pinpoint the Station

Use either one of the following two methods to configure and pinpoint the charging station:

- ChargePoint Installation Wizard and Pinpoint Portal
- OR
- ChargePoint Installer App

Installation Wizard and the Pinpoint Portal

Enter the activation password printed on the activation label. (The activation label was on the plastic film on the front lens.)

If your smartphone has a scanning app:

1. Open a QR Code scanning app.
Point the camera at the QR code on the activation sticker.



Your device is automatically redirected to the installer pinpointing page. Confirm that the URL of the page is o.chargepoint.com.



2. Log into the installer site using your installer login. Tap **Log In**.

3. Confirm the MAC address and activation password are automatically entered and correct.
4. Tap **Next**.

If your smartphone does not have a scanning app:

1. Using your smartphone, navigate to o.chargepoint.com.
2. Enter the MAC address and activation password printed on the activation label and tap **Next**.

IMPORTANT: Verify the station serial number before proceeding. It cannot be changed after completing the configuration.

The CP6000 serial number is located behind the flip door on the station. Press along the top edge of the flip door while lifting the bottom edge to open the flip door.

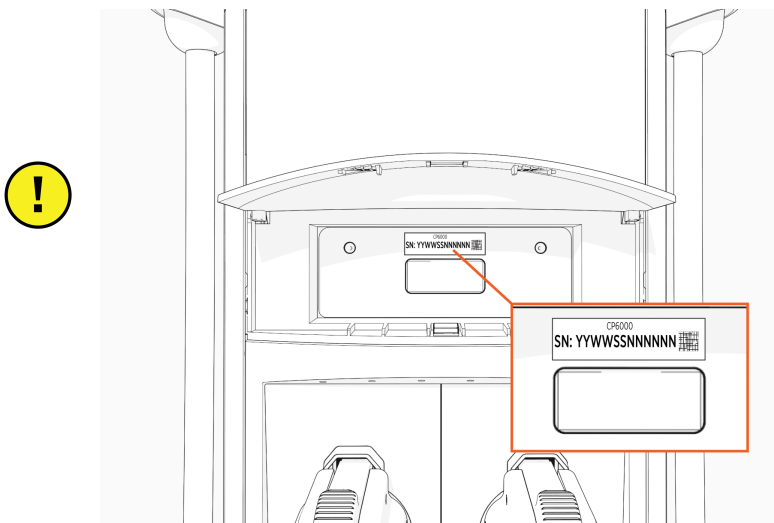

3. Tap the Location Permission button. Your GPS coordinates are required to complete the pinpointing process.
4. Confirm that you are installing a new charging station and tap **Next**.
5. For Make, select the manufacturer.
6. For Model, choose the model shown on the manufacturer type plate. Ensure the image of the equipment shown on the app matches the station onsite.
7. For Station S/N, enter the serial number shown on the manufacturer type plate and tap **Next**.
8. Begin entering the address of the charging station. Select the address from the list of valid addresses and tap **Next**.
9. Drag the map to place the pin in the exact parking space for this charging station and tap **Next**.
10. Enter additional station location details such as Parking lot name, Building name, Floor label, and Parking restrictions, if applicable, then tap **Next**.
11. Add Helpful Information for Drivers, if applicable.
12. Tap **Take Photo** to take an image of the newly labeled charging station and the parking space. Follow onscreen guidance from your camera app to take and use a photo.
13. Touch **Next** to complete the process.

ChargePoint Installer App

Use the ChargePoint Installer App to complete the station setup procedure.

1. If you do not already have the Installer App, scan the QR code to download the app, and sign up.



2. Open the ChargePoint Installer App and log in.
3. Select **Configure**.
4. Confirm you have all required materials to continue activation, and select **Yes**.
5. Follow the prompts in the Installer App.

Start a Charging Session

Once the Installation Wizard is complete, use the app to start a test session. Verify that you can:

- Initiate a charging session
- Unlock the holster and pull out the charge handle
- Plug the handle into the emulator (if available)
- Holster the handle
- Verify that the handle is locked again

Questions?

Go to chargepoint.com/support and find your region's technical support number.

Limited Warranty Information and Disclaimer

The Limited Warranty you received with your charging station is subject to certain exceptions and exclusions. For example, your use of, installation of, or modification to, the ChargePoint® charging station in a manner in which the ChargePoint® charging station is not intended to be used or modified will void the limited warranty. You should review your limited warranty and become familiar with the terms thereof. Other than any such limited warranty, the ChargePoint products are provided "AS IS," and ChargePoint, Inc. and its distributors expressly disclaim all implied warranties, including any warranty of design, merchantability, fitness for a particular purposes and non-infringement, to the maximum extent permitted by law.

Limitation of Liability

CHARGEPOINT IS NOT LIABLE FOR ANY DIRECT, INDIRECT, INCIDENTAL, SPECIAL, PUNITIVE OR CONSEQUENTIAL DAMAGES, INCLUDING WITHOUT LIMITATION LOST PROFITS, LOST BUSINESS, LOST DATA, LOSS OF USE, OR COST OF COVER INCURRED BY YOU ARISING OUT OF OR RELATED TO YOUR PURCHASE OR USE OF, OR INABILITY TO USE, THE CHARGING STATION, UNDER ANY THEORY OF LIABILITY, WHETHER IN AN ACTION IN CONTRACT, STRICT LIABILITY, TORT (INCLUDING NEGLIGENCE) OR OTHER LEGAL OR EQUITABLE THEORY, EVEN IF CHARGEPOINT KNEW OR SHOULD HAVE KNOWN OF THE POSSIBILITY OF SUCH DAMAGES. IN ANY EVENT, THE CUMULATIVE LIABILITY OF CHARGEPOINT FOR ALL CLAIMS WHATSOEVER RELATED TO THE CHARGING STATION WILL NOT EXCEED THE PRICE YOU PAID FOR THE CHARGING STATION. THE LIMITATIONS SET FORTH HEREIN ARE INTENDED TO LIMIT THE LIABILITY OF CHARGEPOINT AND SHALL APPLY NOTWITHSTANDING ANY FAILURE OF ESSENTIAL PURPOSE OF ANY LIMITED REMEDY.

FCC Compliance Statement

This equipment has been tested and found to comply with the limits for a Class B digital device, pursuant to part 15 of the FCC Rules. These limits are designed to provide reasonable protection against harmful interference when the equipment is operated in a residential installation. This equipment generates, uses, and can radiate radio frequency energy and, if not installed and used in accordance with the instruction manual, may cause harmful interference to radio communications.

Important: Changes or modifications to this product not authorized by ChargePoint, inc., could affect the EMC compliance and revoke your authority to operate this product.

Exposure to Radio Frequency Energy: The radiated power output of the 802.11 b/g/n radio and cellular modem (optional) in this device is below the FCC radio frequency exposure limits for uncontrolled equipment. The antenna of this product, used under normal conditions, is at least 20 cm away from the body of the user. This device must not be co-located or operated with any other antenna or transmitter by the manufacturer, subject to the conditions of the FCC Grant.

ISED (formerly Industry Canada)

This device complies with the licence-exempt RSS standard(s) of Innovation, Science and Economic Development Canada (ISED). Operation is subject to the following two conditions: (1) this device may not cause interference, and (2) this device must accept any interference, including interference that may cause undesired operation of the device.

Cet appareil est conforme aux flux RSS exemptés de licence d'Innovation, Sciences et Développement économique Canada (ISDE). L'exploitation est autorisée aux deux conditions suivantes : (1) l'appareil ne doit pas produire de brouillage, et (2) l'utilisateur de l'appareil doit accepter.

Radiation Exposure Statement: This equipment complies with the IC RSS-102 radiation exposure limits set forth for an uncontrolled environment. This equipment should be installed and operated with a minimum distance of 20 cm between the radiator and your body.

Énoncé d'exposition aux rayonnements: Cet équipement est conforme aux limites d'exposition aux rayonnements ioniques RSS-102 Pour un environnement incontrôlé. Cet équipement doit être installé et utilisé avec un Distance minimale de 20 cm entre le radiateur et votre corps.

FCC/IC Compliance Labels

Visit chargepoint.com/labels.



chargepoint.com/support

75-001449-01 r2

CP6000

Networked Charging Station

Site Design Guide

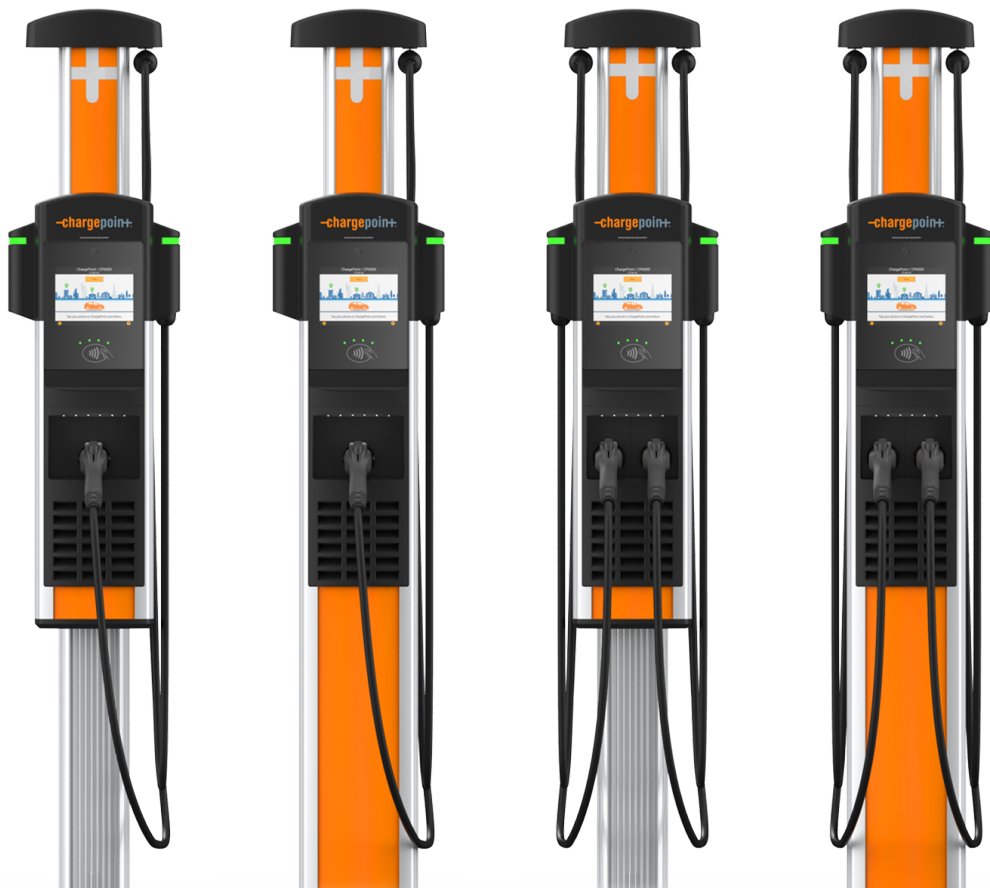

IMPORTANT SAFETY INSTRUCTIONS

SAVE THESE INSTRUCTIONS

WARNING:

- 
1. **Read and follow all warnings and instructions before servicing, installing, or operating the ChargePoint® charging station.** Install and operate only as instructed. Failure to do so may lead to death, injury, or property damage, and will void the Limited Warranty.
 2. **Only use licensed professionals to install your ChargePoint charging station and adhere to all national and local building codes and standards.** Before installing the ChargePoint charging station, consult with a licensed contractor, such as a licensed electrician, and use a trained installation expert to ensure compliance with local building and electrical codes and standards, climate conditions, safety standards, and all applicable codes and ordinances. Inspect the charging station for proper installation before use.
 3. **Always ground the ChargePoint charging station.** Failure to ground the charging station can lead to risk of electrocution or fire. The charging station must be connected to a grounded, metal, permanent wiring system, or an equipment grounding conductor shall be run with circuit conductors and connected to the equipment grounding terminal or lead on the Electric Vehicle Supply Equipment (EVSE). Connections to the EVSE shall comply with all applicable codes and ordinances.
 4. **Install the ChargePoint charging station on a concrete pad using a ChargePoint-approved method.** Failure to install on a surface that can support the full weight of the charging station can result in death, personal injury, or property damage. Inspect the charging station for proper installation before use.
 5. **This charging station is not suitable for use in Class 1 hazardous locations, such as near flammable, explosive, or combustible vapors or gases.**
 6. **Supervise children near this device.**
 7. **Do not put fingers into the electric vehicle connector.**
 8. **Do not use this product if any cable is frayed, has broken insulation, or shows any other signs of damage.**
 9. **Do not use this product if the enclosure or the electric vehicle connector is broken, cracked, open, or shows any other signs of damage.**
 10. **Use only copper conductor wire rated for 90 °C (194 °F).**
-



IMPORTANT: Under no circumstances will compliance with the information in a ChargePoint guide such as this one relieve the user of the responsibility to comply with all applicable codes and safety standards. This document describes approved procedures. If it is not possible to perform the procedures as indicated, contact ChargePoint. **ChargePoint is not responsible for any damages that may result from custom installations or procedures not described in this document or that fail to adhere to ChargePoint recommendations.**

Product Disposal

Do not dispose of as part of unsorted domestic waste. Inquire with local authorities regarding proper disposal. Product materials are recyclable as marked.

Document Accuracy

The specifications and other information in this document were verified to be accurate and complete at the time of its publication. However, due to ongoing product improvement, this information is subject to change at any time without prior notice. For the latest information, see our documentation online at chargepoint.com/guides.

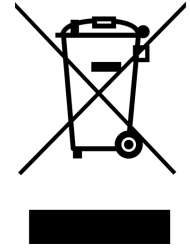

Copyright and Trademarks

©2013-2024 ChargePoint, Inc. All rights reserved. This material is protected by the copyright laws of the United States and other countries. It may not be modified, reproduced, or distributed without the prior, express written consent of ChargePoint, Inc. ChargePoint and the ChargePoint logo are trademarks of ChargePoint, Inc., registered in the United States and other countries, and cannot be used without the prior written consent of ChargePoint.

Symbols

This guide and product use the following symbols:



DANGER: Risk of electric shock



WARNING: Risk of personal harm or death



CAUTION: Risk of equipment or property damage



IMPORTANT: Crucial step for installation success



Read the manual for instructions



Ground/protective earth

Illustrations Used in This Document

The illustrations used in this document are for demonstration purposes only and may not be an exact representation of the product. However, unless otherwise specified, the underlying instructions are accurate for the product.

Contents

Important Safety Instructions	iii
1 Site Design Guidelines	1
Initial Site Guidelines	2
Electrical Requirements	2
Charging Station Placement	3
2 Civil and Mechanical Design	5
Component Dimensions and Weights	5
Mounting Specifications - Pedestal Mount Stations	8
Mounting Specifications - Wall Mount Stations	15
Drainage	16
Clearances	16
Accessibility	16
Signage	16
3 Electrical Design	17
General Wiring Considerations	17
Electrical Supply Requirements	18
Grounding Requirements	19
4 Connectivity	23
5 Pedestal Mount Concrete Preparation	27
Concrete Mounting Template	27
Tools and Materials	30
Installation into New Concrete	30
Install on Existing Concrete	34

Site Design Guidelines 1

This document describes how to design a project site for the ChargePoint® CP6000 networked charging station for electric vehicles. This includes guidelines and best practices for electrical infrastructure and capacity planning, construction, and concrete work required prior to installation of charging stations and cellular signal requirements.

Note: CP6000 charging stations are available in several configurations. The images in this guide might not match your station exactly; however, the information is applicable unless otherwise noted.



IMPORTANT: Ensure the installation complies with all applicable codes and ordinances.

Access ChargePoint documents at chargepoint.com/guides.

Document	Content	Primary Audiences
Datasheet	Full station specifications	Site designer, installer, and station owner
Site Design Guide	Civil, mechanical, and electrical guidelines to scope and construct the site	Site designer or engineer of record
Concrete Mounting Template Guide	Instructions to embed the charging station template in a concrete pad with anchor bolts and conduit placement	Site construction contractor
Construction Signoff Form	Checklists used by contractors to ensure the site is correctly completed and ready for product installation	Site construction contractor
Installation Guide	Anchoring, wiring, and powering on	Installer
Operation and Maintenance Guide	Operation and preventive maintenance information	Station owner, facility manager, and technician
Service Guide	Component replacement procedures, including optional components	Service technician
Declaration of Conformity	Statement of conformity with directives	Purchasers and public

Initial Site Guidelines

Designing electrical infrastructure to support current and future EV charging demand can help avoid costly upgrades later as EV adoption grows.

Complete an on-site evaluation to determine conduit and wiring requirements from the panel to the proposed parking spaces, as well as to measure cellular signal levels and identify suitable locations for any necessary cellular signal booster equipment.

If you have pre-existing infrastructure or are using your own preferred electrical contractor to prepare your site, a Construction Signoff Form by a ChargePoint Operations and Maintenance (O&M) partner is required to certify compliance with electrical code, and to ensure everything was prepared to ChargePoint specifications.

IMPORTANT: You must be a licensed electrician and complete online training to become a ChargePoint certified installer. If you do not complete training, you cannot access the ChargePoint network to complete installation.



Find online training at: chargepoint.com/installers

If the charging station is not installed by a ChargePoint certified installer, using a ChargePoint approved method, it is not covered under warranty and ChargePoint is not responsible for any malfunctions.

Electrical Requirements

At a minimum, each Level 2 charging station, either single or dual port, requires the following:

- A dedicated single phase electrical circuit from 40 A to 80 A
- A new circuit breaker at the electrical panel
- Conductor wiring and circuit protection sized in accordance with all applicable codes

Consequently, CP6000 charging station with two charge ports typically requires two power input circuits, one circuit per port. There may be situations where both ports share a main single circuit. If power capacity is limited at a site or to reduce costs for electrical infrastructure, consider ChargePoint Power Management options for power sharing at the circuit level, panel level, transformer, or site level.



IMPORTANT: Always check local codes to ensure compliance. You may need to adjust these instructions to comply with codes that apply at your installation location.

Additional Electrical Considerations

- CP6000 charging stations are AC electrical vehicle (EV) supply equipment and are permanently connected to AC networks.
- Evaluate existing electrical infrastructure to determine if the existing utility service and electrical panel capacity is sufficient.

- Ensure appropriate electrical wiring, over current circuit protection, and metering, if required, is in place.
- Identify costs for any necessary upgrades and/or a new dedicated electrical panel.
- ChargePoint recommends using a licensed electrician to evaluate available capacity and identify any upgrades that may be required.
- If a dedicated EV electrical panel is required, choose a panel location in close proximity to the charging stations.
- Determine raceway or conduit runs for electrical wiring from the electrical panel.

Charging Station Placement

To help minimize costs, choose station locations that are as close as possible to the available electrical infrastructure. Selecting these types of locations helps minimize long conduit and wire runs, as well as any trenching work.



WARNING: The ChargePoint charging station must be installed on a level concrete base or a flat wall rated for the weight of the station. Asphalt cannot support the full weight of the station. Failure to install the station on a suitable surface may cause the station to tip over, resulting in death, personal injury, or property damage.

Layout Considerations

- Identify station locations for EV charging spots.
- CP6000 charging stations can be installed either indoors or outdoors.
- They can be mounted on walls or in the ground (pedestal mount).
- CP6000 charging stations do not have an integrated active ventilation system.
- To help minimize costs, choose station locations that are as close as possible to the available electrical infrastructure.
- Consider locations where it will be easy to add future stations.
- Consider how easily drivers can find the stations they need to access.
- Identify suitable locations with smooth, plumb surfaces for wall mount stations or suitable floor surfaces for pedestal mount stations.
- Consider a layout to minimize electrical infrastructure costs to all proposed EV parking spaces.
- Avoid or minimize trenching requirements.
- Comply with regional accessibility laws, regulations, and ordinances. The CP6000 charging station must not block ramps or pathways and the height of the interactive display cannot exceed the maximum height as dictated by local laws.
- For stall parking, ChargePoint recommends using perpendicular parking stalls to better accommodate EVs with front and rear charge ports.

-
- Use dual-port pedestal mount stations where possible in open areas for adjacent parking or adjoining parking spaces.
 - Consider protective bollards and wheel blocks where appropriate, especially for open tandem parking spaces.
 - If the charging station has a camera, orient the camera towards the parking space.
 - Use professional cellular test equipment to measure cellular signal levels to ensure adequate cellular coverage at the station installation location. To ensure adequate signal strength in underground or enclosed parking structures, cellular repeaters may be required. Use an indoor antenna located near EV parking spaces and an outdoor antenna typically located at the garage entrance ceiling or on the rooftop where cellular signals are best. See [Connectivity](#) for more details.
 - When the charging stations cannot be placed close enough to the source of power to avoid undesirable line losses, consider increasing the size of the conductors. When the circuit conductors must be larger than 1/0 AWG, you must add a disconnect immediately adjacent to the station and terminate the upsized conductor at the line side lug of the disconnect. Then, connect a short length of 1/0 AWG conductor to the load side lug of the disconnect and the station. Adding disconnects close to the stations is also helpful when the circuit breakers are relatively far away.

Plan for the Future

Consider current EV charging needs and also potential future needs as EV adoption grows.

- Consider running raceway or conduit to all planned EV parking spots and pulling electrical wiring from the panel to meet current needs.
- Consider installing a dedicated electrical panel for EV charging and leveraging ChargePoint Power Management. This efficiently uses available power at a site to support more EV charging ports than would otherwise be possible.

Civil and Mechanical Design **2**

Use the guidance below to design the civil and mechanical aspects of the site.

Each charging station can be installed attached to a wall or on a concrete pedestal with a Cable Management Kit (CMK). The pedestal can be mounted on a newly poured pad or an existing concrete surface.

Component Dimensions and Weights

Each CP6000 charging station can be mounted on a pedestal or on a wall with a Cable Management Kit (CMK). The station is a vertical enclosure with the weights and dimensions shown below.

Station Configuration	Approximate Weight
Single port, wall	62 kg (136 lb)
Dual port, wall	68 kg (150 lb)
Single port, pedestal	71 kg (155 lb)
Dual port, pedestal	76 kg (168 lb)

Pedestal Mount With CMK

Note: Images are not to scale. Measurements appear in metric units (mm), followed by imperial equivalents (inches).

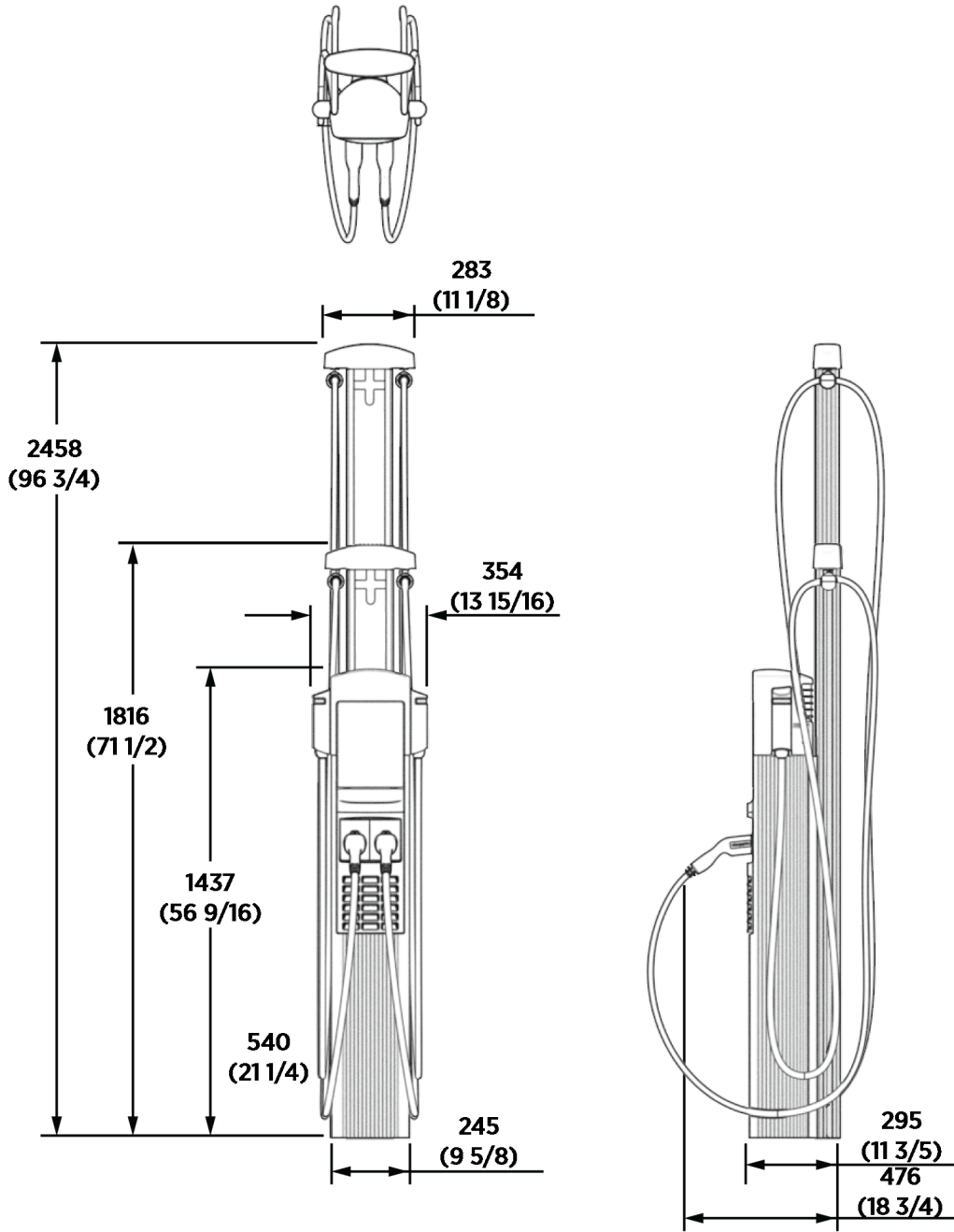

Wall Mount With CMK

Note: Images are not to scale. Measurements appear in metric units (mm), followed by imperial equivalents (inches).

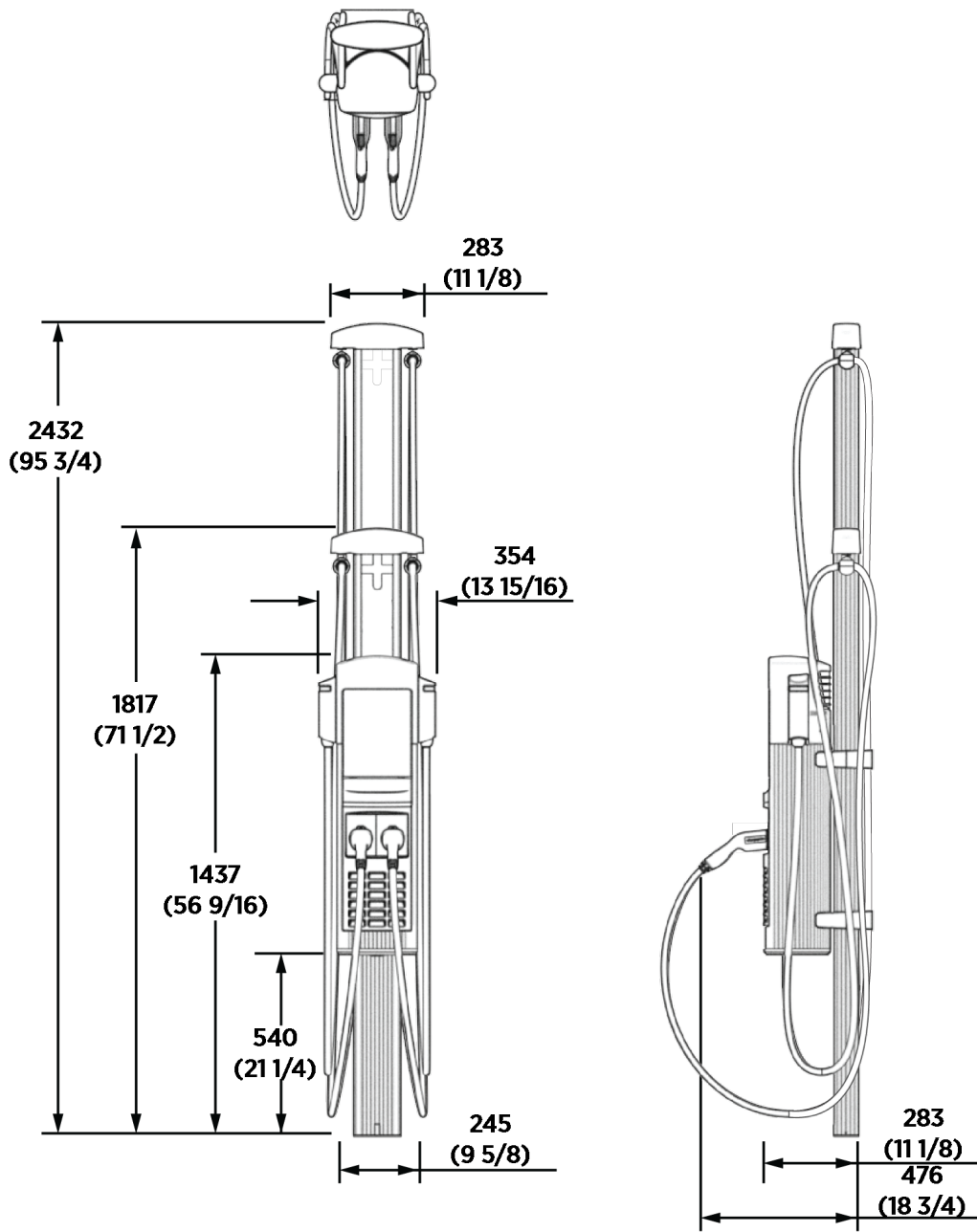

Mounting Specifications - Pedestal Mount Stations



IMPORTANT: Use a ChargePoint Concrete Mounting Template (CMT) when installing a new pedestal mount charging station or replacing an existing non-ChargePoint pedestal mount station. You do not need a CMT if you are installing a wall mount charging station or replacing an existing ChargePoint station.

The concrete pad must either be designed to be site-specific or must meet these specifications:

- Must not be installed in asphalt
- Mounting surface must be smooth
- Mounting surface cannot exceed a slope of 6 mm per 300 mm (0.25 in per ft)
- The concrete base must measure at least 600 mm (2 ft) on all sides
- Epoxy anchors can be used (installations in existing concrete)
- No expanding bolts are used
- Consult a civil engineer to ensure sufficient volume and strength of concrete; (installations in existing concrete)



IMPORTANT: If the existing pad does not meet the specifications above, a structural engineer must inspect and approve the pad for CP6000 charging station dimensions and weight.

Pedestal Base Designs

There are three basic pedestal base designs:

- In front of a curb **(a)** - Does not obstruct a pedestrian pathway or disturb landscaping.
 900 mm (3 ft) on each side **(b)**
 Area: 0.42 m² (4.5 ft²)
 Volume: 0.26 m³ (9 ft³)

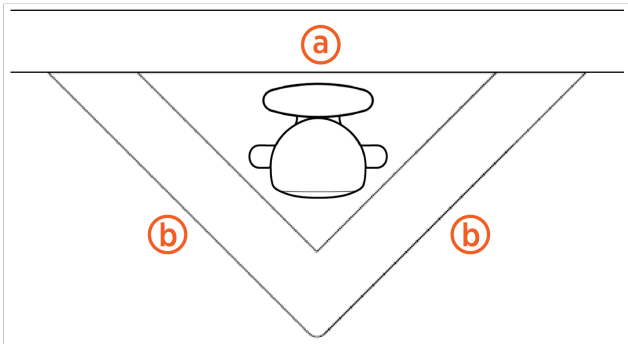

- Behind a curb **(a)** in a planter or berm
 600 mm (2 ft) on each side
 Area: 0.37 m² (4 ft²)
 Volume: 0.23 m³ (8 ft³)

Note: Use a retaining wall as needed to prevent dirt from accumulating on the pad.

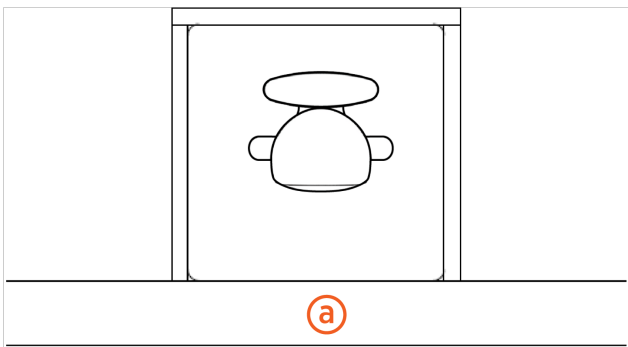

-
- Two stations back to back, centered between four spaces 900 mm (3 ft) on each side
Area: 0.84 m² (9 ft²)
Volume: 0.51 m³ (18 ft³)

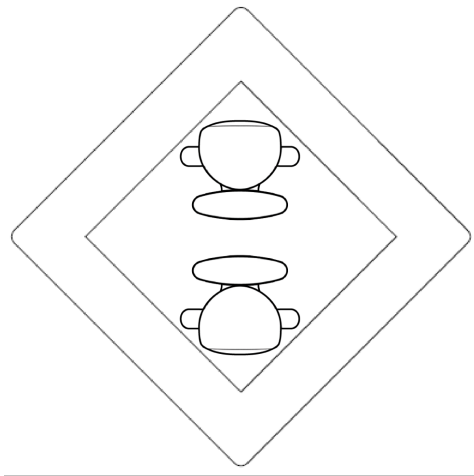

Pedestal Configurations for Different Parking Arrangements

The pedestal base design can be configured in a variety of ways to serve different parking arrangements. Ensure a sufficient volume of concrete to provide anchoring for the charging station.

Note: CP6000 charging stations are available in several configurations. The images in this guide might not match your station exactly; however, the information is applicable unless otherwise noted.

- Place the station against the curb between spaces with wheel stops 900 mm (3 ft) from the front of each stall. The base of the charging station can be flush with the parking spaces or at curb level.

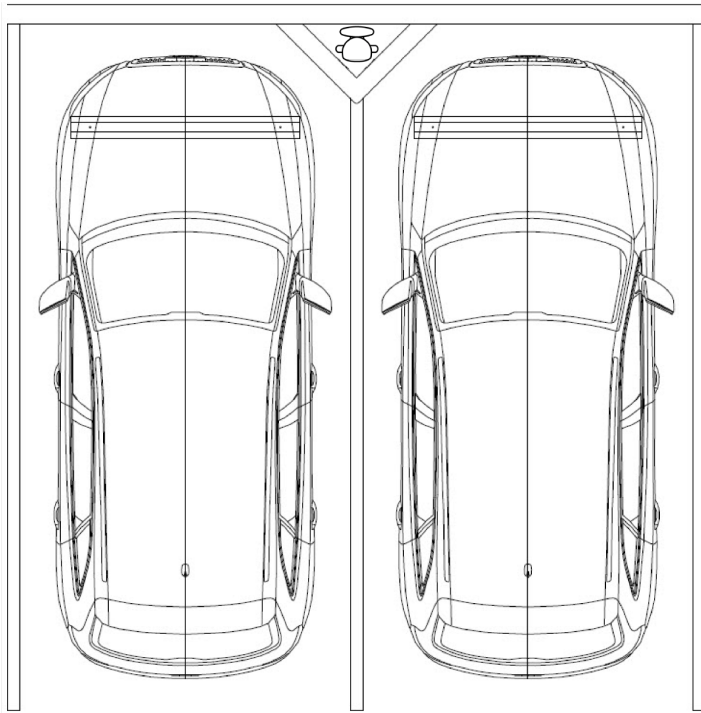

- Place the station in a planter or berm between spaces with wheel stops 900 mm (3 ft) from the front of each stall or the curb **(a)**.

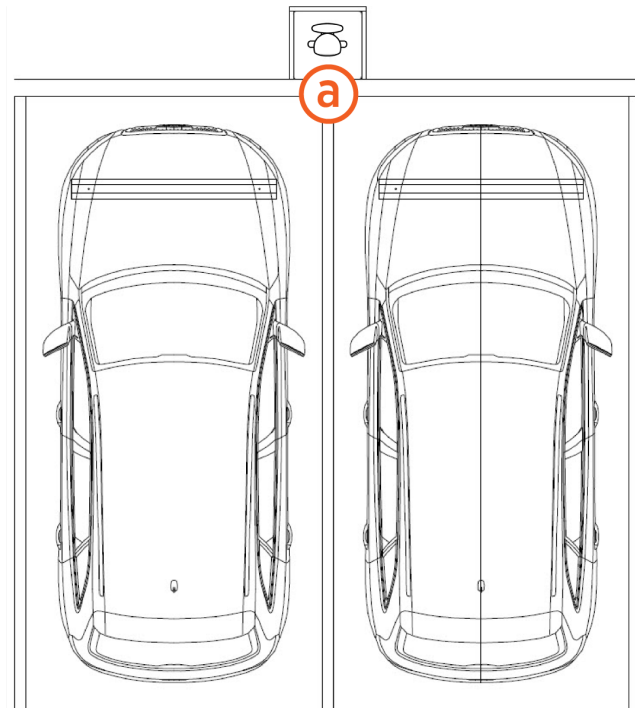

- Place two stations back to back centered on four spaces with wheel stops 900 mm (3 ft) from the front of each stall. The base of the charging station can be flush with the parking spaces or at curb level.

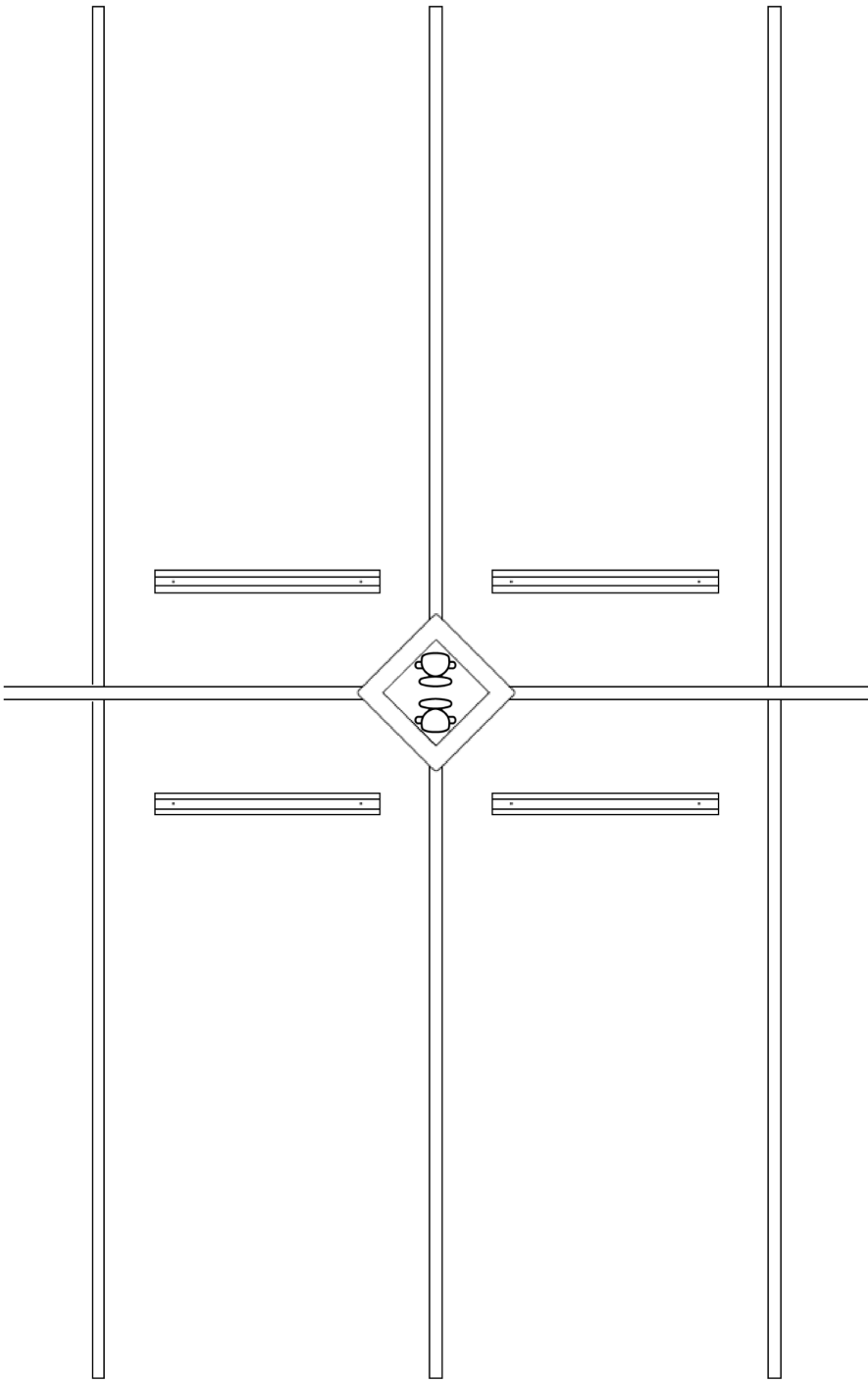

- When placing a dual holster station centered on the right space, the charging cables can reach two vehicles. Place a wheel stop 1220 mm (4 ft) **(a)** from the center of the charging station.

Note the following details for this arrangement:

- The arc shows the usable reach of the two charging cable lengths available: 5.5 m (18 ft) **(b)** and 7 m (23 ft) **(c)**.
- The 7 m (23 ft) cord option is recommended for this configuration.
- The base of the charging station can be flush with the parking spaces or at curb level.
- Be sure to install 'EV Charging Station' signs on both spaces.

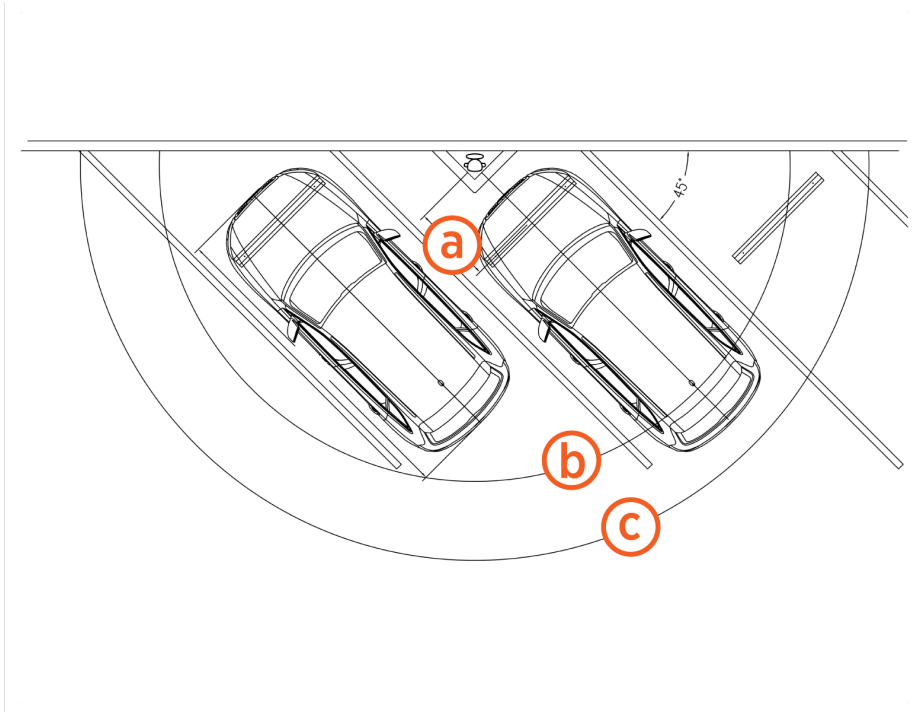

- Place a dual holster station centered between two parallel parking spaces, each 6 m (20 ft) long. Place the station **(a)** 450 mm (18 in) from the curb. A 7 m (23 ft) charging cable is recommended.

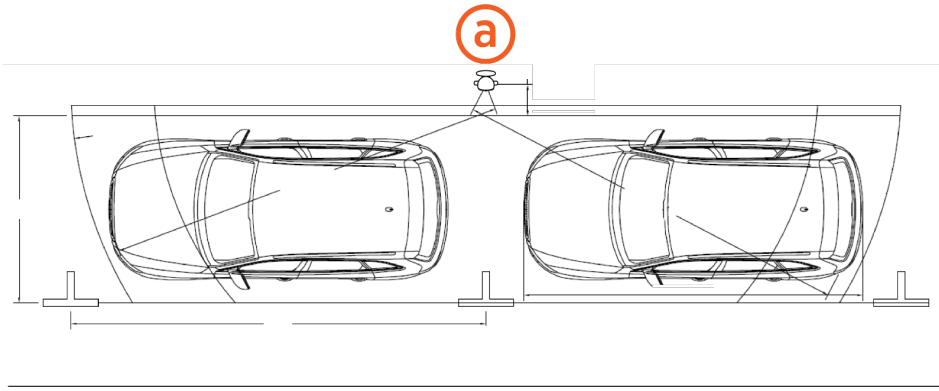

- Place a single holster station for a single parallel parking space 6 m (20 ft) long. Place the station **(a)** 450 mm (18 in) from the curb, and 1.8 m (6 ft) from the front of the parking space **(b)** This allows the cord to reach any part of the vehicle without blocking the curb side doors.

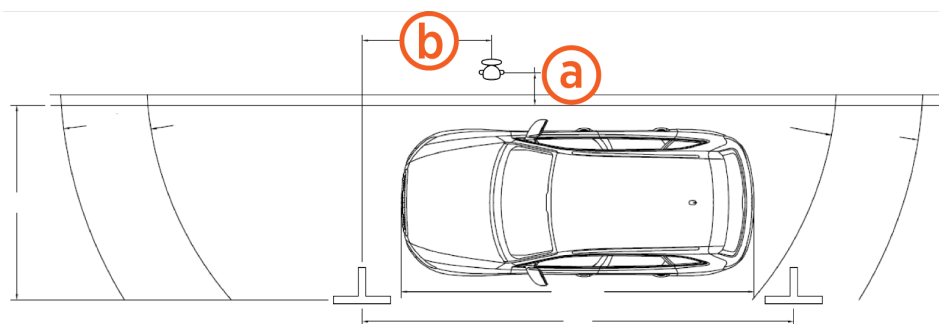

Mounting Specifications - Wall Mount Stations

For wall mounted stations:

- The wall must be smooth, stable, and plumb.
- The minimum height of the wall must be 1160 mm (45.7 in) above a finished floor.
- Place wheel stops 900 mm (3 ft) **(a)** from the wall.
- The arcs show the usable reach of two charging cable lengths available, 5.5 m (18 ft) **(b)** and 7 m (23 ft) **(c)**.

Note: Ensure the space between the wall and the charging station is clear and free of debris.

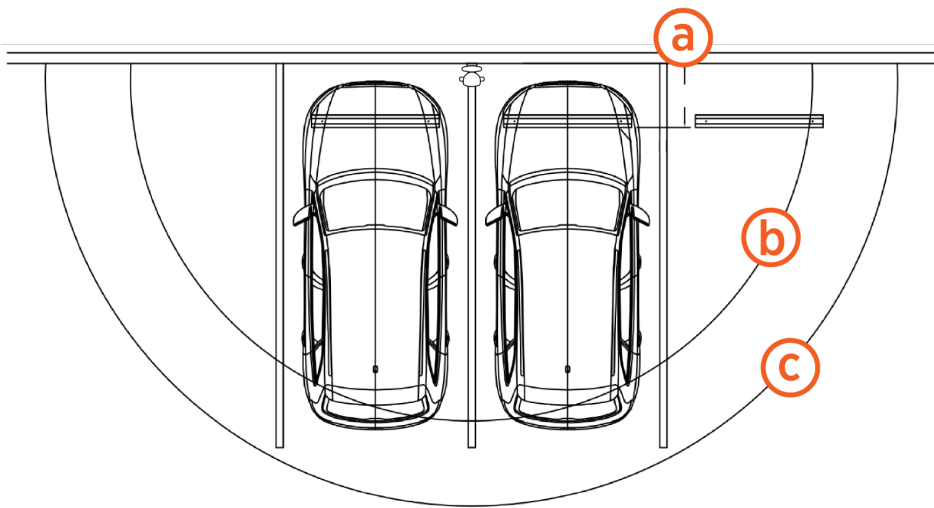

IMPORTANT: Ensure the wall supports the station. If mounting to a hollow wall, bridge at least two studs using a 41 mm (1 5/8 in) channel strut.



WARNING: If not installed correctly, the ChargePoint charging station may pose a fall hazard, leading to death, personal injury, or property damage. Always use the provided Concrete Mounting Template shown preinstalled here, or a ChargePoint-approved surface mounting solution, to install the ChargePoint charging station. Always install in accordance with applicable codes and standards using licensed professionals. Non approved installation methods are performed at the risk of the contractor and void the Limited One-Year Parts Exchange Warranty.

Drainage

Ensure any slopes, walls, or fencing at the site do not trap water around the charging station installation site. The system is only built to withstand water to the height of the conduit stub-up.



WARNING: Exposing the ChargePoint charging station to water above the height of the conduit stub-up could create an electrocution, shock, or fire hazard. Cut power to the charging station if it has been exposed to standing water and contact ChargePoint before the charging station is powered on.

Clearances

For pedestal installations, the conduit stub-up must be a minimum of 230 mm (9 in) from any obstructions to the rear. This includes other charging stations. Check applicable codes for any additional clearance requirements.

Accessibility

Comply with regional accessibility laws, regulations, and ordinances. The CP6000 charging station must not block ramps or pathways and the height of the interactive display cannot exceed the maximum height as dictated by local laws.

Signage

Refer to local and regional code to design the following elements for the site:

- Any required re-stripping of parking spaces
- EV or Accessible EV signs
- EV or Accessible EV paint markings on and around the parking spaces

Electrical Design 3

The CP6000 charging stations are available with a maximum amperage of either 50 A or 80 A.

If the charging station allows a maximum of 50 A, Power Select current options include 16 A, 24 A, 32 A, 40 A, 48 A, and 50 A.

If the charging station allows a maximum of 80 A, Power Select current options include 16 A, 24 A, 32 A, 40 A, 48 A, 50 A, 56 A, 64 A, 72 A, and 80 A.

Power Share allows a dual-port station to share power from a single circuit across two ports, adjusting power depending on whether one or both are charging. Standard wiring uses an independent circuit for each port. Power Share can be used in combination with Power Select.

Refer the CP6000 datasheet at chargepoint.com/guides for information about the following:

- Electrical input
- Electrical output
- Mounting and functional interfaces
- Safety and connectivity features
- Safety and operational ratings

General Wiring Considerations

Ensure that the installation location is equipped with service wiring that supports the charging station's power requirements.

Conduit and wire size are determined based on the length of runs from the electrical panel to the station location. Service wiring must be run through conduit to comply with local electrical codes. Consult national and local codes or a project engineer to determine the grade, quality, and size of the conduit or cable.

Attach the conduit with a listed adapter. Use a sealing method that meets all applicable code requirements.

The CP6000 Concrete Mount Kit accommodates service wiring through the flare, conduit, or locally appropriate wiring method. Visit [Pedestal Mount Concrete Preparation](#) for more information.

Note: All wiring and conduit is supplied by the contractor unless otherwise indicated.

For full product specifications, refer to the CP6000 Datasheet.

Wall Mount Considerations

- CP6000 wall mounted charging stations use surface mount wiring.
- When pulling electrical wiring for wall mount stations, the conduit and wire must be brought to the location where the stations will be mounted. Flex conduit is typically used to bring the wire to the station. Wiring is brought in through knock outs in the bottom of the charging station.

Pedestal Mount Considerations

- CP6000 pedestal mounted charging stations typically require service wiring installed underground to enter through the bottom of the station.
- When pulling electrical wiring for CP6000 pedestal mount, ensure at least 1.5 m (5 ft) of wire remains above grade.

Conduit

The outside diameter of conduit must not exceed the sizes called out in the pedestal mounting template: 95 mm (3.74 in). Conduit stub-ups must measure between 152 mm (6 in) and 590 mm (23.25 in) above grade.

Conduit stub-ups must not extend higher than 600 mm above ground level.

Electrical Supply Requirements

Wiring must be sized in accordance with all applicable codes for continuous load devices. The main standard for cable size is based on IEC 60364-5-52:2009 and IEC 60364-5-54:2011. The terminal block accepts stranded or solid conductors up to 1/0 AWG (50 mm²). The appropriate size depends upon the distance between the electrical panel and the charging station installation site and the maximum current in the circuit.

When planning multiple EV charging stations, it is best practice to separate non-continuous from continuous loads, with all branch circuits for EV charging on a dedicated electrical panel assembly with adequate circuit breakers. When sizing new electrical panels dedicated for EV charging, all branch circuits must support continuous load.

CP6000 charging stations are designed for connection to and operation on rated voltages of 208 V or 240 V (phase to phase) at 60 Hz. Source must have neutral bonded to ground to establish 120 V phase to ground.



CAUTION: CP6000 charging station is rated Over-voltage Category III and includes surge protection for absorbing transient over voltages. CP6000 charging stations are tested to IEC 61000-4-5 (4 kV) standards. In countries where extra Surge Protection Device protection is required, check the national codes for categorization and installation of the equipment.

CAUTION: Use copper conductors only.

Use new circuit breakers only.



Port Capacity	Breaker Rating
80 A /port	100 A breaker per port
48 A/port	60 A breaker per port
40 A/port	50 A breaker per port

Ensure all power and ground connections (especially those at the breaker) are clean, tight, and torqued to specification. Remove all oxide from all conductors and terminals before connecting wiring.

Be aware of these requirements before installing the charging station:

- CP6000 charging stations comply with Class B.
- The CP6000 is Class I grounded equipment and must be grounded.

Consult your electricity grid operator regarding requirements for local regulations. Depending on the desired rated power, the installation of the charging station may require registration with and approval by your electricity grid operator.

Grounding Requirements

CP6000 charging stations must be connected to a grounded, metal, permanent wiring system. An equipment-grounding conductor must be run with circuit conductors and connected to an equipment-grounding terminal on the charging station.

A grounding conductor that complies with applicable codes must be grounded to earth at the service equipment or, when supplied by a separate system, at the supply transformer, or may be grounded to an earth electrode. Ensure the grounding conductor complies with all applicable codes.

Connect To These Systems

- 120/240 V AC, 1Ø Bonded Neutral
Station is connected to L1 and L2
Neutral is not used

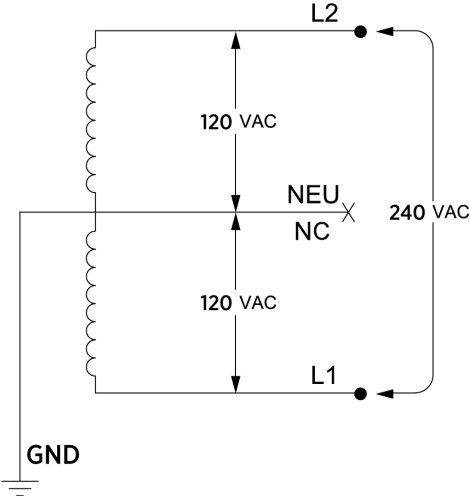

- 120/208 V AC, 3Ø Wye Bonded Neutral
Station may be connected to any two lines
Neutral is not used

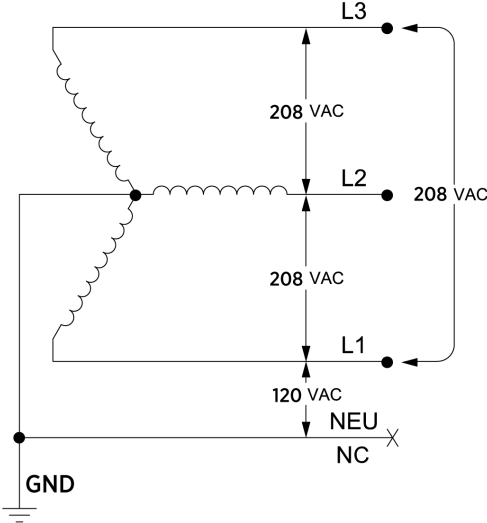

Do Not Connect to These Systems

- 208 V AC 3Ø Wye, ungrounded
Floating Neutral
Voltage of either line to ground is undetermined
Neutral is not grounded

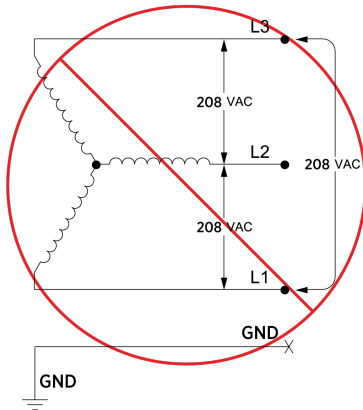

- 120/240 V AC 3Ø Delta, corner-grounded
Voltage of any line is not 120 V nominal relative to ground
- Any system where the center point of the AC power source is not grounded.

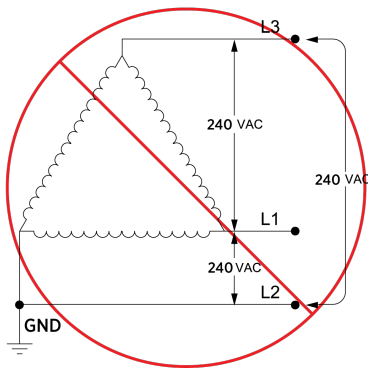

Connectivity 4

A consistently strong cellular signal is needed before installers can activate the vehicle charging station. Weak or sporadic signal can affect crucial aspects of the charging station, including:

- Accuracy in reporting
- Ability for drivers to use the mobile app
- Ability for customer support to troubleshoot problems
- Support for advanced features such as Power Management or Waitlist

A strong signal is also required for the ChargePoint Assure maintenance and management programs.

ChargePoint stations use cellular data connections to reach ChargePoint Cloud Services. This allows secure, PCI-compliant data connections without requiring any other form of internet connectivity at an install site or imposing additional network management responsibilities on a site host.

Each station has its own cellular connection.

Signal Strength and Quality

You must use a cellular signal detection device (such as a Siretta Snyder LTE or equivalent) to take signal strength readings at the exact proposed mounting location of the charging station. If the charging station does not have its own cellular connection, take the signal strength reading at the proposed mounting location of the gateway station.

In North America, ChargePoint products all support LTE bands 2, 4, and 5. The most commonly supported carriers to check during site evaluation are:

- US: AT&T, T-Mobile, and Verizon
- Canada: Rogers, Telus, and Bell

You must test the LTE signal strength at the proposed mounting location of every gateway station and ensure the location meets the minimum RSRQ at -12.5 dB or better, for RSRP measured at -90 dBm or better. Refer to the graph for acceptable combinations.

Note: These numbers are all negative, so -70 dBm is stronger than -85 dBm, and -90 dBm is weaker.

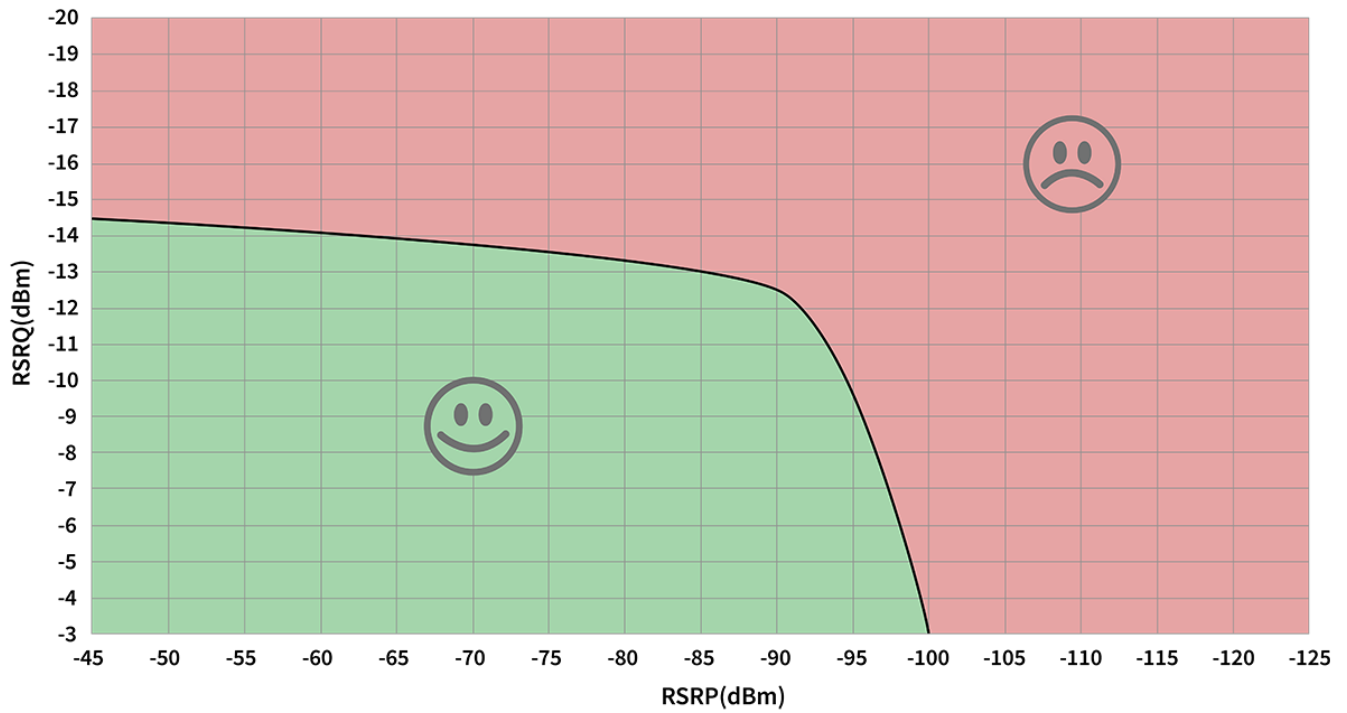

If the signal strength is weaker than this, take cellular readings at the location where any cellular signal booster antennas will be installed. Ensure enough signal exists for that repeater model. Install repeaters to boost the strength of the cellular signals. Repeaters are often required when installing charging stations in an underground garage or enclosed parking structure.

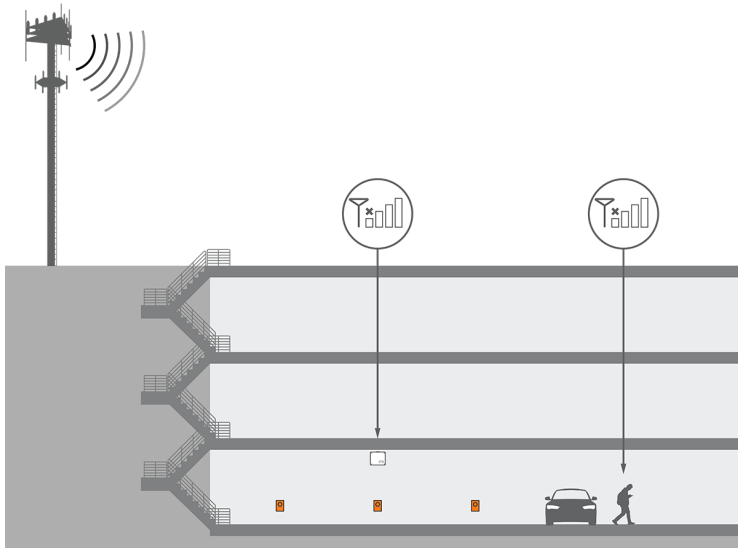

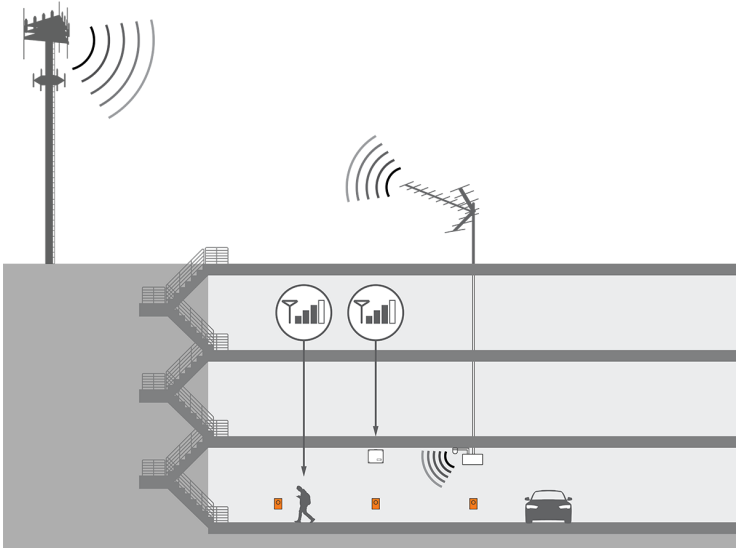

For other regions, or if the site does not have strong signal on these bands, contact your ChargePoint representative for additional solutions.

ChargePoint strongly recommends a consultation with a cellular connectivity specialist before all installations. A consultation can verify:

- Service with a supported carrier on a supported LTE band
- Available signal and local noise levels on applicable bands
- Site changes to correctly meet your needs, both for station bandwidth and other phone coverage for customer or tenant satisfaction

Repeaters

Some sites require repeaters to ensure strong signal to all stations. If a repeater is required, look for a model with these features:

- Specifically LTE compatible on the listed bands
- Multi-carrier
- Multi-band
- Not already dedicated to FirstNet or other first responder-specific networks
- Auto-gain recommended

Note: Do not rely on readings taken with a cell phone when conducting site surveys. Many signal boosters and network extenders may not be compatible with ChargePoint hardware, including certain types of Distributed Antenna Systems (DAS), micro/nano/pico/femto-cells, and carrier- or band-specific signal boosters.

Pedestal Mount Concrete Preparation 5

Concrete Mounting Template

You must use a ChargePoint Concrete Mounting Template (CMT) when installing a new pedestal mount charging station or replacing an existing non-ChargePoint pedestal mount station.

Use a CMT when installing charging stations on existing concrete (on an intermediate floor only).

You must order the CP6000 CMT separately, with sufficient lead time before site construction. This kit ships separately from the ChargePoint CP6000 charging station.

- a. Upper template
- b. Lower template
- c. Nuts (x 15)
- d. Washers (x 18)
- e. Anchor bolts (x 3)

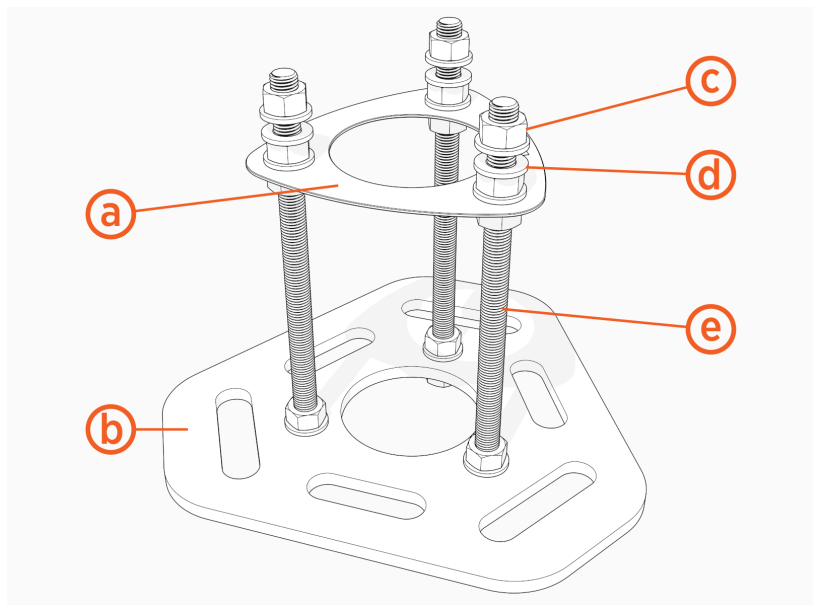

Note: You do not need a CMT if you are installing a wall mount charging station or replacing an existing ChargePoint station.

The Concrete Mounting Template kit components you need to use, the tools required, and the installation steps vary depending on the type of installation: new concrete or existing concrete.



WARNING: Do not use expanding anchor bolts. Do not install the CP6000 on an asphalt surface.

Tools and Materials

In addition to the CP6000 Concrete Mounting Template kit, the site construction team needs:

- Digging tools (shovel, spade, etc.)
- Materials to prepare the form for pouring concrete
- Concrete as specified by site drawings
- Rebar as specified by site drawings
- 24 mm (1 in) wrench
- Level
- Cut-resistant gloves
- Drill or hydraulic hole punch (if using armored cable)
- Conduit, ducting, or armored cable in the amounts and types specified by site drawings, that complies with local code (see the rest of this document for conduit sizes and routing)

Installation into New Concrete



WARNING: Failure to install the ChargePoint CP6000 in accordance with these instructions and all local building practices, climate conditions, safety standards, and all applicable codes and ordinances may lead to risk of death, injury, or property damage, and will void the Limited One-Year Parts Exchange Warranty.

1. Trench and excavate an opening to accommodate the wiring conduit and the concrete mounting pad that meets local codes and requirements, per site drawings.
2. Run conduit to each station as needed. If the station needs wired Ethernet access, run Ethernet conduit.
3. Build the form and lay rebar for the foundation.
 - The concrete block must measure at least 600 mm (24 in) on all sides.
 - The conduit stub-up needs to measure between 152 mm (6 in) and 590 mm (23.2 in) above the concrete surface



IMPORTANT: It is critical that the conduits are positioned properly and plumb. The tolerance where the conduits enter the station is 2 mm (1/16 in).

4. Align the CP6000 CMT over the conduit stub-ups with the two bolts facing forward and the third bolt to the rear.

- Slide the CP6000 CMT over the conduit stub-ups until the top surface of the template is level with the top surface of the concrete when poured.

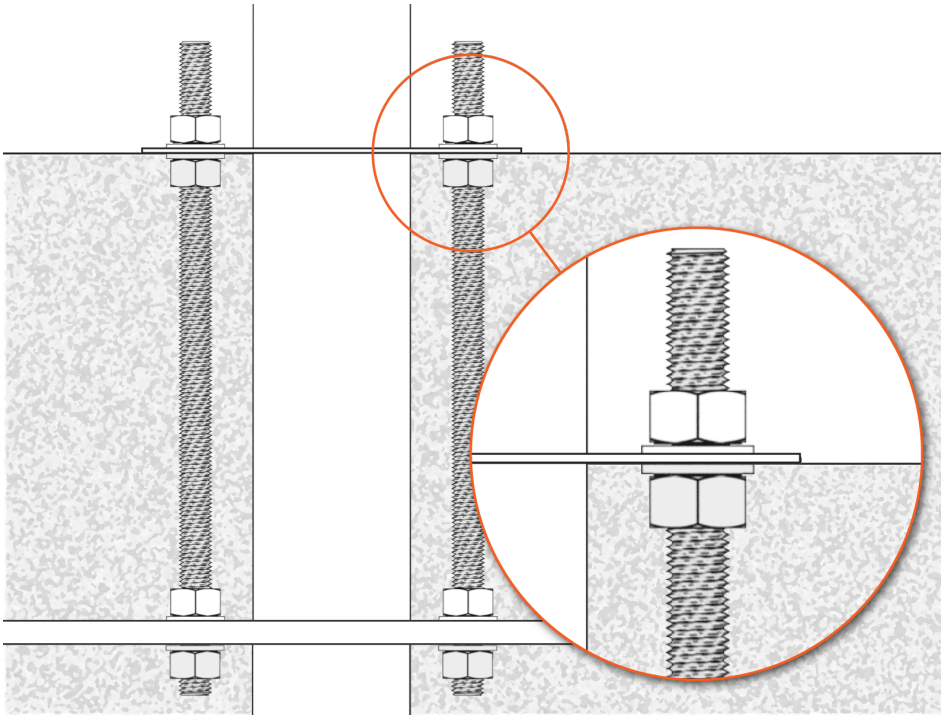

The bottom of the upper template **(a)** must align with the surface of the concrete **(b)**.

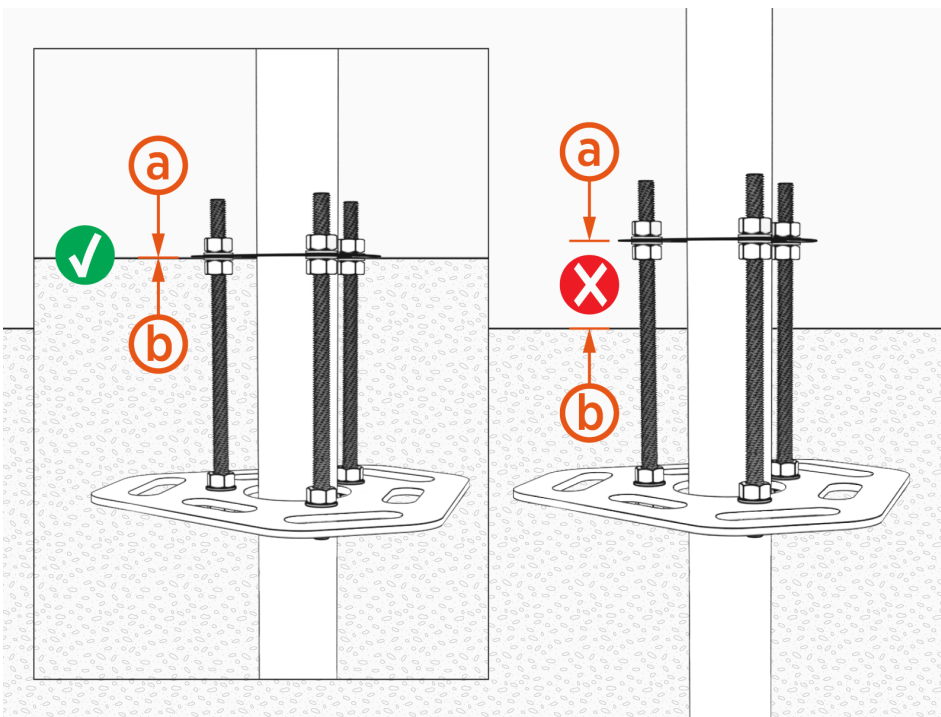

- Ensure the conduits are plumb.

7. Use a level to check that the CP6000 CMT is level from front to back and from side to side.
8. Conduit height (**c**) must be between 152 mm (6 in) and 590 (23-1/4 in). Each bolt (**d**) must extend between 60 mm (2-1/2 in) and 100 mm (4 in) above the concrete surface.

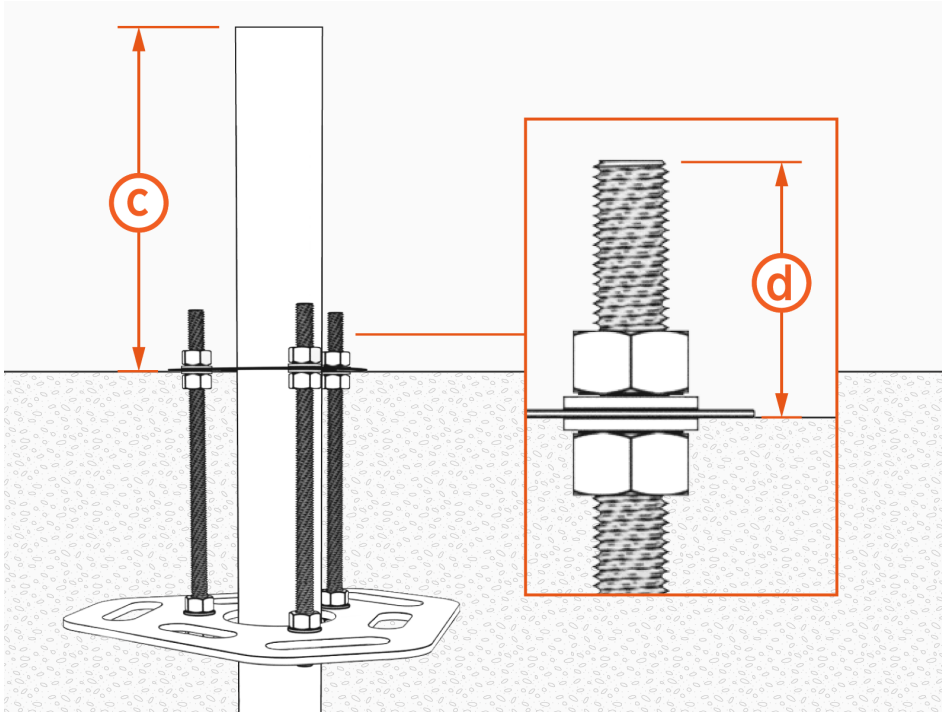

9. Before pouring concrete, tie the CP6000 CMT to rebar to help hold it in place.

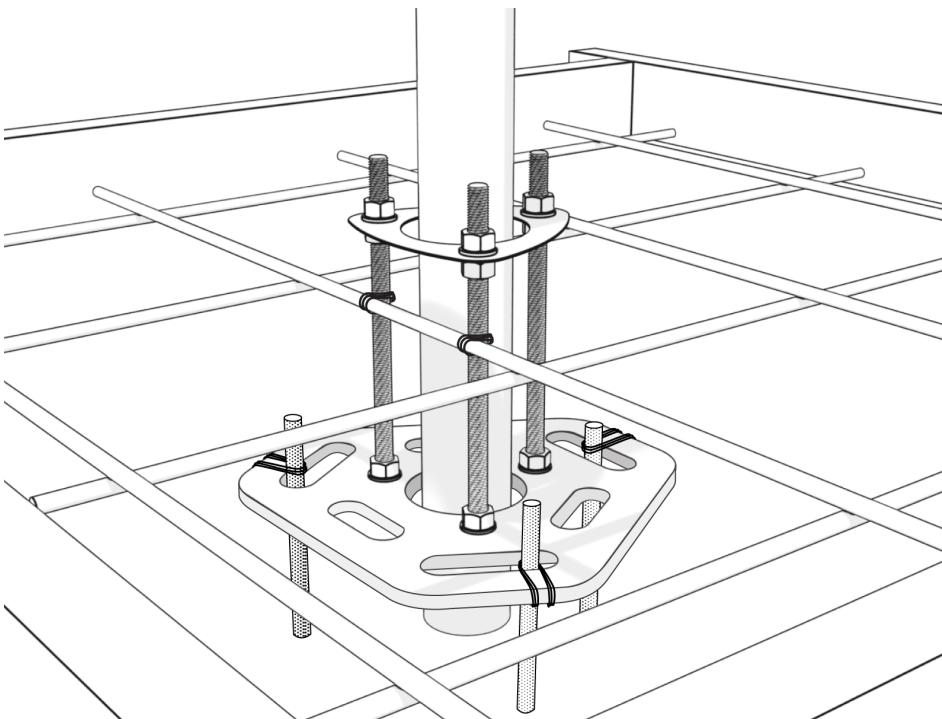



IMPORTANT: The CP6000 CMT and the conduit must be secured in place to prevent them from moving out of position while the concrete is poured and curing.

10. Pour the concrete.

Note: Make sure the concrete surface between the conduits is completely level and free of any irregularities.

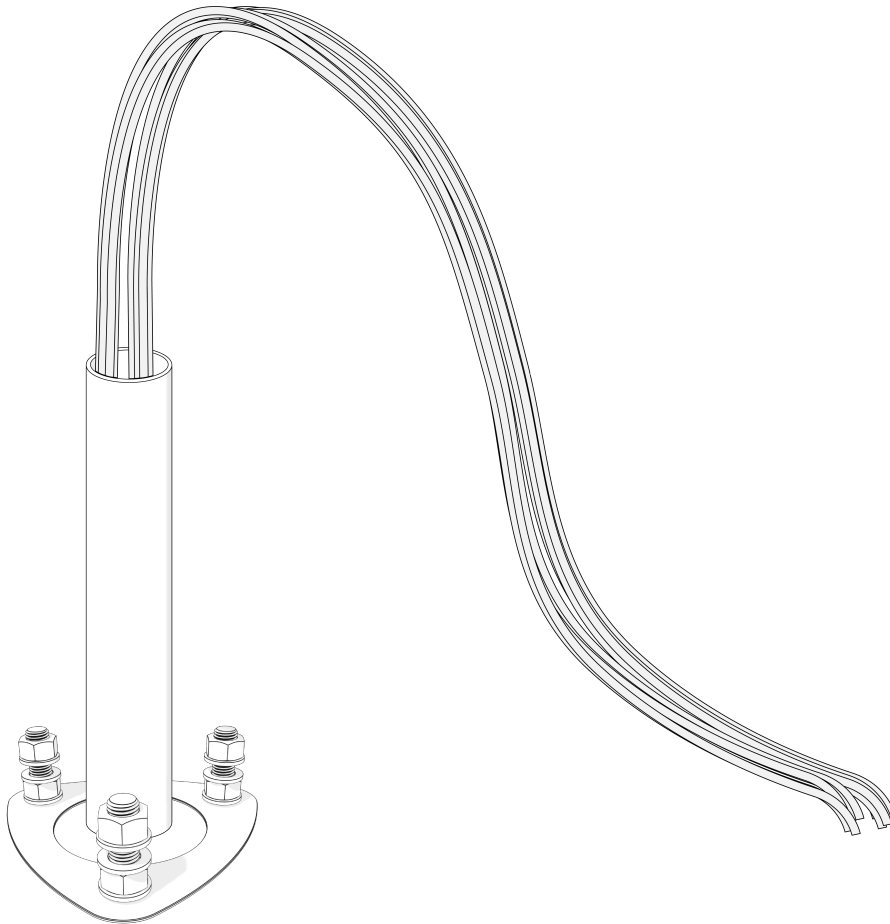

11. Refer to the measurements in this guide and ensure the anchor rod locations are correct before the concrete is dry.
12. Use a level to ensure the bolts are plumb.

You are now ready to install the CP6000 pedestal mount charging station.

Install on Existing Concrete



IMPORTANT: Always check local codes to ensure compliance. You may need to adjust these instructions to comply with codes that apply at your installation location.

Review the CP6000 Site Design Guide and ensure that the dimensions of the existing concrete slab meet the requirements.

If you are installing a Cable Management Kit (CMK), make sure there is adequate clearance behind the power stub-up for the CMK.

To safely mount a CP6000 charging station, the concrete must be at least 150 mm (6 in) thick. At this thickness, all of the CP6000 mounting bolts must be positioned as follows:

- At least 380 mm (15 in) from the front edge
- At least 300 mm (12 in) from the side edges
- At least 150 mm (6 in) from the rear edge of the concrete slab



IMPORTANT: If the existing pad does not meet the specifications above, a structural engineer must inspect and approve the pad for CP6000 charging station dimensions and weight.

Replace an Existing Charging Station

If you are replacing a CPF50 charging station, contact ChargePoint to order a CPF50 Adapter Kit.

If an existing charging station (from a manufacturer other than ChargePoint) is already in place at the installation site, complete these tasks:

- Turn off all power to the station and disassemble according to the original manufacturer's instructions.
- Cut away any existing bolts or non-power conduit stub-up to ground level.
- You may need to plug cut-away conduits at the slab end and disconnect wiring at the other end.



IMPORTANT: If existing conduit stub-up diameter is greater than 32 mm (1-1/4 in), you must remove the concrete and replace it.

Tools Required

Electric hammer drill with 12 mm (1/2 in) or larger chuck.

Consumables Required

The following table lists and describes consumable items that you will need. The quantity listed in the table is based on installation of one charging station.

Note: The consumption rate of these products varies depending on conditions at the installation site.

Quantity	Description	Purpose
1	Epoxy adhesive for concrete such as Hilti RE-500	Fill drilled holes.
1	Electrical cleaning and maintenance aerosol, any angle spray duster, 235 ml (8 oz)	Clean drilled holes. Note: Compressed air will work.
1	Slow spiral round-shank masonry drill bit <ul style="list-style-type: none"> • 19 mm (3/4 in) diameter • 12.5 mm (1/2 in) shank • 254 mm (10 in) drill depth • 305 mm (12 in) length overall 	Drill 19 mm (3/4 in) holes in concrete. Note: The holes must be at least 150 mm (6 in) deep.
1	Drill bit for concrete embedded rebar, round <ul style="list-style-type: none"> • 19 mm (3/4 in) bit size • 12.5 mm (1/2 in) shank diameter • 305 mm (12 in) length overall 	Drill 19 mm (3/4 in) hole through rebar.
1	Nylon loop handle brush <ul style="list-style-type: none"> • 19 mm (3/4 in) brush diameter • 75 mm (3 in) length brush • 216 mm (8 1/2 in) length overall 	Clean drilled holes.
1	Push-on round cap, fits 16 mm (5/8 in) - 17.5 mm (11/16 in) OD, 12.7 mm (1/2 in) inside height, pack of 100	Keeps the epoxy inside the drilled holes in situations where the slab is only 150 mm (6 in) deep.

Installation Instructions

- 1. Remove the lower template and all nuts and washers from below the upper template.

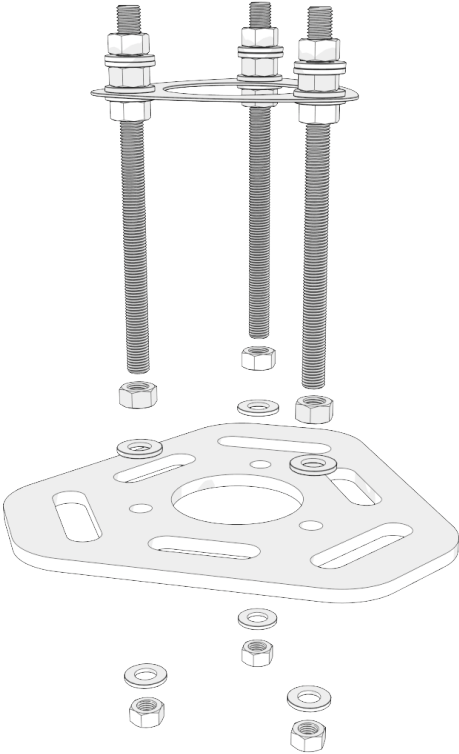

2. Place the lower template on the concrete and mark the hole locations.
 - When placing the template, consider the charging station's total footprint.
 - If installing over an existing conduit stub-up or armored cable, position the center of the template around that stub-up / cable.

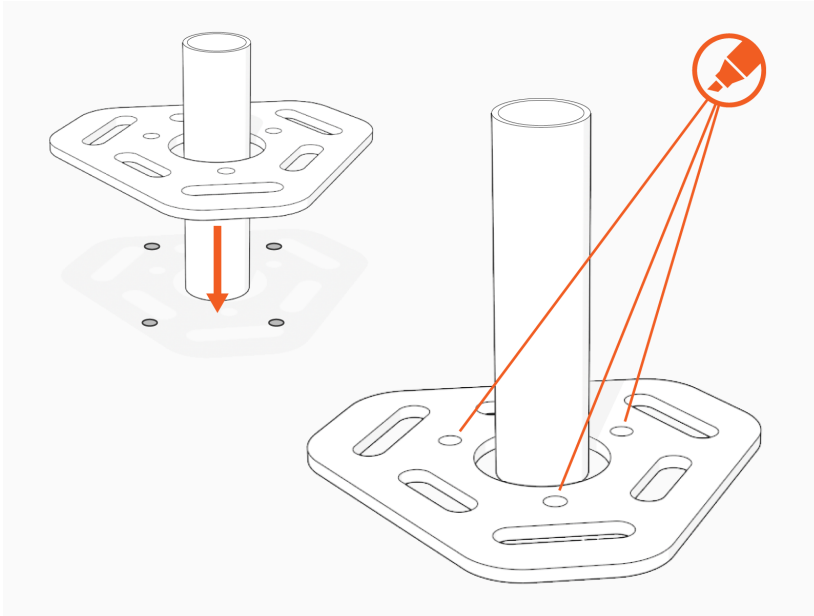

3. Remove the template and drill three 19 mm (0.75 in) diameter holes 250 mm (9.85 in) deep into the concrete.
 - You may need two drill bits: one for the concrete (with the pilot) and another for the rebar (without the pilot). Always start the hole using the standard drill bit, and then switch to the rebar drill bit only if drilling through rebar.

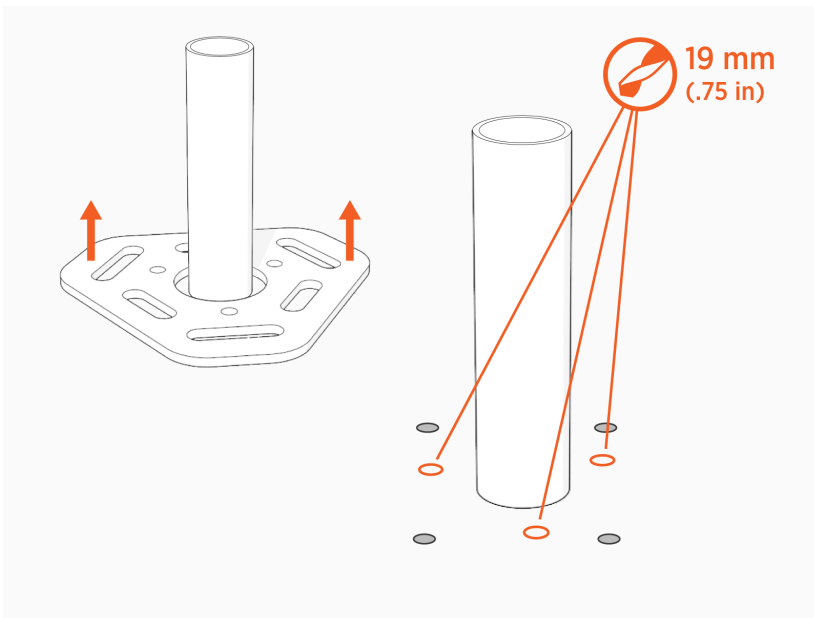

-
4. Remove all dust from inside the drilled holes using compressed air, a vacuum, or a brush.
 5. Remove the bolts from the upper template.
 6. Fill each hole with epoxy to about 65 to 75 mm (2.5 to 3 in) below the top of the hole. Continue immediately to the next step because the epoxy sets quickly.

Note: Inserting the threaded bolts displaces the epoxy, causing it to fill the holes to the grade level. If the epoxy is below grade level after the next step, add more epoxy.

7. Place the upper template over the holes.
8. Insert the bolts through the upper template into the holes.



IMPORTANT: Rotate the bolts as you insert them. This allows the epoxy to fully coat the threads of the bolts, reducing the amount of trapped air.

Note: Leave the upper template in place.

9. Use a bubble level to ensure the bolts are plumb.
10. Allow the epoxy to cure (depending on cure times recommended by the epoxy manufacturer).

You are now ready to install the CP6000 pedestal mount charging station.



chargepoint.com/support

75-001535-01 r2