

ChargePoint[®] Express 280



Express 280

Express 280 Specifications

Station Electrical Input	
Input Rating	North America: 3-phase, 480WYE VAC (91.5 kVA), 100 A, 60 Hz
Wiring	L1, L2, L3, Earth
Short Circuit Current Rating	65 kA

Station Electrical Output	
Max Output Power	80 kW
Output Voltage, Charging	100 to 1000 VDC
Max Output Current	CHAdeMO (North America): 140 A CCS1: 200 A North American Charging Standard (NACS): 200 A
Power Modules per Station	2

Paired Station Electrical Output	
Paired Max Output Power	160 kW
Output Voltage, Charging	100 to 1000 VDC
Paired Max Output Current	CHAdeMO (North America): 140 A CCS1: 250 A NACS: 250 A
Power Modules per Pair	4

Power Module Output	
Max Output Power	40 kW
Max Output Current	100 A
Power Conversion Efficiency	Up to 96%
Power Factor	0.99 at full load

Power Module Specifications	
Power Module Dimensions	760 mm H x 430 mm W x 130 mm D (2 ft 6 in x 1 ft 5 in x 5 ft)
Power Module Weight	45 kg (98.5 lb)
Power Module Cooling	Liquid Cooling Technology
Harmonics	iTHD < 5% (Complies with IEEE 519)

ChargePoint, Inc. reserves the right to alter product offerings and specifications at any time without notice and is not responsible for typographical or graphical errors that may appear in this document.

Functional Interfaces	
Number of Connectors	Up to two connectors per station
Supported Connector Types	CHAdEMO CCS1 (SAE J1772™ Combo) NACS
Cable Length	Standard 5.4 m (18 ft) with Cable Management Kit (CMK)* Medium 7.5 m (24 ft) with Tall Cable Management Kit (CMK)*
LCD Display	Full-color 254 mm (10 in) display for driver interaction
Authentication	RFID: ISO 15693, ISO 14443, NEMA EVSE 1.2-2015 (UR) Tap to Charge (NFC on Apple & Android, contactless credit card) ISO 15118-2, Plug&Charge Remote: Mobile and in vehicle (if supported by vehicle)

* Horizontal reach to typical vehicle charging port: 3.76 m (12 ft 4 in) with Standard cable.

Connectivity Features	
Vehicle Safety Communication	CHAdEMO: JEVs G104 over CAN CCS1 and NACS: SAE J1772 over PLC
Plug-Out Detection	Power terminated per JEVs G104 (CHAdEMO), and SAE J2931 (CCS1)
Local Area Network	2.4 GHz and 5 GHz WiFi (802.11 b/g/n)
Wide Area Network	4G LTE
Supported Communication Protocols	OCPP 1.6J
Service and Maintenance	Remote system monitoring, diagnostic, and proactive maintenance

Safety and Operational Ratings	
Station Enclosure Rating	Type 3R
Station Impact Rating	IK10
Safety and Compliance	UL and cUL listed: Complies with UL 2202, UL 2231-1, UL 2231-2 Energy Star, CTEP
Station Surge Protection	Tested to IEC 6100-4-5, Level 5 (6 kV @ 3,000 A)
EMC Compliance	North America: FCC part 15 Subpart B Class A
Storage Temperature	-40°C to 50°C (-40°F to 122°F)
Operating Temperature	-40°C to 50°C (-40°F to 122°F) with derating
Operational Altitude	< 3,000 m (9,800 ft)
Operating Humidity	Up to 95% at 50°C (122°F) non-condensing

ChargePoint, Inc. reserves the right to alter product offerings and specifications at any time without notice and is not responsible for typographical or graphical errors that may appear in this document.

Generic Specifications	
Station Enclosure Dimensions	Standard CMK: 2,413 mm H x 712 mm W x 438 mm D (7 ft 11 in x 2 ft 4 in x 1 ft 4 in) Tall CMK: 3,048 mm H x 712 mm W x 438 mm D (10 ft x 2 ft 4 in x 1 ft 4 in)
Station Weight (without Power Modules)	250 kg (551 lb)
Buy America	Buy America (FTA) options available upon request
Standard Warranty	Limited 2-Year Parts Warranty

Energy Management Features	
Dynamic Power Management	Allows a fixed maximum power output per station or lets the system dynamically manage the power distribution per station
Remote Energy Management	Manage output power via the ChargePoint Admin Portal, API, and Open ADR 2.0b VEN

ChargePoint, Inc. reserves the right to alter product offerings and specifications at any time without notice and is not responsible for typographical or graphical errors that may appear in this document.

Architectural Drawings

Note: Images are not to scale. Measurements appear in metric units (mm), followed by imperial equivalents (inches).

Express 280, with NACS and CCS1 connectors.

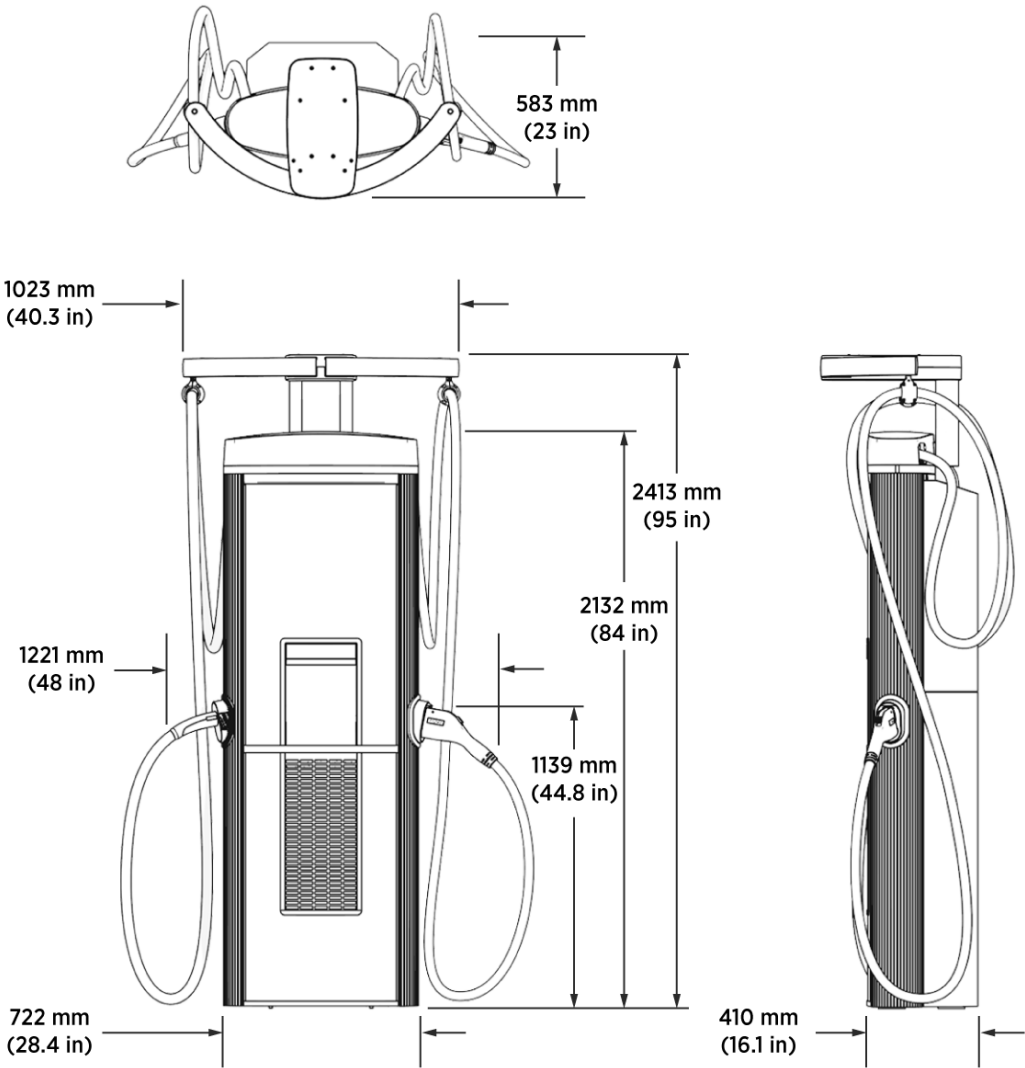

ChargePoint, Inc. reserves the right to alter product offerings and specifications at any time without notice and is not responsible for typographical or graphical errors that may appear in this document.

Note: Images are not to scale. Measurements appear in metric units (mm), followed by imperial equivalents (inches).

Express 280, with Tall CMK, and dual CCS1 connectors.

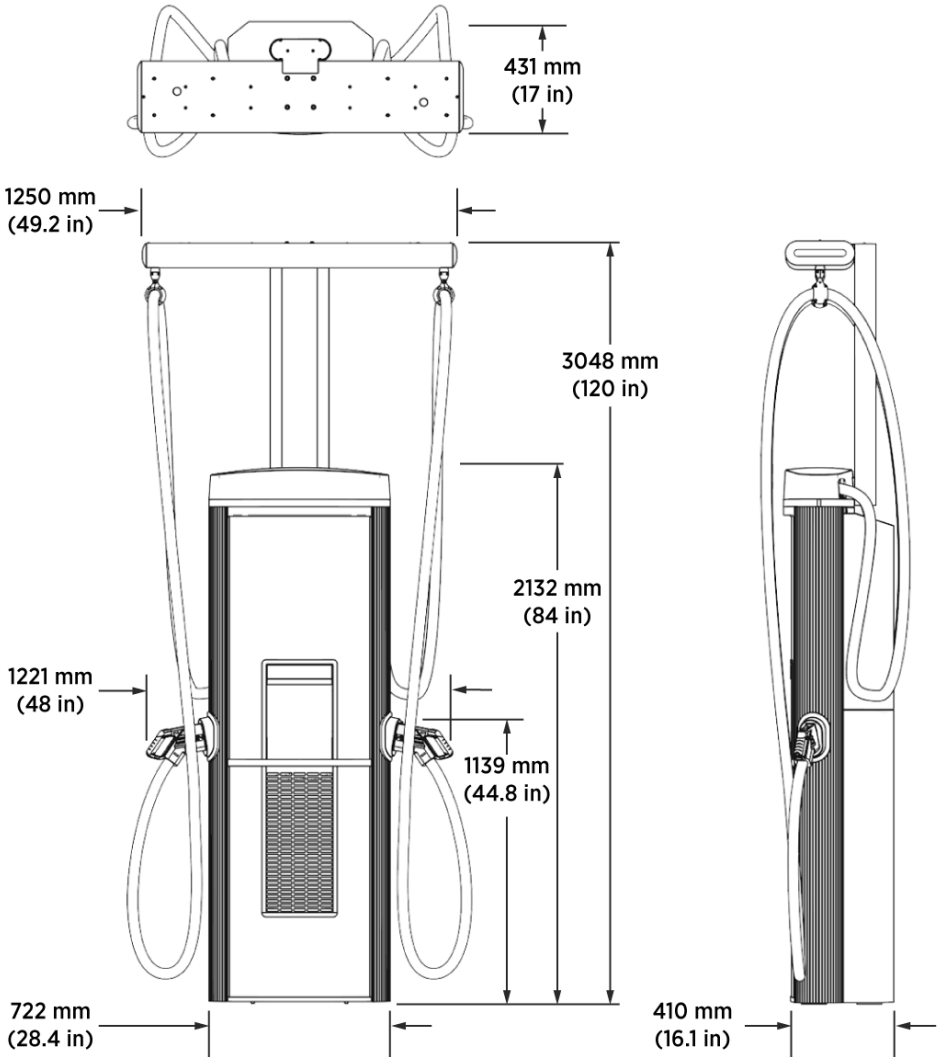

ChargePoint, Inc. reserves the right to alter product offerings and specifications at any time without notice and is not responsible for typographical or graphical errors that may appear in this document.

Note: Images are not to scale. Measurements appear in metric units (mm), followed by imperial equivalents (inches).

Express 280 Power Module

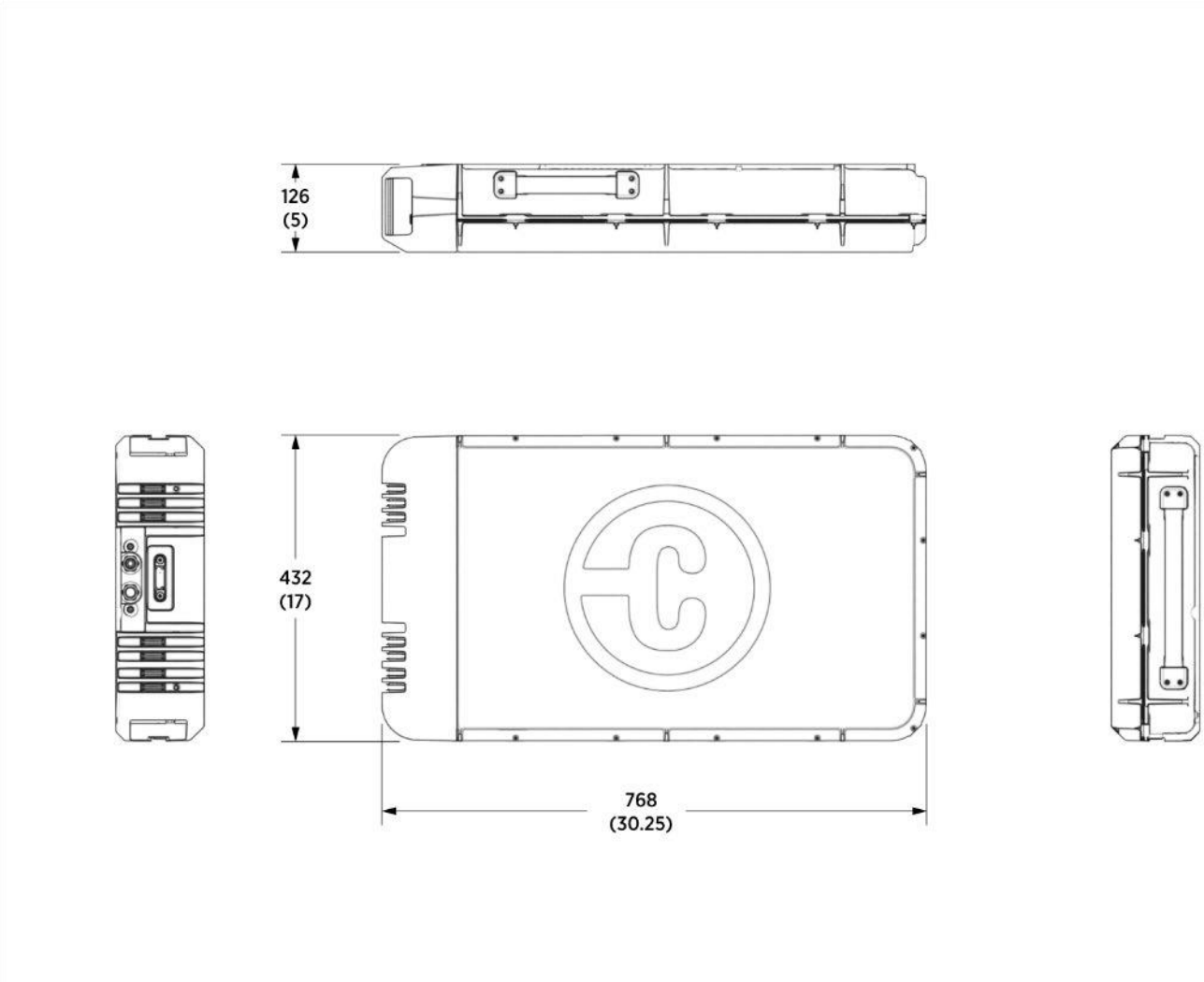



ChargePoint, Inc.
240 East Hacienda Avenue
Campbell, CA 95008-6617 USA
+1 408.841.4500 or +1
877.370.3802
US and Canada toll-free

Contact Us
Visit chargepoint.com
Email sales@chargepoint.com
Guillevin: jeff.hoogveld@guillevin.com

©2013-2024 ChargePoint, Inc. All rights reserved. This material is protected by the copyright laws of the United States and other countries. It may not be modified, reproduced, or distributed without the prior, express written consent of ChargePoint, Inc. CHARGEPOINT is a US, UK, and EU registered trademark and service mark of ChargePoint, Inc. and cannot be used without the prior written consent of ChargePoint. Feb 2024



ChargePoint, Inc. reserves the right to alter product offerings and specifications at any time without notice and is not responsible for typographical or graphical errors that may appear in this document.

Express 280

DC Fast Charging Station

Site Design Guide for Standalone and Paired Stations



IMPORTANT SAFETY INSTRUCTIONS

SAVE THESE INSTRUCTIONS

WARNING:



1. **Read and follow all warnings and instructions before servicing, installing, or operating the ChargePoint® charging station.** Install and operate only as instructed. Failure to do so may lead to death, injury, or property damage, and will void the Limited Warranty.
 2. **Only use licensed professionals to install your ChargePoint charging station and adhere to all national and local building codes and standards.** Before installing the ChargePoint charging station, consult with a licensed contractor, such as a licensed electrician, and use a trained installation expert to ensure compliance with local building and electrical codes and standards, climate conditions, safety standards, and all applicable codes and ordinances. **Only use licensed professionals certified by ChargePoint for installation and service, adhere to all national and local building codes and standards, and ensure compliance** with local building and electrical codes and standards, climate conditions, safety standards, and all applicable codes and ordinances. Inspect the charging station for proper installation before use.
 3. **Always ground the ChargePoint charging station.** Failure to ground the charging station can lead to risk of electrocution or fire. The charging station must be connected to a grounded, metal, permanent wiring system, or an equipment grounding conductor shall be run with circuit conductors and connected to the equipment grounding terminal or lead on the Electric Vehicle Supply Equipment (EVSE). Connections to the EVSE shall comply with all applicable codes and ordinances.
 4. **Install the ChargePoint charging station on a concrete pad using a ChargePoint-approved method.** Failure to install on a surface that can support the full weight of the charging station can result in death, personal injury, or property damage. Inspect the charging station for proper installation before use.
 5. **This charging station is not suitable for use in Class 1 hazardous locations, such as near flammable, explosive, or combustible vapors or gases.**
 6. **Supervise children near this device.**
 7. **Do not put fingers into the electric vehicle connector.**
 8. **Do not use this product if any cable is frayed, has broken insulation, or shows any other signs of damage.**
 9. **Do not use this product if the enclosure or the electric vehicle connector is broken, cracked, open, or shows any other signs of damage.**
 10. **Use only copper conductor wire rated for 90 °C (194 °F).**
-



IMPORTANT: Under no circumstances will compliance with the information in a ChargePoint guide such as this one relieve the user of the responsibility to comply with all applicable codes and safety standards. This document describes approved procedures. If it is not possible to perform the procedures as indicated, contact ChargePoint. **ChargePoint is not responsible for any damages that may result from custom installations or procedures not described in this document or that fail to adhere to ChargePoint recommendations.**

Product Disposal

Do not dispose of as part of unsorted domestic waste. Inquire with local authorities regarding proper disposal. Product materials are recyclable as marked.

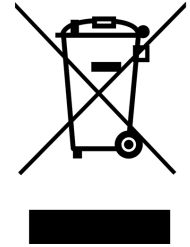

Document Accuracy

The specifications and other information in this document were verified to be accurate and complete at the time of its publication. However, due to ongoing product improvement, this information is subject to change at any time without prior notice. For the latest information, see our documentation online at chargepoint.com/guides.

Copyright and Trademarks

©2013-2023 ChargePoint, Inc. All rights reserved. This material is protected by the copyright laws of the United States and other countries. It may not be modified, reproduced, or distributed without the prior, express written consent of ChargePoint, Inc. CHARGEPOINT is a US, UK, and EU registered trademark and service mark of ChargePoint, Inc. and cannot be used without the prior written consent of ChargePoint.

Symbols

This guide and product use the following symbols:



DANGER: Risk of electric shock



WARNING: Risk of personal harm or death



CAUTION: Risk of equipment or property damage



IMPORTANT: Crucial step for installation success



Read the manual for instructions



Ground/protective earth

Illustrations Used in This Document

The illustrations used in this document are for demonstration purposes only and may not be an exact representation of the product. However, unless otherwise specified, the underlying instructions are accurate for the product.

Contents

Important Safety Instructions	ii
1 Site Design Guidelines	1
Accessing ChargePoint Documentation	1
Pairing Two Express 280s	2
Initial Site Guidelines	2
Plan for Future Charging Capacity	3
Charging Station Placement	3
2 Civil and Mechanical Design	8
Component Dimensions and Weight	8
Mounting Specifications for Pads	8
Drainage	10
Clearances	11
Wheel Stops and Bollards	13
Pairing Previously Installed Charging Stations	16
Ventilation	17
Accessibility	17
Signage	17
3 Electrical Design	18
Upstream Components	18
Grounding Requirements	20
Shunt Trip Wiring (Optional)	21
Conduit	22
Wiring Requirements for Standalone Stations	23
Additional Wiring Requirements for Paired Stations	23
Wiring Diagram	25
4 Connectivity	28

Site Design Guidelines 1

This document describes how to design an installation site for the ChargePoint® Express 280 DC fast charging station and install the Concrete Mounting Template, before station installation. An Express 280 station can be installed to operate by itself (called “Standalone”) or to share power with one other Express 280 station for higher throughput (called “Paired”).

IMPORTANT: You must be a licensed electrician and complete online training to become a ChargePoint certified installer. If you do not complete training, you cannot access the ChargePoint network to complete installation.



Find online training at: chargepoint.com/installers

If the charging station is not installed by a ChargePoint certified installer, using a ChargePoint approved method, it is not covered under warranty and ChargePoint is not responsible for any malfunctions.

Accessing ChargePoint Documentation

Access ChargePoint documents at chargepoint.com/guides.

Document	Content	Primary Audiences
Datasheet	Full station specifications	Site designer, installer, and station owner
Site Design Guide	Civil, mechanical, and electrical guidelines to scope and construct the site	Site designer or engineer of record
Concrete Mounting Template Guide	Instructions to embed the charging station template in a concrete pad with anchor bolts and conduit placement	Site construction contractor
Surface Conduit Entry Kit Guide	Instructions for sites where conduit cannot be run underground	Installer
Construction Signoff Form	Checklists used by contractors to ensure the site is correctly completed and ready for product installation	Site construction contractor
Installation Guide	Anchoring, wiring, and powering on	Installer

Document	Content	Primary Audiences
Operation and Maintenance Guide	Operation and preventive maintenance information	Station owner, facility manager, and technician
Service Guide	Component replacement procedures, including optional components	Service technician
Declaration of Conformity	Statement of conformity with directives	Purchasers and public



CAUTION: Use low torque settings when working with power tools during installation or servicing. Over-torquing can damage the equipment.



WARNING: Do not install or service the charging station in inclement weather. If you work in rain or wind, you must use a weather-proof shelter that covers all boxes and components.

Note: For all charging station specifications other than dimensions and weights, refer to the product's Datasheet found online at chargepoint.com/guides.

For assistance, go to chargepoint.com/support and find your region's technical support number.

Installing an Express 280 requires two people and takes approximately 3-4 hours. This time estimate does not include the time needed to pull DC and Ethernet cable for a Paired installation if it is not already done. Paired installation also requires contacting a ChargePoint support technician to perform any required software updates and configuration.



IMPORTANT: Ensure the installation complies with all applicable codes and ordinances.

Pairing Two Express 280s

The Express 280 can be installed either as a standalone system, or paired with another Express 280 using a DC connection to more flexibly share load. The two Power Modules in the base of each charging station can be shared in any combination according to charging need. This allows high power output in sites with space constraints.

To pair two charging stations, all of the following are required:

- Additional conduit or ducting correctly installed between the two charging stations for DC conductors and Ethernet wiring
- Both stations must be provisioned for full power back to the panel (not allowed on “power select” stations)

Initial Site Guidelines

An onsite evaluation is needed to determine conduit and wiring requirements from the panel to the proposed parking spaces, as well as to measure cellular signal levels and identify suitable locations for any necessary cellular signal booster equipment.

If you have pre-existing infrastructure or are using your own preferred electrical contractor to prepare your site, you must complete a Construction Signoff Form to certify compliance with electrical specification requirements and to ensure everything was prepared to ChargePoint specifications.



IMPORTANT: Always check local codes or consult an engineer to ensure the site is prepared in compliance with all applicable regulations. Local authorities might not allow a unit to operate if it is not installed to code.

Plan for Future Charging Capacity

ChargePoint recommends planning to install charging stations for 5-10% of parking spaces, or 10-15% for high electric vehicle (EV) adoption areas like California. Designing electrical infrastructure to support current and future needs for EV charging helps avoid costly modifications later as demand for EV charging grows.

Consider these methods to prepare a site for future charging stations in a later phase of work:

- Add extra capacity if electrical panels are being upgraded now
- Use sub-panels as a way to shorten electrical paths
- Oversize the conduit between the main electrical panel and future stations
- Install pull or junction boxes at the end of an existing row of charging stations, to ease cable pulls for future stations
- If a junction box or disconnect will be installed between rows of stations, oversize the wiring between the main panel and the junction box to prevent needing to re-pull wire later

Charging Station Placement

To help minimize costs, choose station locations that are as close as possible to the available electrical infrastructure. Selecting these types of locations helps minimize long conduit and wire runs, as well as any trenching work.



WARNING: The charging station must be installed on a level concrete base. Asphalt cannot support the full weight of the charging station. Failure to install on a level concrete base may cause the station to tip over, resulting in death, personal injury, or property damage.

Layout considerations:

- Determine appropriate ground anchoring locations where concrete exists or can be installed (no asphalt surfaces).
- Consider locations where it will be easy to add future stations.
- Determine the best conduit layout to minimize linear conduit costs to multiple parking spaces. If possible, avoid or minimize trenching requirements, especially more costly trenching to run conduit under asphalt surfaces.

- Determine if the existing utility service and electrical panel capacity is sufficient. Identify costs for any necessary upgrades and/or a new dedicated electrical panel. ChargePoint recommends using a certified electrician to evaluate available capacity and identify any upgrades that may be required.
- If a dedicated EV electrical panel is required, choose a panel located close to the existing electrical supply.
- Measure cellular signal levels to ensure adequate cellular coverage at the station locations. To ensure adequate signal strength in underground or enclosed parking structures, cellular repeaters may be required.
- ChargePoint recommends avoiding locations under trees where sap, pollen, or leaves would fall on the charging station and increase the station owner's site maintenance workload.

Guidelines for Different Parking Arrangements

- Choose adjacent parking spaces in an area with adequate lighting.
- Consider how easily drivers can find the stations they need to access.
- Check local requirements for accessibility and pathway width, sometimes called “path of travel”, to ensure that station placement does not restrict sidewalk use.
- The maximum reach from the station to charge port on a typical vehicle is approximately 3.76 m (12 ft 4 in) (a) at a height of 0.6 m (2 ft) (b) above the ground.
- Building a pad into the head of a parking space (instead of on the sidewalk) is permitted if local code allows it compared to the minimum parking space length and the pad meets all pad requirements listed in this document.

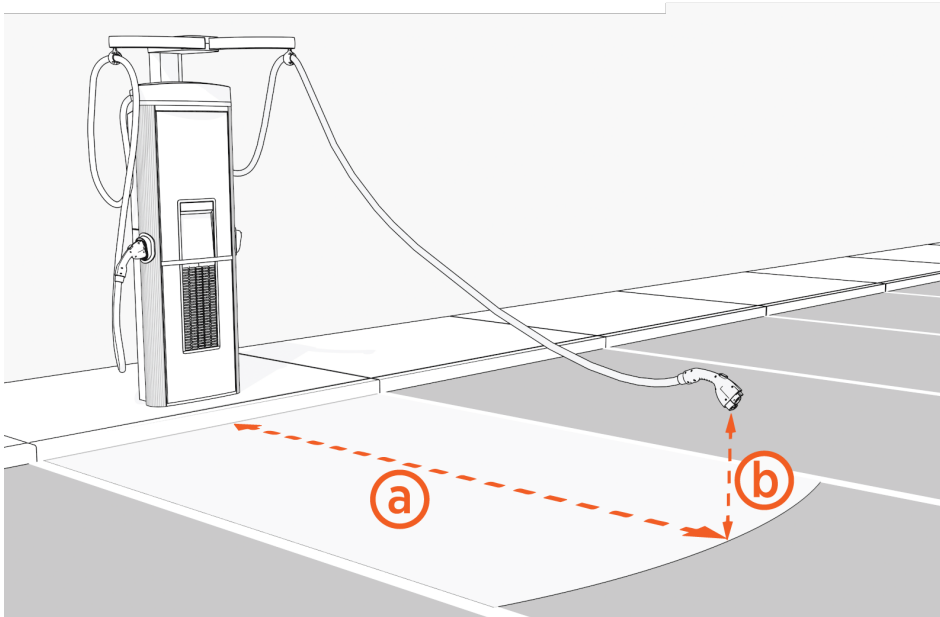

- The Express 280 can have different charging cable types (CCS1 and CHAdeMO) to offer flexibility, or it can have two of the same cable type. The cables cannot both charge at the same time.

-
- Two cable lengths are available:
 - Standard length cables are 5.4 m (17 ft 8 1/2 in) long and are used with standard Cable Management Kits (CMK)
 - Medium length cables are 7.6 m (24 ft 11 1/4 in) long and are used with longer cable management systems



IMPORTANT: Place each charging station to maximize cable reach for the varied charge port locations on different EVs.

Commercial or Public Station Placement, Single or Dual Cable

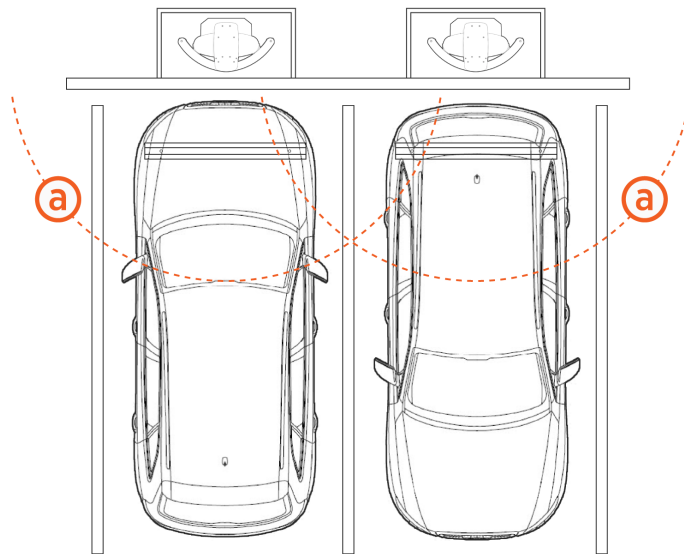

- a. Cable reach radius: 3.76 m (12 ft 4 in)

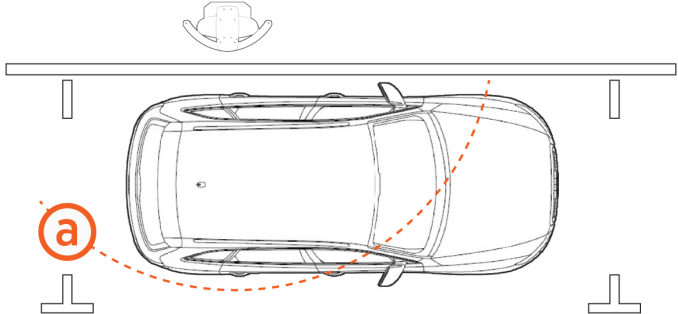
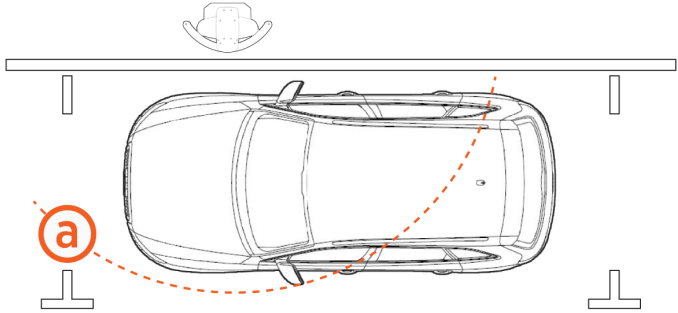

a. Cable reach radius: 3.76 m (12 ft 4 in)

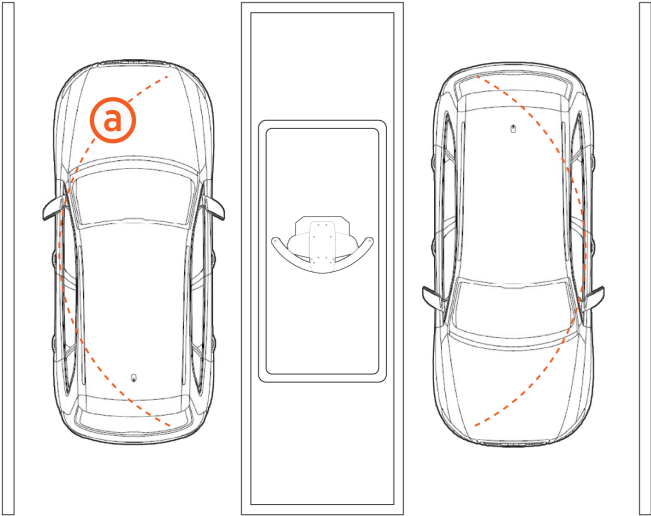

a. Cable reach radius: 3.76 m (12 ft 4 in)

Fleet Station Placement, Dual Cable

Center single stations with dual CCS1 cables between two parking spaces so that the cable runs down either side of the parking space.

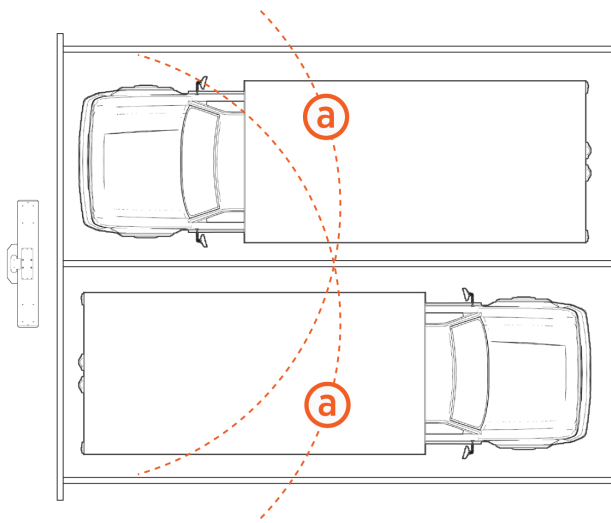

- a. Cable reach radius: Approximately 5.49 m (18 ft), depending on longer cable management system location

Note: Position single CCS1 cable stations at the top of parking spaces, as shown in the first commercial use case above.

Island Station Placement With Longer Cable Management System

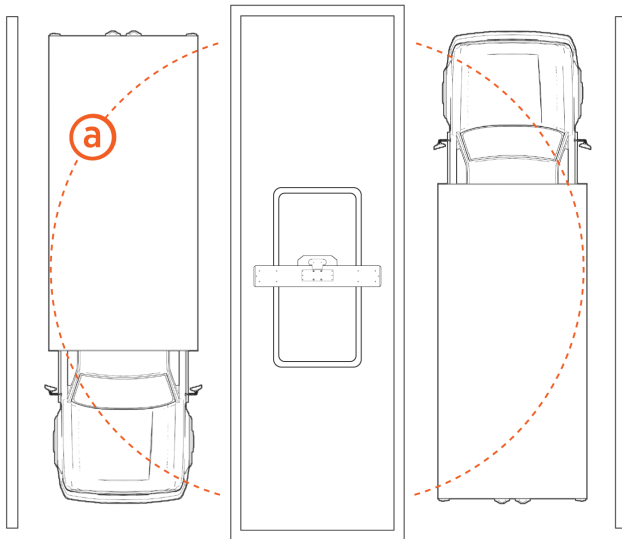

- a. Cable reach radius: Approximately 5.49 m (18 ft), depending on longer cable management system location

Civil and Mechanical Design 2

Use the guidance below to design the civil and mechanical aspects of the site.

Component Dimensions and Weight

The Express 280 is a vertical enclosure with the dimensions shown here.

Generic Specifications	
Station Enclosure Dimensions	2413 mm H x 712 mm W x 420 mm D (95 in x 28 in x 16.5 in)*
Power Module Dimensions	760 mm H x 430 mm W x 130 mm D (30 in x 16.9 in x 5.1 in)
Station Weight (without Power Modules)	250 kg (551 lb)
Power Module Weight	45 kg (98.5 lb)

* Includes Cable Management Kit (CMK)

Mounting Specifications for Pads

The station can be installed on either a newly poured pad or an existing concrete surface. The mounting surface must be smooth and cannot exceed a slope of 6.35 mm per 304.8 mm (0.25 inches per foot).



WARNING: If not installed correctly, the station may pose a fall hazard, leading to death, personal injury, or property damage. Always use the provided Concrete Mounting Template shown pre-installed in the Introduction, or a ChargePoint-approved surface mounting solution, to install the charging station. Always install in accordance with applicable codes and standards using licensed professionals. Non-approved installation methods are performed at the risk of the contractor and void the Limited One-Year Parts Exchange Warranty.

Note: Although new pad installation is the most common mounting method, Surface Conduit Entry (SCE) is also allowed. Contact ChargePoint for the approved mounting hardware if a site requires an SCE installation, a surface mount template for drilled and epoxied anchor bolts, or low clearance accommodation (such as a low ceiling parking garage).

- At least 305 mm (12 in) deep (or deep enough to be 305 mm (12 in) below the frost line)
- At least 1296 mm (51 in) on each side

- Contains #4 rebar or larger, top and bottom, 305 mm (12 in) on center
- Concrete 2500 PSI minimum

The above pad specifications are designed to meet these conditions:

- 170 mph wind speed
- Wind Risk Category I
- Wind Exposure D
- Seismic Importance Factor 1.0
- Hayward Fault with mapped spectral response accelerations $S_s=2.45$ $S_1=1.019$
- Seismic Design Category E
- Foundation of Sandy Soil with allowable stress = 1500 psf, $C_d = 1.33$

In some extreme conditions, a larger pad would be required. For sites with less stringent seismic, soil, or wind conditions, a smaller pad might be possible.

If the existing pad does not meet the specifications above, it must be inspected and approved by a structural engineer for the station’s dimensions and weight. If needed, give these structural design specifications to the structural engineer for verification:

Product Weight	340 kg (750 lbs)
Product Height from Ground	2.413 m (7.917 ft)
Product Width	0.42 m (1.378 ft)
Product Frontal Area	Height * Width
CG Height	1.12 m (3.66 ft)
Number of Anchor Bolts	4
Bolt Pattern	See dimensions below.
Anchor Bolt Size	M16 (5/8 in)
Anchor Bolt Embedment	229 mm (9 in)

Express 280 stations use the DC Universal Concrete Mounting Template (CMT), which also fits other DC fast charging stations such as the Express 250. This CMT is embedded in a newly poured concrete pad to position both the anchor bolts and the conduit stub-ups detailed above. For conduit and anchor bolt configurations and assembly instructions, see [DC Universal Concrete Mounting Template Guide](#).

The Express 280 anchor bolt pattern appears below.

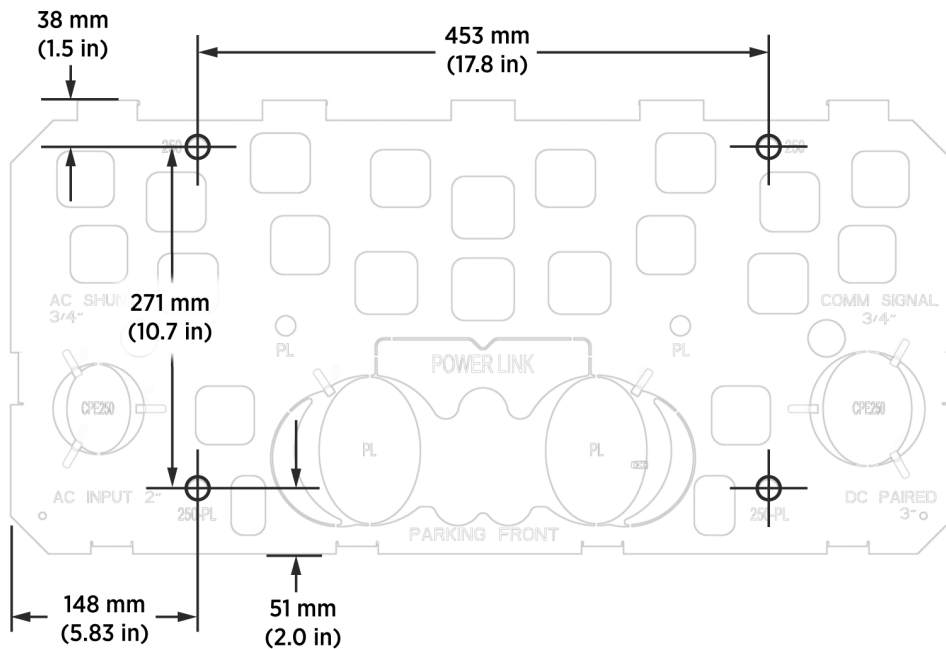

Drainage

Ensure any site slopes, walls, or fencing do not trap water around the installation site.



WARNING: Exposing the ChargePoint charging components to over 406 mm (16 in) of standing water could create an electrocution, shock, or fire hazard. Cut power to the charging station if it has been exposed to standing water and contact ChargePoint before the charging station is powered on.

Clearances

The Express 280 requires minimum functional and service clearances as shown below.

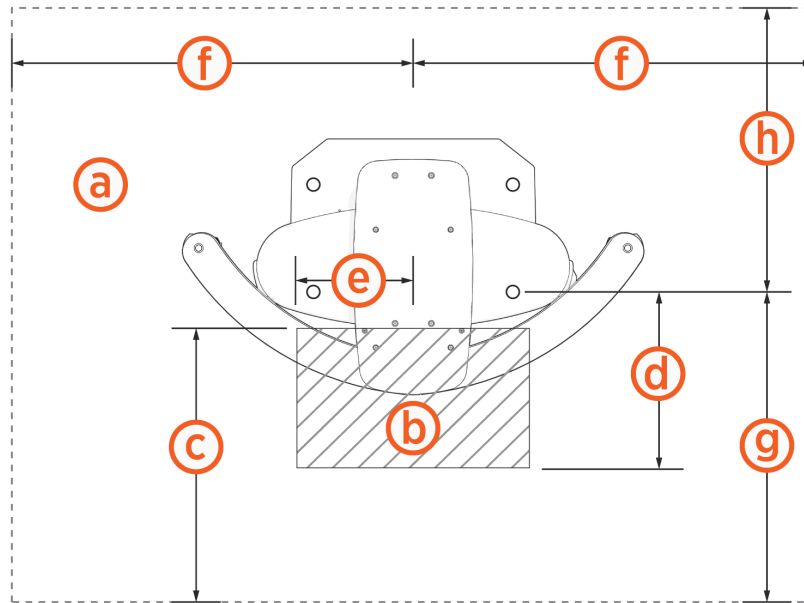

- a. Service clearance of open space (not necessarily at system grade)
- b. Power Module service clearance (at grade, measured from station front): 330.2 mm (1 ft 1 in)
- c. Front service clearance (measured from station front): 609.6 mm (2 ft)
- d. Power Module service clearance (measured from front anchor bolt): 383 mm (1 ft 3.1 in)
- e. Power Module service clearance (measured from station center): 290 mm (11.4 in)
- f. Side service clearance (measured from station center): 1072 mm (3 ft 6 in)
- g. Front service clearance (measured from front anchor bolt): 510 mm (1 ft 8.1 in)
- h. Rear service clearance (measured from front anchor bolt): 663 mm (2 ft 2.1 in)

Allow 26 mm (1 in) clearance above the station if installing a Cable Management Kit (CMK).

Note: Listed side clearances are the minimum required for operation and service. For paired charging stations, the bend radius of the DC cable and conduit might require spacing them further apart.

Note: Rear clearance must be at grade level +/- 25 mm (1 in).

Refer to [Ventilation](#) and check local and regional code for any additional clearance requirements.

Surface Conduit Entry

You can install Express 280 DC fast charging stations at sites where you cannot pour a new concrete pad or run conductors underground. The Surface Conduit Entry (SCE) kit allows surface drilling and epoxy installation of anchor bolts, as well as a rear conduit entry box for conductors to enter the station through surface wireways. The SCE kit supports both Standalone and Paired installations. The SCE kit also supports adding above-ground conduit to pair an already-installed Standalone station with another Express 280 for shared DC output.

Before beginning work, check that the site meets the basic requirements outlined below, as illustrated in the following image. Measurements are listed in mm (in).

- The panel breaker serving the charging station matches the site drawing requirements depending on local code and the type of installation: 80 kW Standalone, 160 kW Paired, 62.5 kW or 50 kW de-rated (when replacing a previous, lower-amperage system).
- The smooth, level concrete has been approved by a structural engineer for the Express 280 dimensions and weight, OR conforms to these general specifications*:
 - At least 305 mm (1 ft) deep (or deep enough to be 305 mm (1 ft) below the frost line)
 - At least 1296 mm (4 ft 3 in) on each side
 - Contains #4 rebar top and bottom 305 mm (1 ft) on center
 - Concrete 2500 PSI minimum

** These pad specifications are applicable in most conditions. In some extreme conditions, a larger pad would be required.*

- The cellular signal strength at the station location has been tested and is consistently strong. If RSRQ is measured at -10 dB or better, then RSRP can be -90 dBm or better. If RSRQ cannot be measured or is not adequate, RSRP must be -85 dBm or better. Visit [Connectivity](#) for more information.
- The service clearance of open space (not necessarily at system grade) extends a minimum of 610 mm (2 ft) beyond the station in front, and 1072 mm (3 ft 6 in) side to side centered on the station. See the images below for rear clearance depending on configuration.

If the conduit runs from the back of the SCE to the side(s), with rigid wireway elbows:

- The rear conduit clearance from the front anchor bolt at grade is 620 mm (24.4 in) (a)
- The recommended extra rear service clearance of open space (not necessarily at grade) is 925 mm (36.4 in) (b)

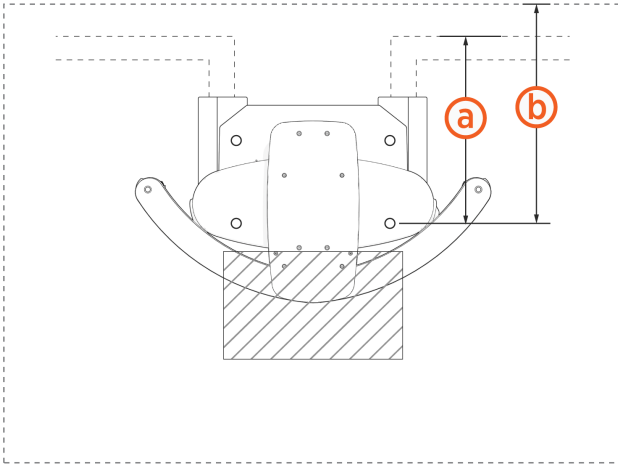

If the conduit runs from the back of the SCE straight back:

- The rear conduit clearance at grade is 470 mm (18.5 in) (a)
- The recommended extra rear service clearance of open space (not necessarily at grade) is 775 mm (30.5 in) (b) from the front anchor

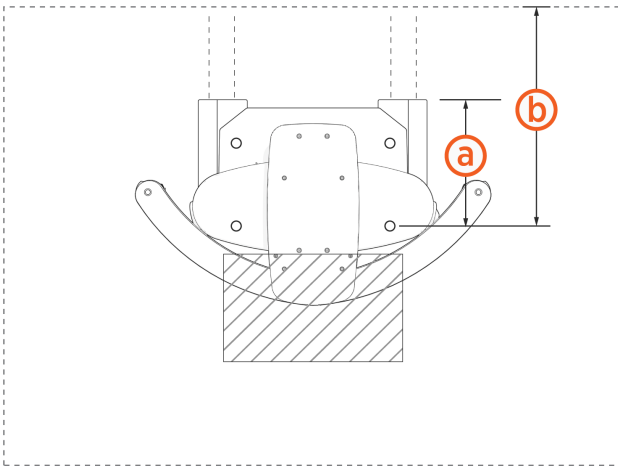

If the site does not meet these basic requirements, contact ChargePoint before continuing.

For more information, access ChargePoint documents at chargepoint.com/guides.

Wheel Stops and Bollards

Bollards and wheel stops are not explicitly required by ChargePoint. However, ChargePoint recommends these best practices and considerations when designing the site:

- Permanent bollards or wheel stops must not encroach upon the clearances listed in the clearance diagrams in this section. Removable bollards are allowed if service personnel have the ability to move them as needed.
- Where permitted by code, wheel stops are preferred over bollards for head-in or back-in spaces.

Wheel Stops

- When using wheel stops, consider the average vehicle overhang distance for the largest type of vehicle (passenger, bus, etc.), as well as leaving space for the driver to walk up and access the station.
- Position wheel stops to actively block at least one wheel, without presenting a trip hazard to pedestrians walking between vehicles.

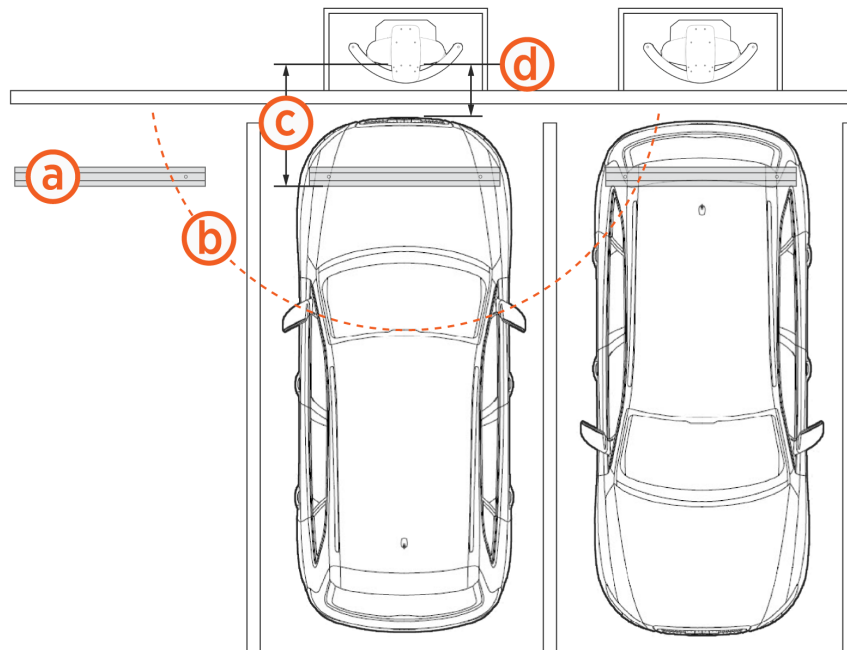

- a. Wheel stop, positioned to actively block at least one wheel
- b. Cable reach radius: 3.76 m (12 ft 4 in)
- c. Recommended distance between wheel stop and station: 1371 mm (4 ft 6 in) for passenger vehicles
- d. Recommended distance for walk-up access: 609 mm (2 ft)

Bollards

- When bollards are required by code, needed for snowy areas, or needed for curbside spaces, ensure bollard placement does not interfere with removing and replacing charge cables in the station's holsters.
- Try to minimize bollard interference with the movement of charge cables between the station and the vehicle. Bollard height is recommended to be no higher than 914 mm (36 in) where needed.
- Follow the measurements listed for bollards placement Express 280 standard (2.4 m) CMK:

- a. Anchor bolt to bollard inside edge: 391.95 mm (15.4 in)
- b. Anchor bolt to bollard front edge: 104 mm (4.1 in)
- c. Express 280 side to bollard inside edge: 257.00 mm (10.1 in)
- d. Express 280 front to bollard front edge: 55.54 mm (2.2 in)

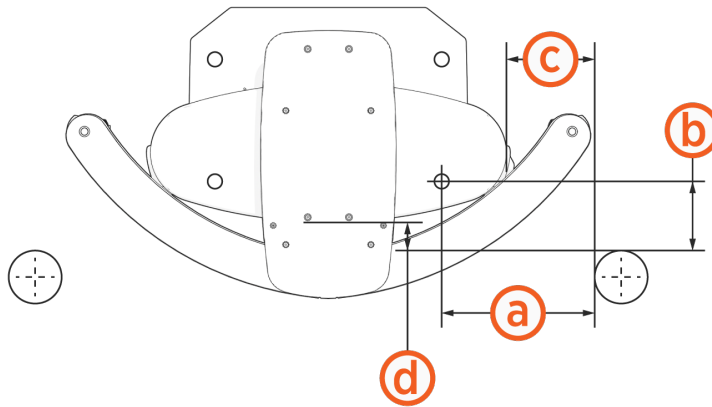

- Follow the measurements listed for bollards placement Express 280 tall (3.1 m) CMK:

- a. Anchor bolt to bollard inside edge: 590.50 mm (23.25 in)
- b. Anchor bolt to bollard front edge: 104.00 mm (4.1 in)
- c. Express 280 side to bollard inside edge: 457.00 mm (18.0 in)
- d. Express 280 front to bollard front edge: 55.54 mm (2.2 in)

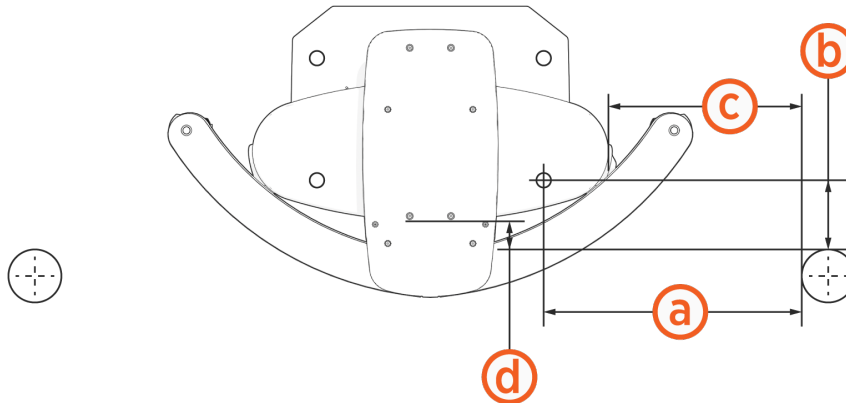

Pairing Previously Installed Charging Stations

If all site construction for paired charging is completed in advance, Express 280 stations can be initially installed as Standalone and paired at a later date. In that case, follow these additional steps:

- During initial site construction, install DC and communication conduit or ducting (as applicable by region) in advance.
- Extend side clearance at both DC conduit stub-up locations to 1.2 m (4 ft) to allow space for cable pulling equipment.
- Run a pull rope through the larger DC conduit before landing the charging stations. Do not pull DC cable in advance, as it is too thick to hide inside the cover panels without risking damage or unwanted electrical contact.
- Install a fishing tape in the smaller communication conduit to assist with routing the Ethernet cable later. If Ethernet is pulled in advance, leave 3.175 m (125 in) of wire above grade at each end.
- Use duct seal compound to seal the ends of the DC and communications conduit stub-ups. Seal the ends of the fishing tape to hang outside the conduit.
- Install the cover panels and extrusions on the Express 280 stations over the stub-ups as normal.

By only connecting AC wiring (and shunt trip if applicable), each station can perform as a Standalone station until the station owner is ready to pair them. At a later time, the stations can be paired by installing DC conductors, connecting Ethernet communication, and performing a firmware update if required. Refer to the *Express 280 Installation Guide* for further details.

Once two Express 280 are correctly paired, operation of both stations is inhibited if Ethernet connectivity is lost or one station loses power. This is a safety feature to prevent one Paired station from accidentally powering the other during maintenance.



WARNING: Do not connect DC power between the charging stations until both stations are ready to complete the full pairing configuration. Station firmware updates are required to enable full Paired behavior. Connecting power before the charging station is properly configured can create a safety risk or can damage equipment.



WARNING: If service is performed on either Paired charging station, both stations must be powered off at their AC disconnect switches and locked out/tagged out for safety.

Ventilation

Ensure that any installation, especially an indoor installation, has adequate airflow to dissipate the station's heat at maximum operation. Each charging station emits approximately 3.3 kW of waste heat at maximum operation.

The station location must allow fresh ambient airflow. Restriction of airflow might result in reduced maximum performance. Do not install a station where it is exposed to air that is heated above ambient temperatures.

In addition to the service clearances listed in [Clearances](#), consider these figures for site layout:

- If a charging station will have a wall directly behind it, minimum rear clearance is 305 mm (12 in).
- If two Express 280 stations will be positioned back to back, increase the rear clearance to a shared 610 mm (24 in) for both stations to reduce exhaust recirculation.

Accessibility

To meet the accessibility requirements, the Express 280 charging cables are no more than 1220 mm (48 in) above ground and no more than 254 mm (10 in) away.

This complies with American Disability Act (ADA) requirements, if the station is installed at grade. If your installation must comply with ADA standards, or the disability access regulations for other regions, consider this when designing the height of the pad or when planning a wall-mounted installation.

Also consider site design factors such as placement of bollards, wheel stops, or other vehicle obstacles when planning charging station access for disabled parking stalls. Check disability access regulations for guidance on the clearances needed for wheelchair access to charging cables and user interfaces.

Signage

Refer to local and regional code to design the following elements for the site:

- Any required re-striping of parking spaces
- EV or Accessible EV signs
- EV or Accessible EV paint markings on and around the parking spaces

Electrical Design 3

The default Express 280 installation requires service wiring to be installed underground. If a site requires surface mounting, contact ChargePoint before beginning work, to obtain an approved surface installation method. Conduit and wire size are determined based on the length of runs from the electrical panel to the station location. Service wiring must be run through conduit or ducting to comply with local electrical codes. Consult national and local codes or a project engineer to determine the grade, quality, and size of the conduit or cable. The ChargePoint Concrete Mounting Template (CMT) accommodates service wiring through the flare, conduit, or locally appropriate wiring method.

Note: All wiring and conduit is supplied by the contractor unless otherwise indicated.

Note: It is possible to pre-install Express 280 charging stations as standalone initially and pair them at a later date, if desired. In this case, install the DC and Ethernet conduit and run a pull rope through the conduit before landing the charging stations. Contact ChargePoint for instructions to pair two charging stations when ready.

Upstream Components

Charging stations are considered continuous load devices (EVs draw maximum load for long durations). Therefore, electrical branch circuits to EV chargers must be sized at 125% of the load on each leg of a 3-phase panel for North America installations in accordance with National Electric Code requirements. For other regions, refer to local code.

When planning multiple EV charging stations, it is best practice to segment non-continuous and continuous loads, with all branch circuits for EV charging on a dedicated electrical panel assembly with adequate circuit breakers. When sizing new electrical panels dedicated for EV charging, all branch circuits must support continuous load.

Each Express 280 requires a service panel breaker as follows:

Nominal Voltage	Max AC Current	Circuit Breaker Size
480 VAC (NA)	100 A	125 A (125% continuous load required for North America)

The Express 280 does not contain an internal breaker but recommended Kilo Amps Interrupt Current (KAIC) rating is not to exceed 65 kA.



CAUTION: The Express 280 charging station is tested to IEC 61000-4-5, Level 5 (6 kV @ 3000 A) standards. In geographic areas that experience frequent thunderstorms, supplemental surge protection must be installed at the service panel to guard against product damage.

Transformer Configuration

Refer to the following tables to configure electrical service.

Input Rating	480 VAC, 3-phase, 96 A, 60 Hz
Electrical Service Configuration	277/480 4 wire WYE*
Product Connection	3-phase 480 plus ground (neutral not required)
Harmonic Current Rating	Factor of 4 or higher is recommended

*Delta (floating or grounded) is not supported.

Note: A 3-phase autotransformer with a grounded center point can be used for installation as long as the impedance of the autotransformer is less than 15% of the charging station impedance at rated power.

Input to output voltage step down factor will be relatively small to allow for lower input impedance, for example, 600V AC to 480V AC, 480V AC to 400V AC etc but not from medium voltages to 3-phase rated voltage.

Note the following examples:

- For Express 280 with 80 kW output power, ChargePoint recommends a 100 kVA transformer.
- For a paired Express 280 with overall 160 kW output power, ChargePoint recommends a 200 kVA transformer.

Contact ChargePoint before installing transformers with higher capacity.

AC Disconnect Switch

A local AC disconnect switch, separate from the shunt trip wiring, is recommended to be installed between each charging station and the electrical panel. This is especially important if the main electrical panel or utility room is distant, out of line of sight, or has restricted access. Refer to disconnect switch requirements per NEC Article 625, “Electric Vehicle Charging and Supply Equipment Systems”.



WARNING: If service is performed on either Paired charging station, both stations must be powered off at their AC disconnect switches and locked out/tagged out for safety.

Do not install a DC disconnect between Paired charging stations.

Residual Current Device (RCD) Use

The use of an RCD is not recommended. Using RCDs can create nuisance tripping, especially during transient conditions such as power restoration, line surge, line dips, or phase loss.

To reduce the risk of shock, the charging station provides:

- Galvanic (reinforced) isolation between the AC input and DC output. Current does not flow to earth ground, even in cases such as charge cable damage.

- An output isolation monitor interrupter (IMI).

If the isolation level is compromised, charging is halted or prevented from starting and the output de-energized. The isolation monitor operates continuously during charging to ensure the output is always galvanically isolated. UL 2231-1 requires that an isolation monitor interrupter (IMI) is provided in the product and evaluated during operation as part of certification testing.

Although RCD/GFCI use is required in mode 1,2,3 AC charger installations, neither UL nor IEC mandate an RCD for a permanently installed mode 4 isolated output DC charger.

RCD Settings

For Standalone Express 280 installations where the use of an RCD (RCCB or RCBO) cannot be avoided, use the following settings to minimize nuisance trips:

- Type: A, F or B (type B and F preferred)
- Trip threshold: 500 mA
- Trip delay: 150 ms

If an RCD must be employed for a Paired installation, contact ChargePoint.

Grounding Requirements

- The station must be connected to a grounded, metal, permanent wiring system. A suitably sized grounding conductor must be run with circuit conductors and connected to an equipment-grounding terminal.
- Ensure a grounding conductor that complies with local codes is properly grounded to earth at the service equipment or, when supplied by a separate system, at the supply transformer.

Shunt Trip Wiring (Optional)

The Express 280 provides a set of unpowered (dry) contacts to connect to an optional shunt trip device. These contacts are rated to 240 VAC and 6 amps.

Wiring sections to and from the Express 280 are deactivated when unsafe conditions are detected, such as unintended cover panel removal. A breaker reset is required any time the shunt trip is activated.

If installed, both Express 280 shunt trip should be connected in series on their upstream breakers such that upstream AC power to both units shuts off upon panel removal to remove shock risk inside the Express 280s. All shunt trip behavior is already hard-coded into the Express 280 and has no programmable variables.

Emergency stop devices are governed by local and regional codes and may be required in some sites. If one is required by code or by the site, confirm specifications with your ChargePoint representative.

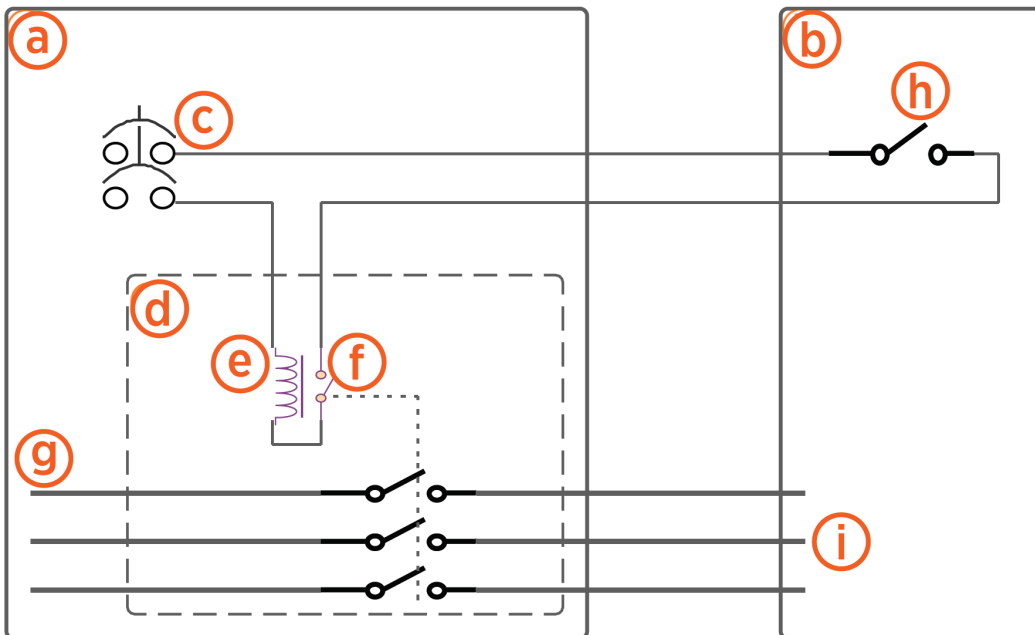

- a. Electrical panel
- b. Express 280
- c. Control voltage supply, maximum 240 VAC
- d. Shunt trip circuit breaker
- e. Shunt trip coil
- f. Auxiliary contacts (closed when main contacts are closed)
- g. 3-phase AC main
- h. Express 280 shunt trip contacts, Normally Open (inside the auxiliary power supply, accessible on field wiring terminal block)
- i. 3-phase Express 280 AC input

Conduit

The outer diameter of conduit must not exceed the sizes called out in the conduit layout drawing below. Conduit stub-ups cannot extend higher than 76.2 mm (3 in) above the surface of the concrete pad.

In regions that do not use conduit, armored cable may be laid in the same configuration to conform to the wire placement as shown in the *Concrete Mounting Template for Express Plus Power Link and Express 250 Guide*. Ensure a length of at least 61 cm (2 ft) is left free above grade at each end to allow the wiring to reach the charging station AC terminals.

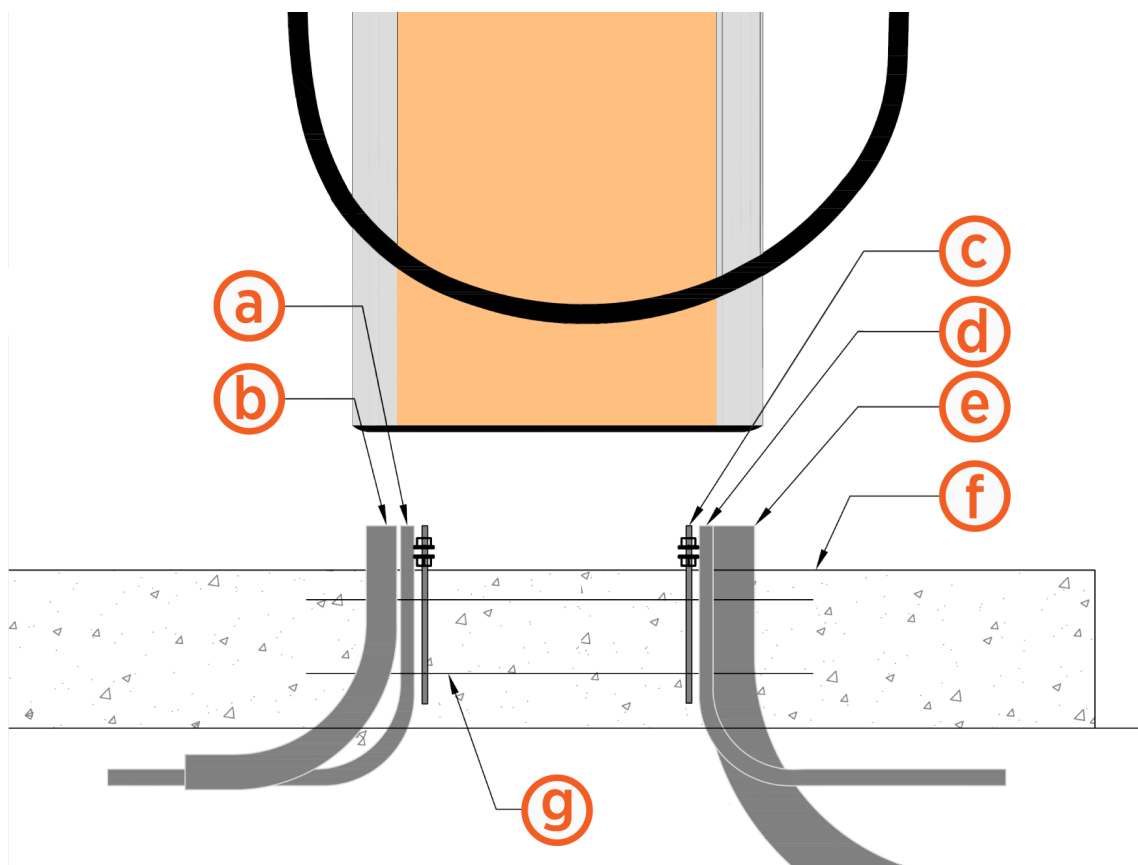

- a. (Optional) Shunt trip conduit: 19.1 mm (3/4 in trade size)
- b. AC conduit: 50.8 mm (2 in trade size)
- c. Anchor bolts
- d. Paired installations only: Ethernet conduit: 19.1 mm (3/4 in trade size)
- e. Paired installations only: DC conduit: 76.2 mm (3 in trade size)
- f. Concrete surface
- g. Concrete Mounting Template (embedded in concrete)

Note: Ensure no bell ends are left on any conduit after all wires are pulled. Bell ends can interfere with station placement.

Note: Depth of conduit or armored cable may vary by site. The image above does not dictate conduit depth, as long as the stub-ups are vertical and placed correctly.

Wiring Requirements for Standalone Stations



IMPORTANT: The AC terminals on the Express 280 accept a maximum wire size of 55 mm² (1/0 AWG) solid or stranded wires. If using a larger gauge wire to accommodate a long run, reduce the wire size at the local external disconnect.

For full product specifications, refer to the *Express 280 Datasheet*. Using that data, ensure that the installation location is equipped with service wiring that supports the station's power requirements:

- Neutral conductor as required by region (a Neutral connection is not required for equipment operation and the terminal is provided for convenience only)
- Shunt trip wiring: size 0.08 to 2.5 mm² (28 to 14 AWG), fine stranded or solid
- AC conductors (L1, L2, L3) and ground per the following specifications:

Voltage Rating	Temperature Rating	Maximum Conductor Size for Terminals
Phase conductors - 600 V	90°C	1/0 AWG
Ground conductor- 600 V	90°C	6 AWG

- AC lugs (x3):
 - Silver plated copper compression lug (2-hole specified for North America); tin plated is acceptable if used with dielectric grease
 - Holes for an M6 (1/4 in) stud at 19 mm (3/4 in) stud hole spacing
 - Maximum width 30 mm (1.18 in)

Additional Wiring Requirements for Paired Stations



IMPORTANT: The DC terminal blocks on the Express 280 can accept a maximum wire size of 120 mm² (4/0 AWG) with 300 kcmil. Check site plans and local code for site-specific requirements.

For stations that will be installed as Paired, follow all AC wiring requirements above as well as the following additional wiring.

Note: Be sure to acquire, or alert the installer to acquire, lugs before visiting the site. Contact ChargePoint in advance if you need help obtaining lugs.

Ethernet wiring for DC:

- Minimum of CAT5e or better
- Outdoor or plenum rated wiring
- Maximum run length of 100 m (328 ft)
- Leave 3.2 m (10.5 ft) of wire above grade at each end
- Field crimp using straight-through pattern 568B

DC conductors (x4):

- 2 positive and 2 negative conductors; 1 positive and 1 negative in each direction
- Copper only, minimum current carrying capacity 200 A
- DC cable run must be continuous, with no joints or splices
- Consult site drawings for site-specific conductor size and length
- Leave 61 cm (2 ft) of each conductor above grade at each end

Voltage Rating	Temperature Rating	Maximum Conductor Size for Terminals	Insulation Type
Phase conductors - 1000 V	90°C	300 kcmil, 1x per pole	XHHW-2
• Ground conductor- 1000 V	90°C	4/0 AWG	XHHW-2

- DC lugs (x4):
 - All lugs must be nickle, tin, or silver plated copper compression (not mechanical) lugs. Nickel plated and used with dielectric grease is recommended.
 - 2-hole lugs, 1 in spacing, 3/8 in hole size, and 1.23 in max tongue width.

When DC conductors are pulled through conduit, label each end of each DC conductor to aid installation as follows:

- “Station 1 A+” on one end and “Station 2 B1+” on the other end
- “Station 1 A-” on one end and “Station 2 B1-” on the other end
- “Station 1 B1+” on one end and “Station 2 A+” on the other end
- “Station 1 B1-” on one end and “Station 2 A-” on the other end

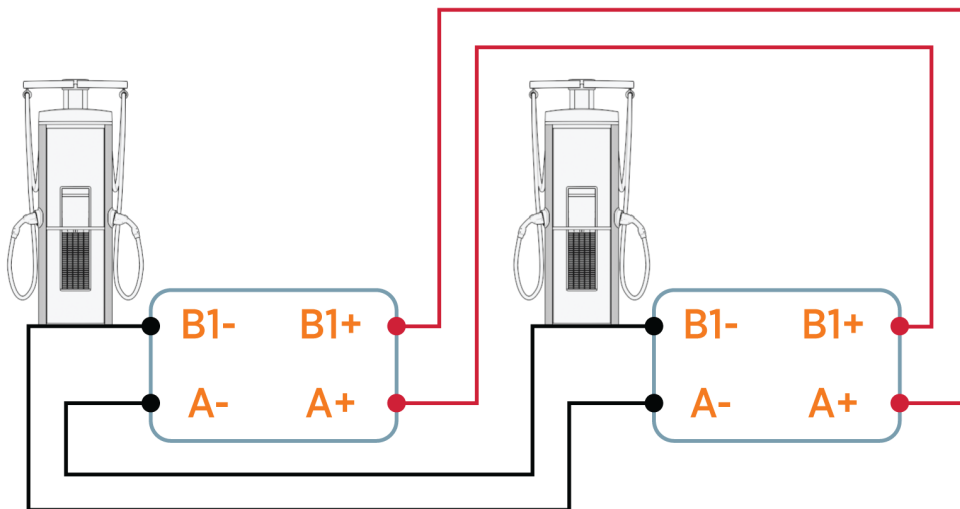

CAUTION: Be sure to connect positive to positive, and negative to negative, on the same wire. Do not reverse the polarity.

Wiring Diagram

GENERAL NOTES

ALL EQUIPMENT SHALL BE INSTALLED AND LABELED IN ACCORDANCE WITH AT LEAST THE 2017 NATIONAL ELECTRICAL CODE AND ALL APPLICABLE REQUIREMENTS OF THE SERVING ELECTRIC UTILITY COMPANY AND THE AUTHORITY HAVING JURISDICTION.

UNDERGROUND CONDUIT SHALL BE SCHEDULE 40 PVC, EXCEPT AS NOTED OTHERWISE ON THE DRAWING. EXPOSED CONDUIT SHALL BE EMT, ENT OR RMC AS REQUIRED FOR THE ENVIRONMENT IN WHICH IT IS INSTALLED.

ALL CONDUCTORS SHALL BE COPPER. ALL OCPDS, CONDUCTORS AND CONDUIT SIZES STATED HERE ARE PROVIDED BY ChargePoint FOR REFERENCE ONLY. SITE SPECIFIC WIRE SIZING SHALL BE PERFORMED BY THE INSTALLATION CONTRACTOR TAKING INTO ACCOUNT LOCAL CONDITIONS AND CODES/ STANDARDS. USE 90°C LUGS TO KEEP ChargePoint'S EQUIPMENT THERMAL RATINGS.







CONTRACTOR SHALL PERFORM GPR AND TAKE ALL NECESSARY PRE-CAUTIONS TO WORK AROUND EXISTING UTILITIES. ALL PPE SHALL BE WORN AT ALL TIMES WHILE WORKING AROUND ENERGIZED EQUIPMENT. CONTRACTOR SHALL HAVE APPROPRIATE LICENSE WITH STATE.



SAMPLE SINGLE LINE SHOWN. SINGLE LINE MAY VARY DEPENDING ON PROJECT REQUIREMENTS AND/OR RESTRICTIONS. SIZE WIRE ACCORDING TO SITE CONDITIONS AND RESTRICTIONS.

ChargePoint RECOMMENDS RIGHT SIZING THE ELECTRICAL GEAR, INSTALLING ADDITIONAL CMT'S, AND CONDUITS FOR FUTURE EVSE STATIONS AND SYSTEM EXPANSION.

NEW WORK KEYNOTES

1. LISTING AGENCY NAMES AND NUMBERS TO BE INDICATED ON ALL ELECTRICAL EQUIPMENT PER NEC 110.3(B).
2. EQUIPMENT MAY OR MAY NOT BE PRESENT IN FINAL DESIGN.
3. NEC 625.43 DISCONNECTING MEANS. FOR EQUIPMENT RATED 60 A OR MORE THAN 150 V TO GROUND, DISCONNECTING MEANS SHALL BE PROVIDED IN ACCORDANCE TO NEC 110.22, 110.25, AND 110.58.

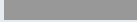
Line Color	Definitions
	480 VAC 3-PHASE CONDUCTORS
	ETHERNET COMMUNICATION CABLE (CAT6 SHIELDED TWISTED PAIR)
	200A, 600-1000 VDC +/- BUS A CONDUCTORS
	200A, 600-1000 VDC +/- BUS B CONDUCTORS
	CHARGING CABLES
	NEW EQUIPMENT
	FUTURE EQUIPMENT

Line Color	Definitions
	OPTIONAL SHUNT TRIP CONDUCTORS
	CELLULAR MODEM INSIDE PROVIDES NETWORK CLOUD CONNECTIVITY

DEFINITIONS

- CPE : CHARGEPOINT CPE280 DISPENSER
- DCS : DISCONNECT SWITCH WHERE REQUIRED PER NEC 110.58
- DP-EV : DEDICATED EVSE ELECTRICAL PANELBOARD
- GND. : GROUND (GROUNDING CONDUCTOR)
- MAX. : MAXIMUM (MAXIMUM SIZE ALLOWED)
- MIN. : MINIMUM (MINIMUM SIZE ALLOWED)
- NEG. : NEGATIVE (NEGATIVE DC CONDUCTOR)
- POS. : POSITIVE (POSITIVE DC CONDUCTOR)
- STP : SHIELDED TWISTED PAIR

Each Express 280 requires a service panel breaker as follows:

Nominal Voltage	Max AC Current	Circuit Breaker Size
480 VAC (NA)	100 A	125 A (125% continuous load required for North America)

Typical Single Line Diagram

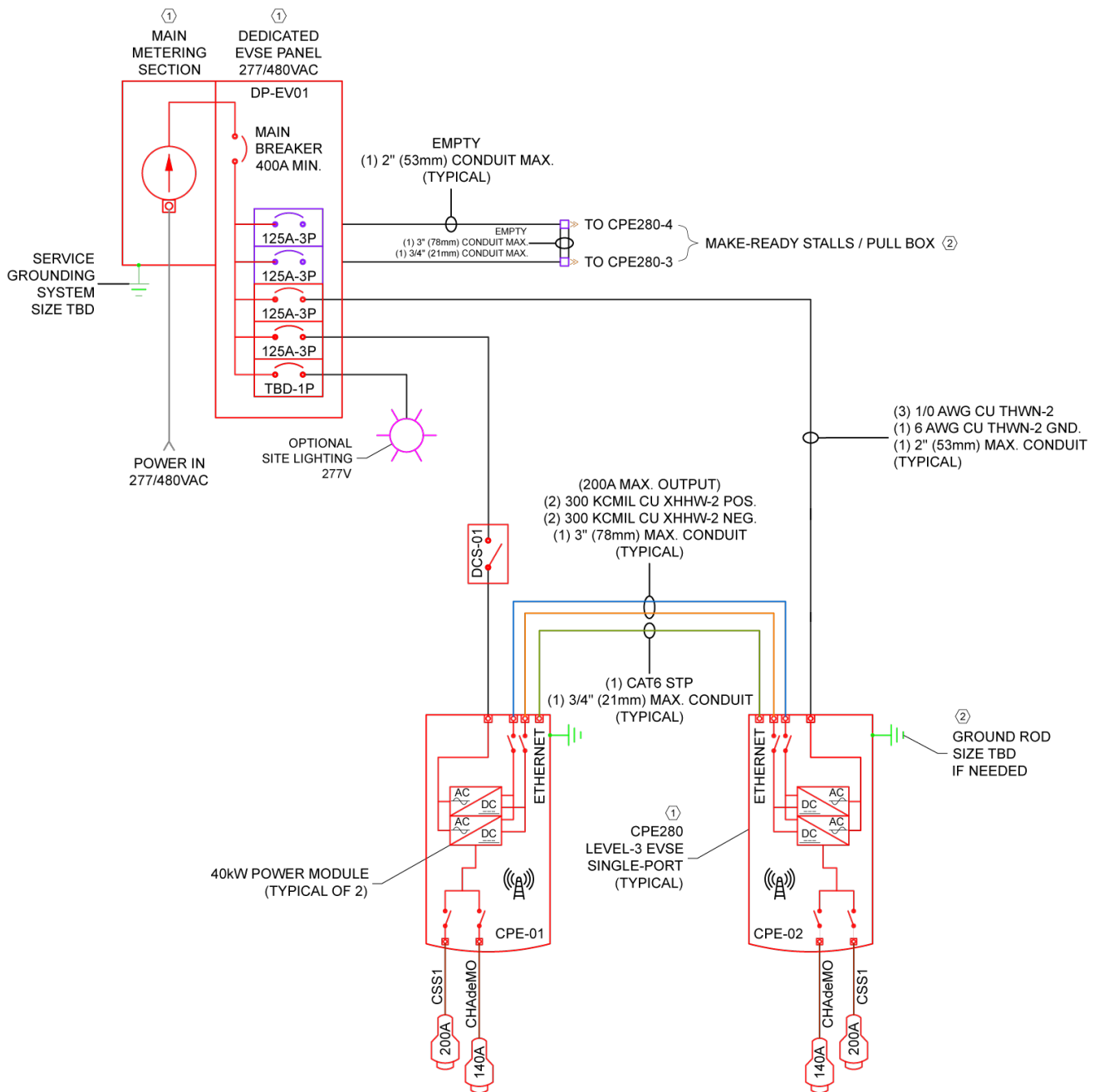

Connectivity 4

A consistently strong cellular signal is needed before installers can activate the vehicle charging station. Weak or sporadic signal can affect crucial aspects of the charging station, including:

- Accuracy in reporting
- Ability for drivers to use the mobile app
- Ability for customer support to troubleshoot problems
- Support for advanced features such as Power Management or Waitlist

A strong signal is also required for the ChargePoint Assure maintenance and management programs.

ChargePoint stations use cellular data connections to reach ChargePoint Cloud Services. This allows secure, PCI-compliant data connections without requiring any other form of internet connectivity at an install site or imposing additional network management responsibilities on a site host.

Each station has its own cellular connection.

Signal Strength and Quality

You must use a cellular signal detection device (such as a Siretta Snyder LTE or equivalent) to take signal strength readings at the exact proposed charging station. If the charging station does not have its own cellular connection, take the signal strength reading at the gateway location.

In North America, ChargePoint products all support LTE bands 2, 4, and 5. The most commonly supported carriers to check during site evaluation are:

- US: AT&T, T-Mobile, Verizon
- Canada: Rogers, Telus, and Bell

For stations using LTE, test the location of every gateway and ensure it meets minimum RSRQ at -12.5 dB or better, for RSRP measured at -90 dBm or better. Refer to the graph for acceptable combinations.

Note: These numbers are all negative, so -70 dBm is stronger than -85 dBm, and -90 dBm is weaker.

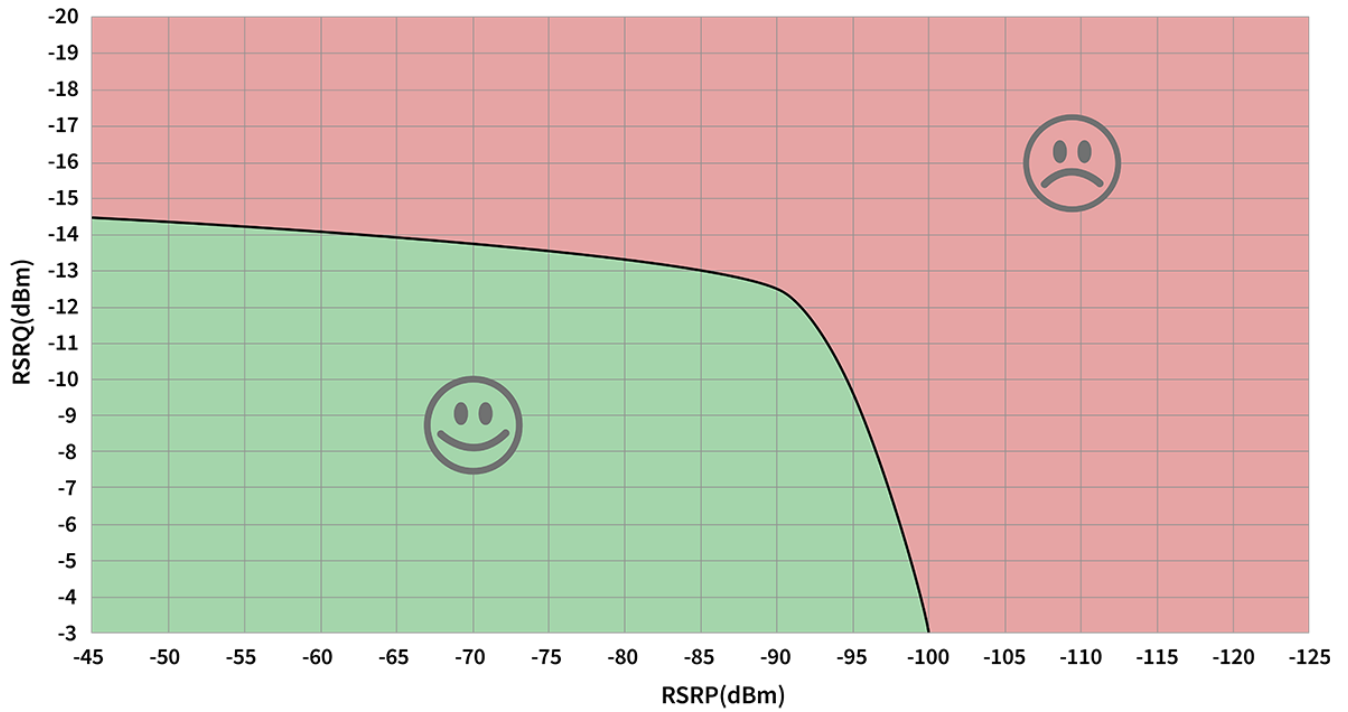

For stations using 3G, test the location of every station and ensure it meets minimum -85 dBm RSSI.

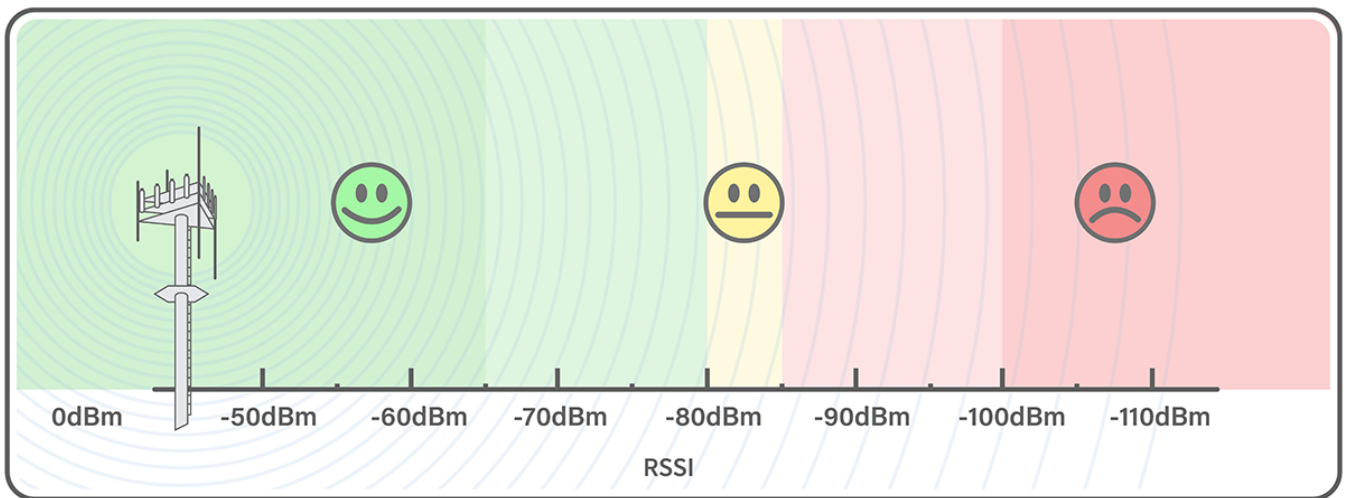

If the signal strength is weaker than this, take cellular readings at the location where any cellular signal booster antennas will be installed. Ensure enough signal exists for that repeater model. Install repeaters to boost the strength of the cellular signals. Repeaters are often required when installing charging stations in an underground garage or enclosed parking structure.

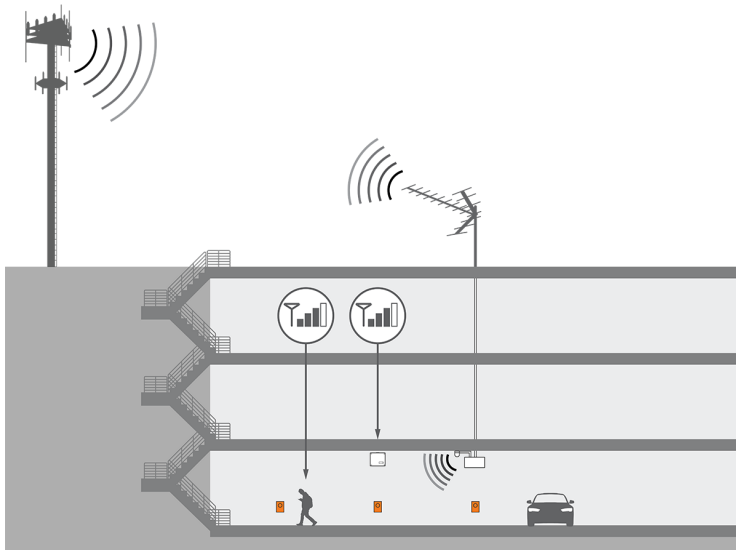
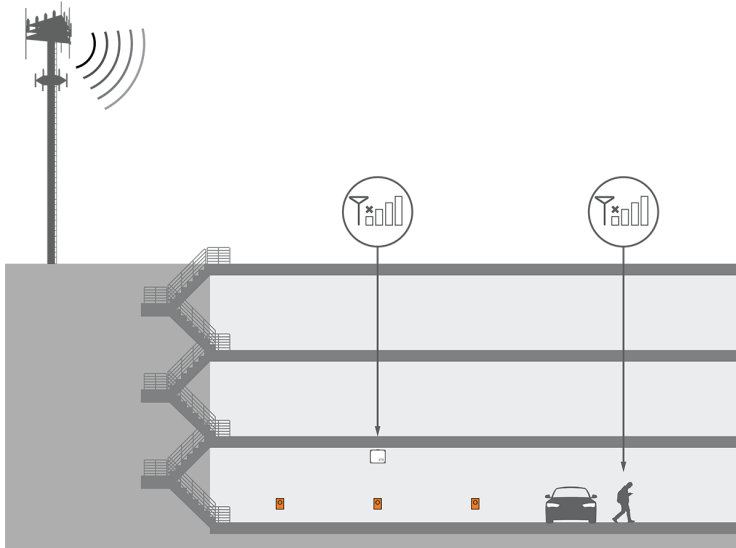

For other regions, or if the site does not have strong signal on these bands, contact your ChargePoint representative for additional solutions.

ChargePoint strongly recommends a consultation with a cellular connectivity specialist before all installations. A consultation can verify:

- Service with a supported carrier on a supported LTE band
- Available signal and local noise levels on applicable bands
- Site changes to correctly meet your needs, both for station bandwidth and other phone coverage for customer or tenant satisfaction

Repeaters

Some sites require repeaters to ensure strong signal to all stations. If a repeater is required, look for a model with these features:

- Specifically LTE compatible on the listed bands
- Multi-carrier
- Multi-band
- Not already dedicated to FirstNet or other first responder-specific networks
- Auto-gain recommended

Note: Do not rely on readings taken with a cell phone when conducting site surveys. Many signal boosters and network extenders may not be compatible with ChargePoint hardware, including certain types of Distributed Antenna Systems (DAS), micro/nano/pico/femto-cells, and carrier- or band-specific signal boosters.

Limited Warranty Information and Disclaimer

The Limited Warranty you received with your charging station is subject to certain exceptions and exclusions. For example, your use of, installation of, or modification to, the ChargePoint® charging station in a manner in which the ChargePoint® charging station is not intended to be used or modified will void the limited warranty. You should review your limited warranty and become familiar with the terms thereof. Other than any such limited warranty, the ChargePoint products are provided "AS IS," and ChargePoint, Inc. and its distributors expressly disclaim all implied warranties, including any warranty of design, merchantability, fitness for a particular purposes and non-infringement, to the maximum extent permitted by law.

Limitation of Liability

CHARGEPOINT IS NOT LIABLE FOR ANY DIRECT, INDIRECT, INCIDENTAL, SPECIAL, PUNITIVE OR CONSEQUENTIAL DAMAGES, INCLUDING WITHOUT LIMITATION LOST PROFITS, LOST BUSINESS, LOST DATA, LOSS OF USE, OR COST OF COVER INCURRED BY YOU ARISING OUT OF OR RELATED TO YOUR PURCHASE OR USE OF, OR INABILITY TO USE, THE CHARGING STATION, UNDER ANY THEORY OF LIABILITY, WHETHER IN AN ACTION IN CONTRACT, STRICT LIABILITY, TORT (INCLUDING NEGLIGENCE) OR OTHER LEGAL OR EQUITABLE THEORY, EVEN IF CHARGEPOINT KNEW OR SHOULD HAVE KNOWN OF THE POSSIBILITY OF SUCH DAMAGES. IN ANY EVENT, THE CUMULATIVE LIABILITY OF CHARGEPOINT FOR ALL CLAIMS WHATSOEVER RELATED TO THE CHARGING STATION WILL NOT EXCEED THE PRICE YOU PAID FOR THE CHARGING STATION. THE LIMITATIONS SET FORTH HEREIN ARE INTENDED TO LIMIT THE LIABILITY OF CHARGEPOINT AND SHALL APPLY NOTWITHSTANDING ANY FAILURE OF ESSENTIAL PURPOSE OF ANY LIMITED REMEDY.

FCC Compliance Statement

This equipment has been tested and found to comply with the limits for a Class A digital device pursuant to Part 15 of the FCC Rules. These limits are designed to provide reasonable protection against harmful interference when the equipment is operated in a commercial environment. This equipment generates, uses, and can radiate radio frequency energy and, if not installed and used in accordance with the manufacturer's instruction manual, may cause harmful interference with radio communications. Operation of this equipment in a residential area is likely to cause harmful interference, in which case, you will be required to correct the interference at your own expense.

Important: Changes or modifications to this product not authorized by ChargePoint, Inc., could affect the EMC compliance and revoke your authority to operate this product.

Exposure to Radio Frequency Energy: The radiated power output of the 802.11 b/g/n radio and cellular modem (optional) in this device is below the FCC radio frequency exposure limits for uncontrolled equipment. The antenna of this product, used under normal conditions, is at least 20 cm away from the body of the user. This device must not be co-located or operated with any other antenna or transmitter by the manufacturer, subject to the conditions of the FCC Grant.

ISED (formerly Industry Canada)

This device complies with the licence-exempt RSS standard(s) of Innovation, Science and Economic Development Canada (ISED). Operation is subject to the following two conditions: (1) this device may not cause interference, and (2) this device must accept any interference, including interference that may cause undesired operation of the device.

Cet appareil est conforme aux flux RSS exemptés de licence d'Innovation, Sciences et Développement économique Canada (ISDE). L'exploitation est autorisée aux deux conditions suivantes : (1) l'appareil ne doit pas produire de brouillage, et (2) l'utilisateur de l'appareil doit accepter.

Radiation Exposure Statement: This equipment complies with the IC RSS-102 radiation exposure limits set forth for an uncontrolled environment. This equipment should be installed and operated with a minimum distance of 20 cm between the radiator and your body.

Énoncé d'exposition aux rayonnements: Cet équipement est conforme aux limites d'exposition aux rayonnements ioniques RSS-102 Pour un environnement incontrôlé. Cet équipement doit être installé et utilisé avec un Distance minimale de 20 cm entre le radiateur et votre corps.

FCC/IC Compliance Labels

Visit chargepoint.com/labels



chargepoint.com/support

75-001539-01 r1