

# Terra AC wallbox UL

## 40/80 A



The Terra AC wallbox is the superior electric vehicle charger, delivering high-value quality, futureproof flexibility, and advanced safety and protection. With connectivity and smart functionality, the Terra AC wallbox is built to adapt to deliver the most optimized charge today and into the future. Convenient destination charging that integrates seamlessly into everyday life.

Product information	
Charging type	Mode 3 charging, level 2
Input / output power rating and current	9.6 kW / 40 A, 19.2 kW / 80 A
Input / output voltage	208 / 240 Vac, 50 / 60 Hz
Network type	TT, TN
Cable type / Cable storage	Type 1 cable , 25 ft (7.6 m) Cable is wrapped around charger and front holster inlet
Protection	Overcurrent, overvoltage, undervoltage, CCID20, integrated surge protection
Overvoltage category	III
Energy metering	Revenue grade energy meter Class B (±2%)
Mobile communication with nano SIM socket	4G, LTE, WCDMA
Available configurable contacts	1 input, 1 output
User interface	
Connectivity	Ethernet (RJ45) with daisy-chain Ethernet option, Wifi, Bluetooth, Modbus RTU RS485, Modbus TCP/IP, 4G
User authentication	ABB RFID card (1 card included) or ChargerSync™ app or portal
User interface / Installer interface	ChargerSync™ app or portal / TerraConfig app and portal for setup
Communication protocols	OCPP 1.6, Modbus RTU RS485 (energy meter or local controller connection), Modbus TCP/IP (local controller connection)
Status indication	5 LED's
Configuration	
Software update	OCPP 1.6, ChargerSync™ portal or app, Terraconfig app
Control and configuration	OCPP 1.6, ChargerSync™ portal or app, Terraconfig app, display wakeup functionality via touch, current limit by rotary switch
General characteristics	
IP and IK rating	IP65, IK10
NEMA enclosure type	NEMA 4
Operating altitude	4000 m
Operating temperature range	-30 ... +55 °C (derating may apply)
Storage temperature range	-40 ... +80 °C
Mounting	Wall or floor using a pedestal
Weight	13 kg
Certification and standards	
Safety standards	UL 2594, UL 2231-1, UL 2231-2, UL 1998, CSA C22.2. NO.280
Codes and standards	FCC Part 15 Class B ENERGY STAR
Certification	SGS
Warranty	24 months

For more information please contact:

### ABB E-mobility

Heertjeslaan 6  
2629 JG Delft  
The Netherlands  
Phone: +31 88 440 4600  
E-mail: info.evi@nl.abb.com

[e-mobility.abb.com](http://e-mobility.abb.com)

—  
INSTALLATION MANUAL

# Terra AC wallbox UL

## 40/80 A

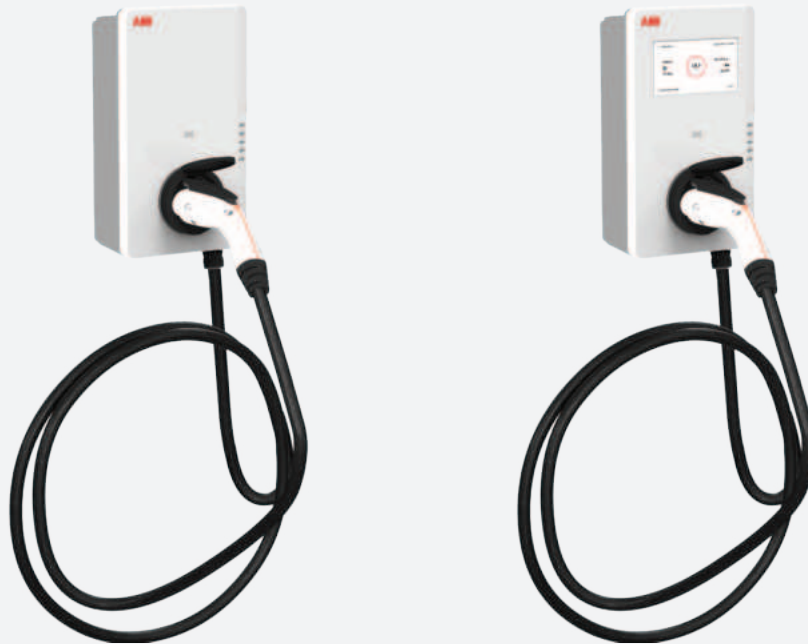



# Table of contents

**04 – 05****About this document**

- Function of this document
- Target group
- How to use this document
- General symbols and signal words
- Related documents
- Abbreviations
- Terminology

**06 – 08****Safety**

- Liability
- Required qualifications for the installation engineer
- Personal protective equipment
- FCC compliance statement
- Industry Canada compliance statement
- General safety instructions
- Signs on the EVSE
- Discard the EVSE or parts of the EVSE
- Safety instructions for earthing
- Special safety instructions
- Additional important safety instructions

**09 – 15****Description**

- Intended use
- External components
- Product label
- LED indicators
- Display (for display models only)
- Internal components

**16 – 17****Installation**

- In the box
- Required tools for installation
- General installation procedure
- Unpack the EVSE

**18****Site preparation**

- Select the site
- Prepare the site
- Space requirements for installation

**19 – 20****Mechanical installation**

- General mechanical installation procedure
- Prepare the holes for the mounting screws
- Move the holster inlet
- Install the mounting screws

21 – 27

**Electrical installation**

- General electrical installation procedure
- Insert the AC input conduit
- Insert the AC input cable and Install the cold-pressed terminal for PE
- Install the mechanical lugs for L1, L2, option 1
- Install the cold-pressed terminal for L1, L2, option 2
- Connect the AC input wires
- Insert the Ethernet conduit
- Insert and connect the Ethernet cable
- Insert the smart meter communication conduit
- Insert and connect the wires for the smart meter communication
- Insert the Nano-M2M SIM card
- Rotary switch set current limit

28

**Commissioning**

- General commissioning procedure
- Energize the EVSE
- Set up the EVSE
- TerraConfig app to do the commissioning

29 – 31

**Troubleshooting**

- Troubleshooting procedure
- Troubleshooting table
- De-energize the EVSE

32 – 36

**Technical data**

# About this document

## Function of this document

The document is only applicable for this EVSE (Terra AC), including the variants and options listed in chapter [Technical data](#), page 32. The EVSE from here on in the document is referred to as the EVSE. The document gives the information that is necessary to do these tasks:

- Installation
- Commissioning











## Target group

The document is intended for qualified installation engineers. For a description of the required qualifications, refer to section [Required qualifications for the installation engineer](#), page 6.

## How to use this document

1. Make sure that you know the structure and contents of this document.
2. Read the safety chapter and make sure that you know all the instructions.
3. Do the steps in the procedures fully and in the correct sequence.
4. Keep the document in a safe location that you can easily access. This document is a part of the EVSE.

**Table 1: General symbols and signal words**

Signal word	Description	Symbol
Danger	If you do not obey the instruction, this can cause injury or death	Refer to Table 6, page 7
Warning	If you do not obey the instruction, this can cause injury	Refer to Table 6, page 7
Caution	If you do not obey the instruction, this can cause damage to the EVSE or to property	
Note	A note gives more data, to make it easier to do the steps, for example	
-	Information about the condition of the EVSE before you start the procedure	
-	Requirements for personnel for a procedure	
-	General safety instructions for a procedure	
-	Information about spare parts that are necessary for a procedure	
-	Information about support equipment that is necessary for a procedure	
-	Information about supplies (consumables) that are necessary for a procedure	
-	Make sure that the power supply to the EVSE is disconnected	
-	Electrotechnical expertise is required, according to the local rules	
-	Alternating current supply	



**Note:** It is possible that not all symbols or signal words are present in this document.

**Table 2: Related documents**

Document name	Target group
Product data sheet	All target groups
Installation manual	Qualified installation engineer
User manual	Owner
Declaration of conformity by UL / cUL	All target groups

**Table 3: Abbreviations**

Abbreviation	Definition
AC	Alternating current
CAN	Controller area network
CPU	Central processing unit
DC	Direct current
EMC	Electromagnetic compatibility
EV	Electric vehicle
EVSE	Electric vehicle supply equipment
MID	Measuring Instruments Directive
NFC	Near field communication
NoBo	Notified body
OCCP	Open charge point protocol
PE	Protective earth
PPE	Personal protective equipment
RFID	Radio-frequency identification

**Table 4: Terminology**

Term	Definition
Network operating center of the manufacturer	Facility of the manufacturer to do a remote check on the correct operation of the EVSE
Cabinet	Enclosure of the EVSE, including the components on the inside
Contractor	Third party that the owner or site operator hires to do engineering, civil and electrical installation work
Grid provider	Company that is responsible for the transport and distribution of electricity
Local rules	All rules that apply to the EVSE during the entire lifecycle of the EVSE. The local rules also include the national laws and regulations
Open charge point protocol	Open standard for communication with charge stations
Owner	Legal owner of the EVSE
Site operator	Entity that is responsible for the day-to-day control of the EVSE. The site operator does not have to be the owner
User	Owner of an EV, who uses the EVSE to charge the EV



**Note:** It is possible that not all terms are present in this document.

# Safety

## Liability

The manufacturer is not liable to the purchaser of the EVSE or to third parties for damages, losses, costs or expenses incurred by the purchaser or third parties if any target group mentioned in the related documents does not obey the rules below:

- Obey the instructions in the [Table 4, page 5](#)
- Do not misuse or abuse the EVSE
- Only make changes to the EVSE, if the manufacturer approves in writing of the changes

This EVSE is designed to be connected to and to communicate information and data via a network interface. It is the sole responsibility of the owner to provide and continuously ensure a secure connection between the EVSE and the network of the owner or any other network.

The owner shall establish and maintain any appropriate measures (such as - but not limited to - the installation of firewalls, application of authentication measures, encryption of data and installation of anti-virus programs) to protect the EVSE, the network, its system and the interface against any kind of security breaches, unauthorized access, interference, intrusion, leakage and/or theft of data or information.

The manufacturer is not liable for damages and/or losses related to such security breaches, any unauthorized access, interference, intrusion, leakage and/or theft of data or information.



## Required qualifications for the installation engineer

- The qualified installation engineer fully knows the EVSE and its safe installation
- The installation engineer is qualified according to the applicable local rules to do the work
- The qualified installation engineer obeys all local rules and the instructions in the installation manual
- It is the responsibility of the owner of the EVSE to make sure that all qualified installation engineers obey the local rules, the installation instructions, and the specifications of the EVSE

**Table 5: Personal protective equipment**

Symbol	Description
	Protective clothing
	Safety gloves
	Safety shoes
	Safety glasses

## FCC compliance statement



**Caution:** Changes or modifications not expressly approved by the party responsible for compliance could void the user's authority to operate the equipment.



**Note:** This equipment has been tested and found to comply with the limits for a Class B digital device, pursuant to part 15 of the FCC Rules. These limits are designed to provide reasonable protection against harmful interference in a residential installation. This equipment generates, uses and can radiate radio frequency energy and, if not installed and used in accordance with the instructions, may cause harmful interference to radio communications. However, there is no guarantee that interference will not occur in a particular installation. If this equipment does cause harmful interference to radio or television reception, which can be determined by turning the equipment off and on, the user is encouraged to try to correct the interference by one or more of the following measures:

- Reorient or relocate the receiving antenna
- Increase the separation between the equipment and receiver
- Connect the equipment into an outlet on a circuit different from that to which the receiver is connected
- Consult the dealer or an experienced radio/TV technician for help

**Industry Canada compliance statement**

This device contains licence-exempt transmitter(s)/ receiver(s) that comply with Innovation, Science and Economic Development Canada’s licence-exempt RSS(s). Operation is subject to the following two conditions:

- This device may not cause interference
- This device must accept any interference, including interference that may cause undesired operation of the device

**RF exposure statement**

This equipment complies with IC radiation exposure limits set forth for an uncontrolled environment. This equipment should be installed and operated with minimum distance 20cm between the radiator and your body.

**General safety instructions**

- This document, the related documents and the warnings included do not replace your responsibility to use your common sense when you do work on the EVSE
- Only do the procedures that the related documents show and that you are qualified for
- Obey the local rules and the instructions in this manual. If the local rules contradict the instructions in this manual, the local rules will apply

If and to the extent permitted by law, in case of inconsistency or contradiction, between any requirements or procedure contained in this document and any such local rules, obey the stricter between the requirements and procedures specified in this document and the local rules.

Table 6: Signs on the EVSE

Symbol	Risk type
	General risk
	Hazardous voltage that gives risk of electrocution
	Risk of pinching or crushing of body parts
	Rotating parts can cause a risk of entrapment
	PE
	Sign that means that you must read the manual before you install the EVSE
	Waste from electrical and electronic equipment





**Note:** It is possible that not all symbols are present on the EVSE.

### Discard the EVSE or parts of the EVSE

Incorrect waste handling can have a negative effect on the environment and human health due to potential hazardous substances. With the correct disposal of this product, you contribute to reuse and recycling of materials and protection of the environment.

- Obey the local rules to discard parts, packaging material or the EVSE
- Discard electrical and electronic equipment separately in compliance with the WEEE - 2012/19/EU Directive on waste of electrical and electronic equipment
- As the symbol of the crossed out wheeled-bin on your EVSE indicates, do not mix or dispose the EVSE with your household waste, at the end of use. Instead, hand the EVSE over to your local community waste collection point for recycling
- For more information, contact the Government Waste-Disposal department in your country

### Safety instructions for earthing

Table 7: Preliminary requirements



- Make sure that the EVSE is connected to a grounded, metal, permanent wiring system, or an equipment-grounding conductor must be run with the circuit conductors and connected to the equipment grounding terminal or lead on the product
- Make sure that the connections to the EVSE comply with all applicable local rules

### Special safety instructions (North America)



**Warning:** Obey the basic precautions for electric products, including the instructions in this section.



**Caution:** To reduce the risk of fire, connect this EVSE only to a circuit provided with, see [Table Circuit breaker rating, page 35](#), maximum branch circuit overcurrent protection in accordance with the National Electrical Code, ANSI/NFPA 70.

- Read all the instructions before you use this EVSE
- Make sure that adults supervise this EVSE is when it is used around children
- Do not put fingers into the EV connector
- Do not use this product if the flexible power cord or EV charge cable is frayed, has broken insulation, or any other signs of damage
- Do not use this EVSE if the enclosure or the EV connector is broken, cracked, open, or shows any other indication of damage
- Install an insulated grounding conductor that is identical in size, insulation material, and thickness to the grounded and ungrounded branch-circuit supply conductors, except that it is green with or without one or more yellow stripes, as part of the branch circuit that supplies the EVSE
- Connect the grounding connector of the previous bullet point to earth at the EVSE or, when supplied by a separately derived system, at the supply transformer
- For the AC power input wiring installation, refer to section [Insert the AC input conduit, page 22](#)
- For the torque requirements for the screws of the terminal block for the AC power, refer to chapter [Technical data, page 34](#)



**SAVE THESE INSTRUCTIONS**

---

# Description

## Intended use

The EVSE is intended for the AC charging of EVs. The EVSE is intended for indoor or outdoor use.

The technical data of the EVSE must comply with the properties of the electrical grid, the ambient conditions and the EV. Refer to chapter [Technical data](#), page 32. Only use the EVSE with accessories that the manufacturer provides or that obey the local rules.

The EVSE AC input is intended for a hardwired installation that complies with the applicable national regulations.



### **Danger:**

General risk

- If you use the EVSE in any other way than described in the related documents, you can cause death, injury and damage to property
- Use the EVSE only as intended



## External components

### Overview of the EVSE, outside

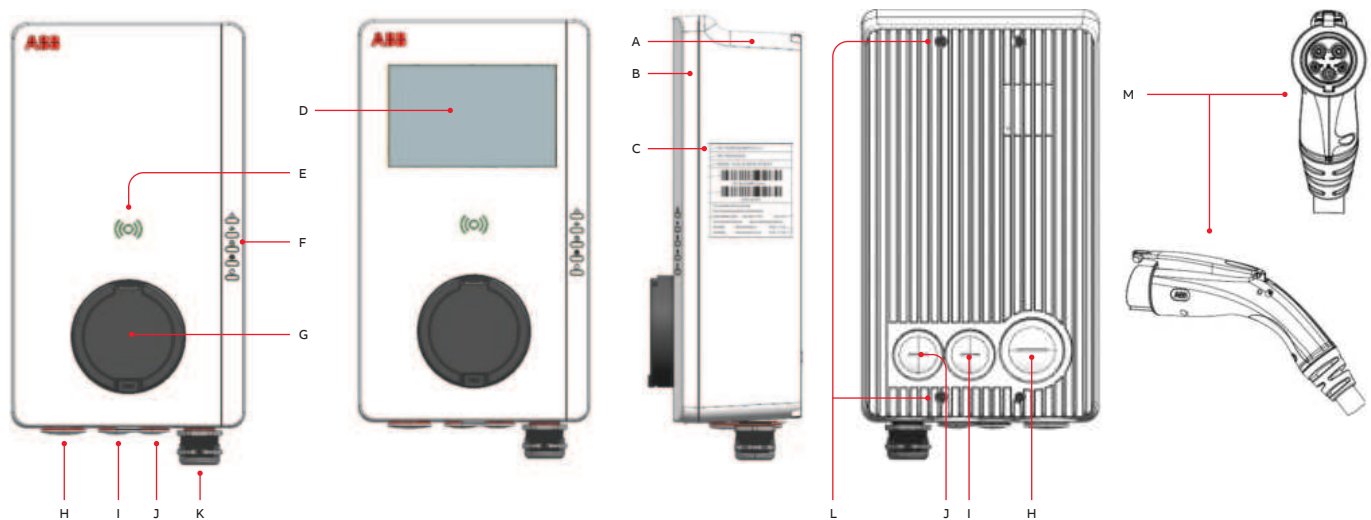

**Table 8: Overview of the parts and their function**

Label	Part	Function
A	Enclosure	To reduce the accessibility of unqualified persons to the inside of the EVSE
B	Front cover	To prevent a user to access the installation and maintenance parts of the EVSE
C	Product label	To show the identification data of the EVSE. Refer to section <a href="#">Product label</a> , page 11
D	Display (optional)	To show the status of the EVSE and the charge session
E	RFID reader	To authorize the start or stop of a charging session with an RFID card
F	LED indicators	To show the status of the EVSE and the charge session
G	Holster inlet	To store the charge connector
H	Conduit enclosure plug	For the AC input cable
I	Conduit enclosure plug	For the Ethernet cable
J	Conduit enclosure plug	For the smart meter connections
K	Charge cable	Cable connection to EV
L	Mounting points	To mount EVSE
M	Charge connector	Cable connection to EV, SAE J1772, type 1



**Note:** The illustration shows the EVSE model with and without a display. For more data about the display, refer to section [Display \(for display models only\)](#), page 13.

## Product label

A 

B 

C 

D 

E 

F 

G 

H 

I 

J 

K 

[www.abb.com](http://www.abb.com)

Label	Part
A	Brand
B	Serial number
C	Part number of the EVSE
D	Product model number
E	Barcode with the serial number of the EVSE
F	Barcode with the part number of the EVSE
G	Power rating of the EVSE / NEMA enclosure type / ambient temperature
H	Mass of the EVSE
I	Address of the manufacturer
J	Reference to the manual
K	Certification

## LED indicators

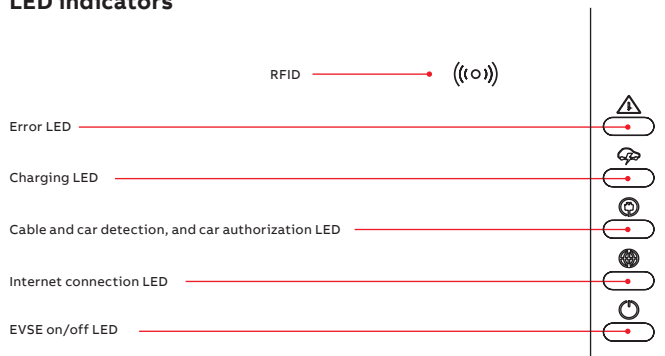

**Table 9: LED indicators and statuses**

	Status of the LED	Status of the EVSE
<b>Error LED</b>	On	Error
	Off	No Error
<b>Charging LED</b>	On	EV is fully charged or has stopped charging
	Off	Not charging
	Flashing	Charging
<b>Cable and car detection, and car authorization LED</b>	On	A car is connected. The connection is authorized
	Off	No car connected
	Flashing	A car is connected, waiting for authorization
<b>Internet connection LED</b>	On	Connected to the internet
	Off	Not connected to the internet
	Flashing	The internet connection is set up
<b>EVSE on/off LED</b>	On	The EVSE is on
	Off	The EVSE is off
	Flashing	The EVSE is in setup

## Display (for display models only)

Display wakeup functionality via touch or when changing charge status, connect or disconnect cable to EV, preparing to charge and charging.

- Screen dim time = 2 minutes (default value)
- Screen dim time range = 10-300 seconds
- Screen brightness = 100% (default value)
- Screen brightness range = 10-100
- Dime time and brightness are configurable via OCPP 1.6 J

### Boot screen



### Preparing to charge screen

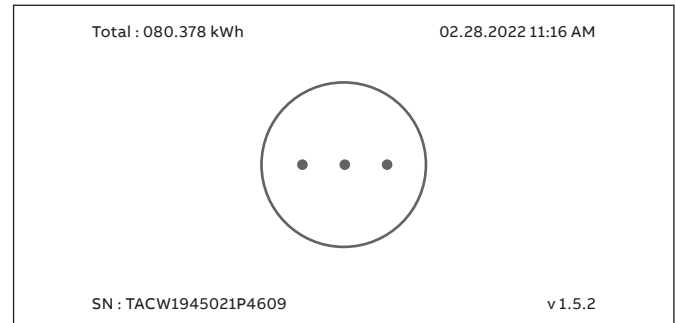

### Charging screen

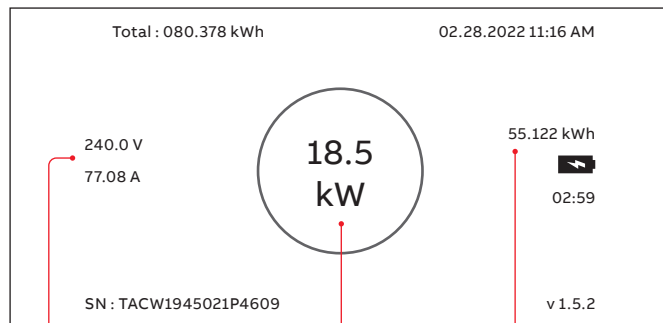

Real-time voltage and current

Real-time active power

Energy delivered and duration of the charge session

### Charging completed screen

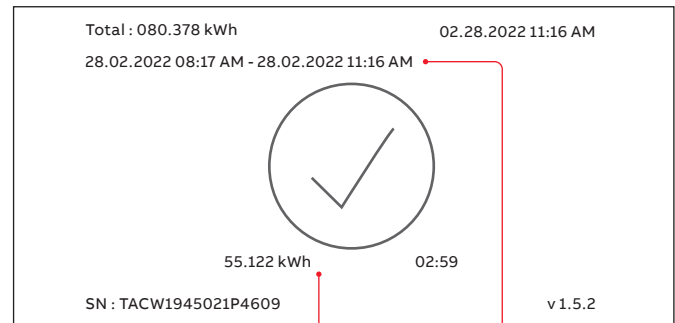

Energy delivered and duration of the charge session

Start and end time

**Fault detected display messages**

Disconnect the charge cable and connect it again

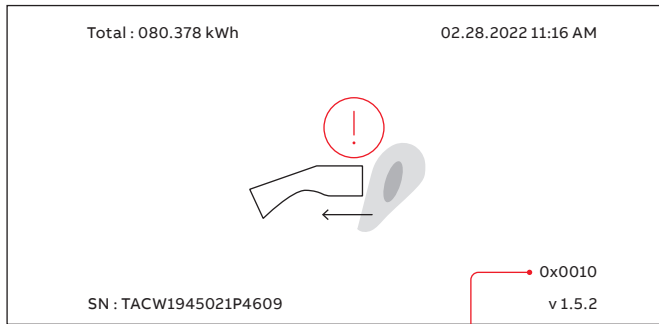

Error code

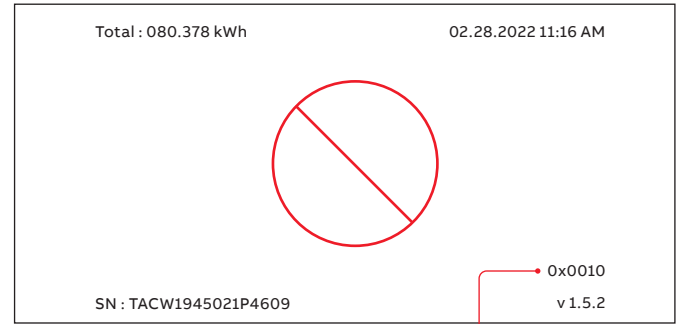
**Contact your service provider:**

Error code

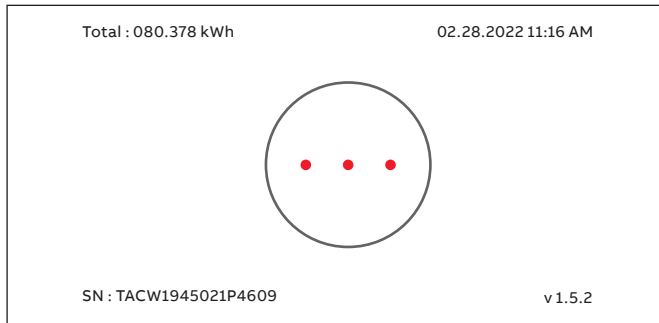
**The EV is not ready for the charge session**

## Internal components

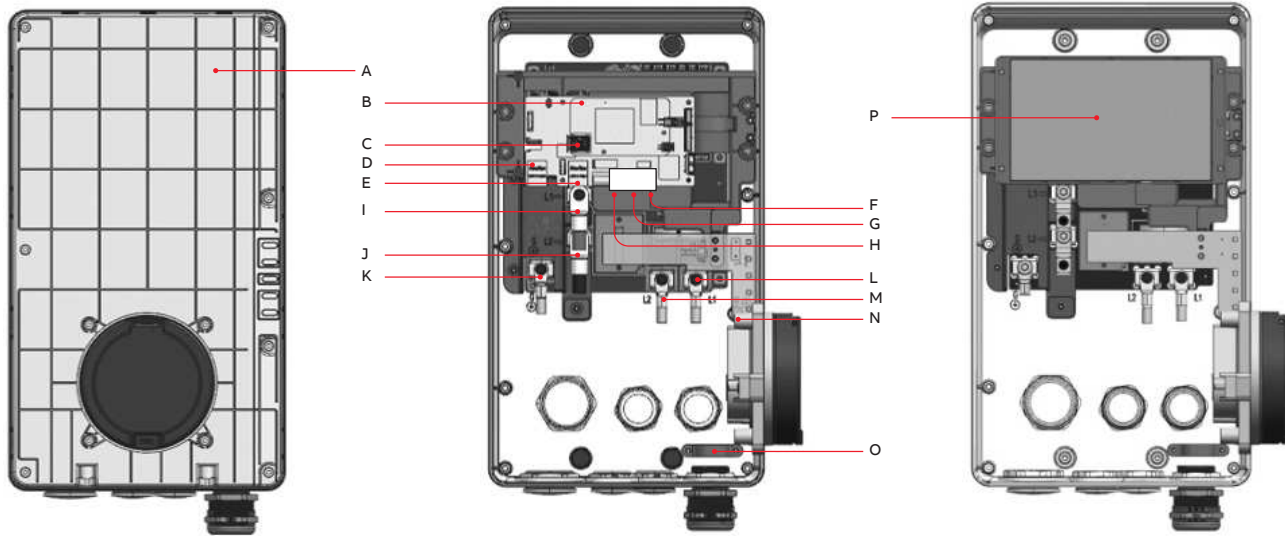

Label	Part	Label	Part
A	Maintenance cover	I	AC input L1
B	Rotary switch set current limit	J	AC input L2
C	Nano-M2M SIM card slot	K	AC input PE
D	Primary Ethernet port RJ45	L	Charge cable L1
E	Secondary Ethernet port RJ45	M	Charge cable L2
F	Configurable output contact	N	Charge cable PE
G	Configurable input contact	O	Charge cable with strain relief
H	Modbus RTU (RS-485)	P	Display

### Load management

Load management makes sure that the available capacity of the building or home is not exceeded. A number of devices share a grid connection, that has a maximum capacity.

The total power demand of the devices that use the grid connection must not exceed the grid capacity.

The load management feature prevents that the system exceeds the grid capacity and prevents damage of the fuses. At times when the current demand is high, the EVSE decreases the output of current. The current will increase again when there is availability on the grid. Also, the load management feature makes sure that the available load is optimally shared.



# Installation

## In the box





Elements	Number of copies
EVSE	1
QSG, ABB Terra AC Wallbox, Ready. Set. Charge	1
RFID card	1
Installation template	1
Anchors 0.39 x 3.14 in (10 x 80 mm)	4
Screws 0.23 x 2.95 in (6 x 75 mm) with silicone washer	4
Mechanical lug	2
Cold pressed ring terminal, L1/L2	2
Cold pressed ring terminal, PE	1
0.23 x 0.314 in (6x8 mm) screw	3
L1-L2 cover	1

## Required tools for installation

T20 security pin Torx driver
Allen wrench set
Tape measure
Power drill
Drill bit, 25/64 in. (10 mm)
Wire cutter
Wire stripper
Crimp tool
Torque driver (50 lbf. in, 5.7. Nm)
Optional Smartphone with Bluetooth
Hamer
Spirit level
Slotted screwdriver
Philips P3 screwdriver

## General installation procedure

**Table 10: Preliminary requirements**

	All required permits to agree with the local rules are granted
	The AC input cable is available
	Tools for installation
	There is no voltage on the AC input cable during the complete installation procedure

### Procedure

1. Unpack the EVSE
2. Prepare the site. Refer to chapter [Site preparation](#), page 18.
3. Do the mechanical installation. Refer to section [General mechanical installation procedure](#), page 19.
4. Do the electrical installation. Refer to section [General electrical installation procedure](#), page 21.
5. Install the cabinet cover.
6. Do the commissioning procedure. Refer to chapter [General commissioning procedure](#), page 28.

### Unpack the EVSE

1. Open the box.
2. Take out the EVSE and including parts like QSG from the box.
3. Remove all packaging material from the EVSE.
4. Discard the packaging material.
5. Make sure that all parts are delivered according to the order. Refer to the order and section [In the box on the previous page](#).
6. Do an inspection of the EVSE and the parts for installation for damage.
7. If you find damage or the parts are not according to the order, contact the local representative of the manufacturer (ABB E-mobility B.V.) refer to section [Manufacturer and contact data at the end of the document](#).

# Site preparation

## Select the site

1. Find a suitable site on a wall. For the specifications of the wall, refer to [Table 13: Requirements for the wall](#) on this page.
2. Make sure that the correct power supply is available. For the power supply specifications, refer to chapter [Technical data](#), page 32.
3. Obey the space requirements. Refer to [Table 12: Space requirements for installation](#) on this page.

## Prepare the site

**Table 11: Preliminary requirements**

☑ ☑ ☑ ☑	The site must be suitable to install the EVSE
------------------	---

## Procedure

1. Make sure that the space and the airflow around the EVSE are sufficient. Refer to [Table 12: Space requirements for installation](#) on this page.
2. Make sure that the correct cables are available at the site:
  - AC input cable. Refer to chapter [Technical data](#), page 32
  - RS485 cable. Refer to chapter [Technical data](#), page 32
  - Ethernet cable. Refer to chapter [Technical data](#), page 32

**Table 13: Requirements for the wall**

Parameter	Specifications
Wall thickness	Minimum 4.72 in (120 mm)
Wall strength	The wall must be serviceable for the items listed below: <ol style="list-style-type: none"> <li>1. The weight of the EVSE. Refer to chapter <a href="#">Technical data</a>, page 32</li> <li>2. The torque for the mounting screws. Refer to chapter <a href="#">Technical data</a>, page 32</li> </ol>
Wall material	The mounting surface must be flat and stable, for example a finished, brick or concrete wall

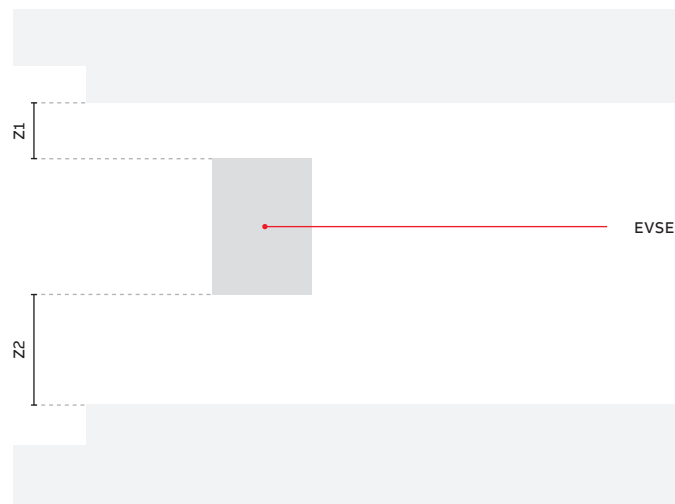

**Table 12: Space requirements for installation**

Parameter	Specification	
	[in]	[mm]
Z1	> 8	> 200
Z2 (indoor use)	18 to 48	450 to 1200
Z2 (outdoor use)	24 to 48	600 to 1200



# Mechanical installation

Table 16: Preliminary requirements

	Spirit level
	Drill
	Installation template
	Anchors for the mounting holes

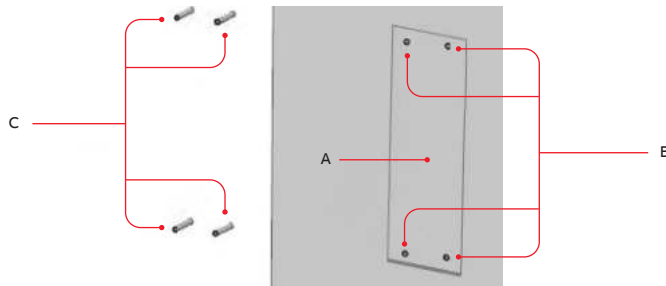

## General mechanical installation procedure



**Note:** The mounting screws and Anchors that are included in the delivery are serviceable for a brick wall. If you want to mount the EVSE on a different type of wall, contact your local representative of the manufacturer, refer to section [Manufacturer and contact data](#) at the end of the document.

## Prepare the holes for the mounting screws

### Procedure

1. Hold the installation template (A) against the wall.
2. Make sure that the installation is level. Use the spirit level.
3. Mark the location for the mounting holes (B).
4. Drill the mounting holes (B).



**Note:** For the diameter of the holes, refer to chapter [Technical data](#), page 32 and section [Required tools for installation](#), page 16.

5. Insert the anchors for the mounting holes (C) in the mounting holes.

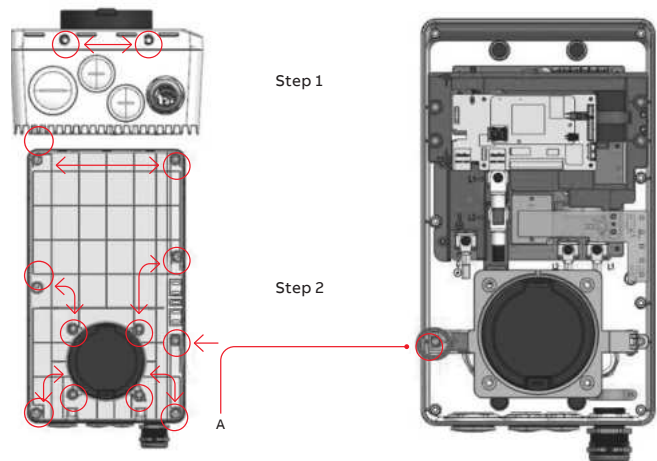

### Move the holster inlet

#### Procedure

1. Remove 2 screws and remove the front cover.
2. Remove 11 screws and remove the maintenance door.
3. Remove the screw (A) on the left side of socket.
4. Move the holster inlet away.

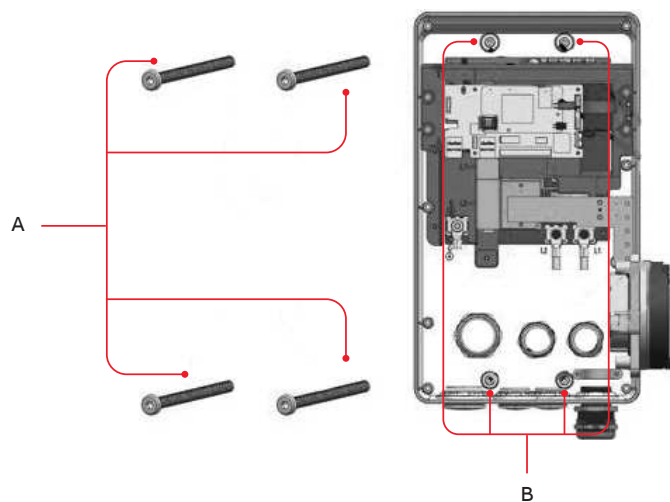

### Install the mounting screws

#### Procedure

1. Install the mounting screws (A) through the holes (B) in the charger.
2. Lock the screws in the anchors. For the specification, refer to chapter [Technical data](#), page 32.

# Electrical installation

Table 21: Preliminary requirements

	The front cover is removed
	The maintenance cover is removed
	The holster inlet is moved away
	The anchors for the mounting screws are installed
	A Nano-M2M SIM card from the provider of the mobile network
	Crimping Tool
	Torque screwdriver
	Screwdriver
	Slotted screwdriver
	Crimping Tool (2AWG)
	Cold-pressed terminal for PE
	Mechanical lugs. Refer to section <a href="#">In the box, page 16</a>
	Cold-pressed terminal for L1, L2. Refer to section <a href="#">In the box, page 16</a>
	Mounting screws
	Smart meter with ModBus RTU interface
	Wire for RS485
	Ethernet cable
	AC input cable (1 phase)
	AC input conduit

## General electrical installation procedure

### Procedure

1. Install the AC input conduit and cable by inserting and connecting them.
2. Install the Ethernet conduit and cable by inserting and connecting them.
3. If necessary, install for the smart meter communication conduit and cable by inserting and connecting them.
4. If you want to use the internet via mobile networks, insert the Nano-M2M SIM card.

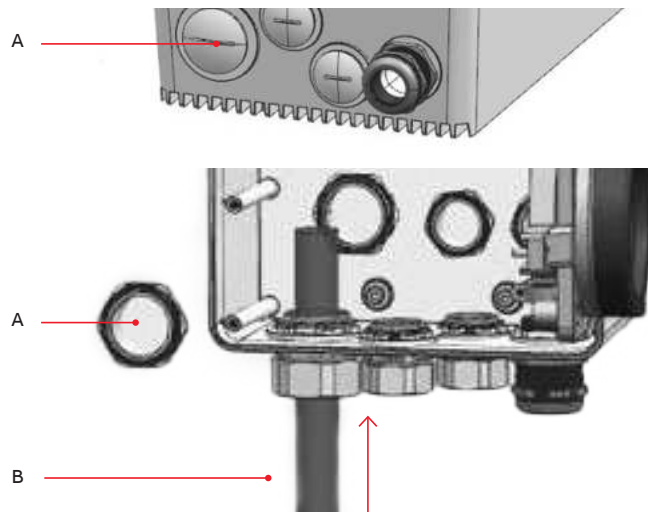

### Insert the AC input conduit

#### Procedure

1. Remove the conduit enclosure plug (A) from the EVSE.
2. Put the AC input conduit (B) through the inlet hole.
3. Install the AC input conduit.

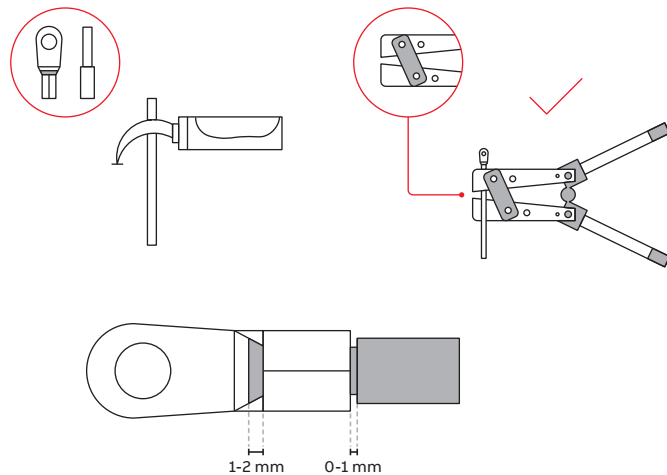

### Insert the AC input cable and install the cold-pressed terminal for PE

#### Procedure

1. Strip the PE wire. For the specification, refer to chapter [Technical data, page 32](#).
2. Insert the PE wire into the cold-pressed terminal to its full insertion length. Crimp the cold-pressed terminal with the correct jaws.
3. Finished.

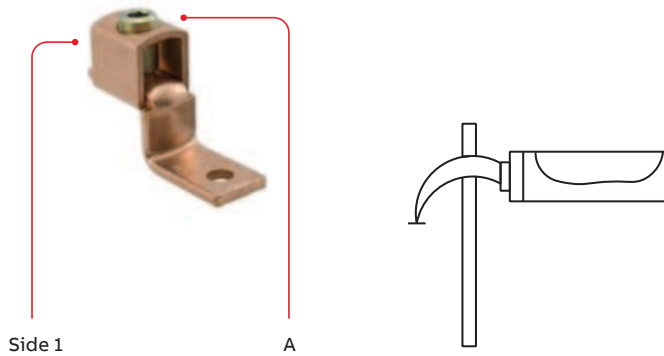

### Install the mechanical lugs for L1, L2, option 1

#### Procedure

1. Loosen the screws (A)
2. Strip the wires. For the specification, refer to chapter [Technical data](#), page 32.
3. Insert the wire into side 1 of the mechanical lug to its full insertion length.
4. Tighten the screws (A) to the correct torque.  
For the specification, refer to chapter [Technical data](#), page 32.

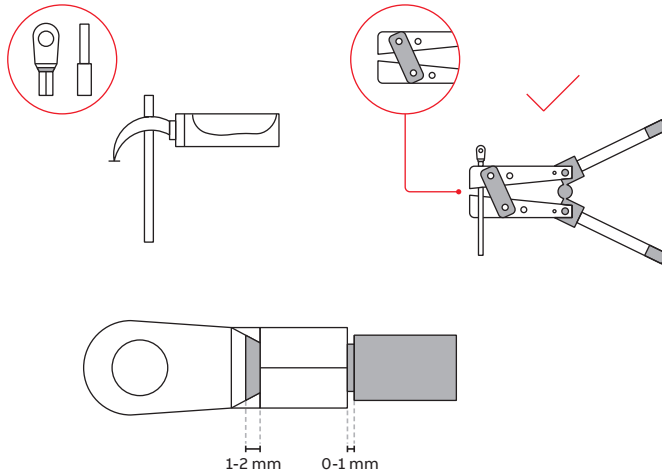

### Install the cold-pressed terminal for L1, L2, option 2

#### Procedure

1. Strip the wires. For the specification, refer to chapter [Technical data](#), page 32.
2. Insert the wire into the cold-pressed terminal to its full insertion length. Crimp the cold-pressed terminal with the correct jaws.
3. Finished.



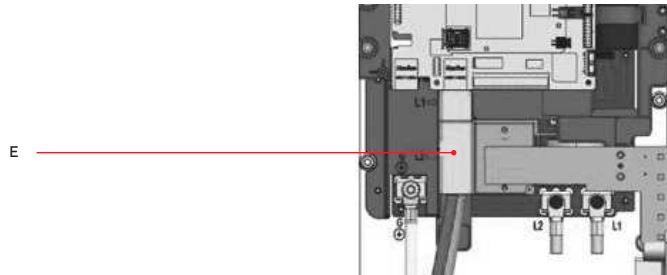
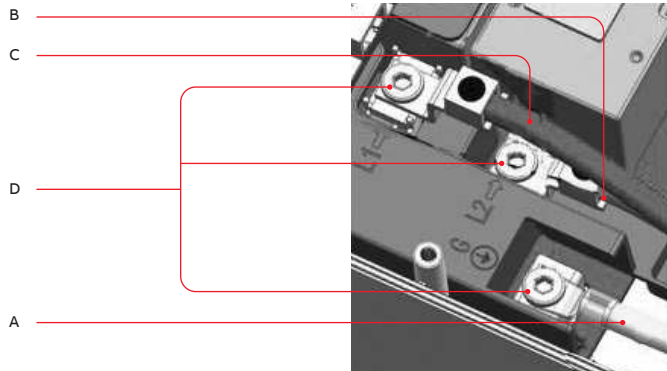

A	Earthing wire
---	---------------

B	L2 AC input wire
---	------------------

C	L1 AC input wire
---	------------------

D	Screws
---	--------

E	Protect cover
---	---------------

### Connect the AC input wires

#### Procedure

1. Connect the below wires:
  - Protective Earth (grounding) wire (A)
  - L2 AC input wire (B)
  - L1 AC input wire (C)
2. Tighten the screws (D) to the correct torque. For the specification, refer to chapter [Technical data](#), page 32.
3. Install the protect cover (E).

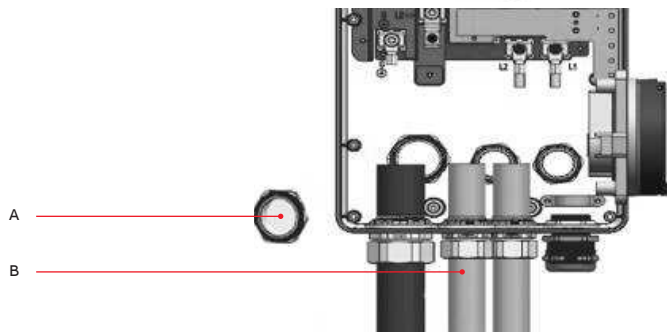
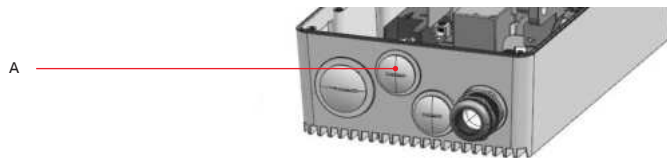

### Insert the Ethernet conduit

#### Procedure

1. Remove the conduit enclosure plug (A) from the EVSE.
2. Put the Ethernet conduit (B) through the cable inlet hole.
3. Install the Ethernet conduit.

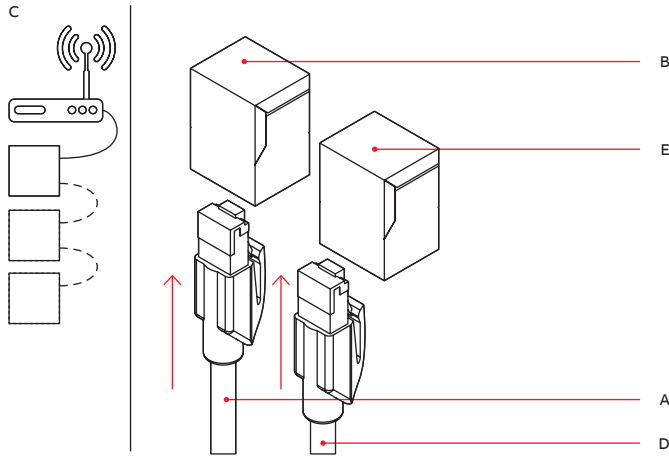

### Insert and connect the Ethernet cable

If your EVSE has two Ethernet connections, it is possible to connect multiple EVSEs in a chain. Only the first EVSE is connected to the PC, router or gateway. Only the Ethernet connection is shared, there is no communication between the EVSEs.

#### Procedure

1. Put the RJ45 plug (A) of the Ethernet cable in the primary Ethernet RJ45 socket (B). Refer to section [Internal components](#), page 15.
2. Connect the Ethernet cable either to a PC, router, or gateway or to the previous EVSE in a chain (C).
3. If you connect EVSEs in a daisy chain, put the RJ45 plug of Ethernet cable to the next EVSE (D) in the secondary Ethernet RJ45 socket (E).

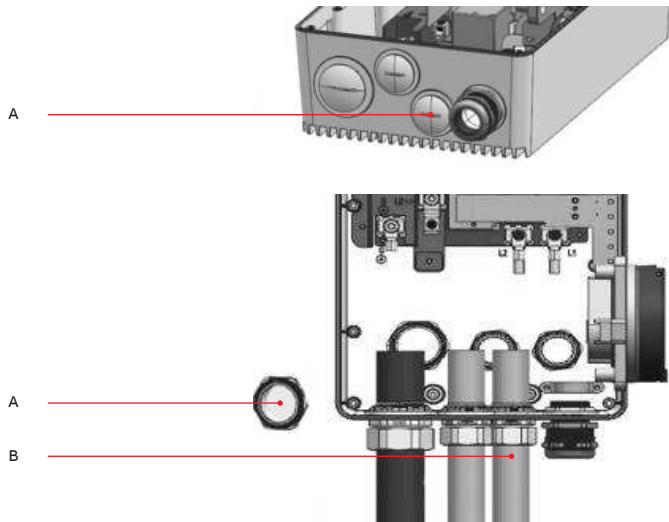

### Insert the smart meter communication conduit

1. Remove the conduit enclosure plug (A) from the EVSE.
2. Put the smart meter communication conduit (B) through the inlet hole.
3. Install the smart meter communication conduit.

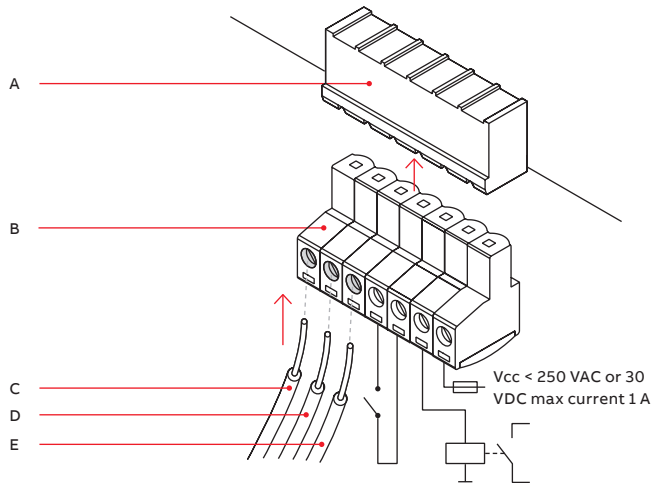

### Insert and connect the wires for the smart meter communication

Connect the smart meter with ModBus RTU (RS485) to the EVSE.

#### Procedure

1. Remove the terminal block connector (B) from the connector (A) of the smart meter connection.
2. Connect the wires:
  - a. Connect the positive wire (C).
  - b. Connect the negative wire (D).
  - c. If the smart meter has a common isolated ground for shielded wire, connect the wire (E).
3. Tighten the screws to the correct torque. For the specification, refer to chapter [Technical data](#), page 32.
4. Install the terminal block connector (B) on the connector (A).

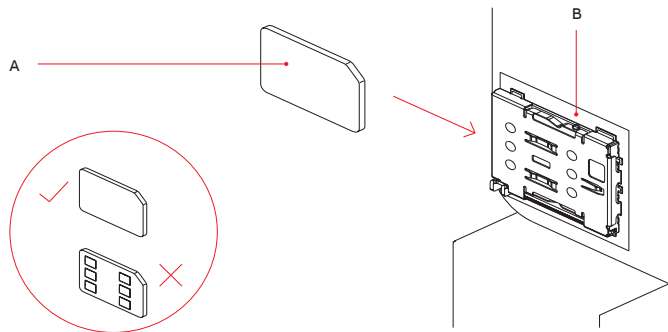

### Insert the Nano-M2M SIM card

#### Procedure

1. Insert the Nano-M2M SIM card (A) into the socket (B). Make sure that the position of the connection points is correct. Refer to section [Internal components](#), page 15.

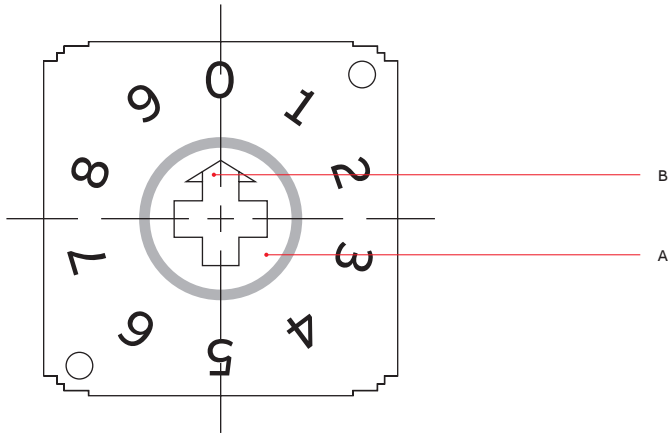

### Rotary switch set current limit

#### Procedure

1. Use the screwdriver to rotate the dip switch (A) to make the arrow (B) point to different number for different current limit.

Position of switch	Current limit
0	80 A
1	64 A
2	56 A
3	48 A
4	40 A
5	32 A
6	24 A
7	16 A
8	10 A
9	Not used, switch limit will be invalid

# Commissioning

## General commissioning procedure

Table 29: Preliminary requirements



Mobile device with the TerraConfig app



Label with PIN. Refer to section [In the box, page 16](#)

### TerraConfig app to do the commissioning

The TerraConfig app is available on the [Apple Store](#) and on the [Google Play Store](#). The app is necessary to do the commissioning.

### Procedure

1. Download the TerraConfig app.
  - For an Android OS mobile device, go to [Google Play Store](#)
  - For an iOS mobile device, go to [Apple Store](#)
2. Energize the EVSE. Close the breaker that supplies the power to the EVSE.
3. Set up the EVSE.



### Warning:

Hazardous voltage

- Be careful when you work with electricity
- The power supply comes on
- A series of self-checks start, to make sure that the EVSE works correctly and safely
- If the EVSE detects a problem, the error LED comes on

4. Open the TerraConfig app.
5. Enter the PIN.
6. Do these steps, on the TerraConfig app:
  - a. Update the product firmware. Do this step again until the TerraConfig app does not detect newer firmware.
  - b. Adjust the parameter settings for your EVSE configuration.

# Troubleshooting

## Troubleshooting procedure

1. Try to find a solution for the problem with the aid of the information in this document.

2. If you cannot find a solution for the problem, contact your local representative of the manufacturer. Refer to section [Manufacturer and contact data](#) at the end of this document.

**Table 31: Troubleshooting table**

Problem (error code)	Possible cause	Possible solution
Residual current detected (0x0002)	There is residual current (20 mA AC) in the charge circuit. Current leaks into the ground	De-energize the EVSE
		Contact your local representative of the manufacturer or a qualified electrical contractor
		Do a check of the protective earth line of the connector of the AC input
PE missing or swap neutral and phase (0x0004)	The EVSE is not earthed correctly	Install the protective earth conductor
		Examine the electrical connections
		Make sure that the connection of the phase and line and neutral wires is correct
Over voltage (0x0008)	The neutral and phase wires are swapped	If necessary, adjust the electrical connections. Refer to chapter <a href="#">Electrical installation</a> , page 21
Under voltage (0x0010)	The maximum voltage on the power input is too high	Make sure that the voltage from the grid is not more than specified
Over current (0x0020)	The voltage on the power input is not sufficient	Make sure that the voltage from the grid is not less than specified
		Examine the EV charge cable connection
Severe over current (0x0040)	There is an overload on the EV side	Connect the EV charge cable correctly
		Examine the EV charge cable connection
Over temperature (0x0080)	There is an overload on the EV side	Connect the EV charge cable correctly
		Do a check of the operation temperature on the product label. If the ambient temperature is too high, the EVSE will decrease the output current automatically
		If it is necessary, install the EVSE in an environment with a lower ambient temperature
		Make sure that the voltage from the grid is not more than specified
		If you can not solve the problem, do not use the EVSE Contact your local company representative or a qualified electrical contractor

**Table 31: Troubleshooting table (continued)**

Problem (error code)	Possible cause	Possible solution
Power relay fault (0x0400)	The relay contact is detected in wrong state or has damage	Examine the relay contact
		If necessary, adjust the current
		If necessary, replace the relay contact
Internal communication failure (0x0800)	The printed circuit boards of the EVSE fail to communicate with each other	Connect the EVSE to the internet
		Do a check of the WiFi signal at the site
		Do a check of the Nano-SIM card connection and the 4G signal strength at the site
E-Lock failure (0x1000)	Error to lock / unlock the charge connector	Examine the connection of the EV charge cable
		If necessary, connect the EV charge cable
Missing phase (0x2000)	B or C phase are missing or one of these phases is missing	Examine the electrical connections
		Make sure that the connection of the phase and line and neutral wires is correct
		If necessary, adjust the electrical connections. Refer to chapter <a href="#">Electrical installation</a> , page 21
Modbus communication lost (0x4000)	The Modbus communication is lost	Do a check on the connection of the wires and the polarity
		Do a check if all addresses are unique
		Do a check if the baud rate is the same as the other device or meter
		Do a check if the parity value of the other device or meter agrees with the EVSE 'None'
		Do a check if the stop bit and data bit are the same on the other device or meter
Offline charging record reaches memory limit (0x8000)	Lost internet connection or incorrect configuration	Re-connect or re-establish internet connection When EVSE is used offline, select offline in ChargerLink menu, TerraConfig app
The display shows that the EV is not ready for the charge session or the ChargerSync app shows 'waiting for EV'	The EV is unavailable	Wake up the EV. Refer to the user manual
		Make sure that the power supply to the EVSE is on
The EV is not charged	There is a problem with the EVSE	Examine the EVSE to find if is working correctly
		Examine the ChargerSync app and the charge LED to make sure that the charging session is authorized
	The EV charge cable is defective	Start the charging session
		Examine the EV charge cable
		If the standard supplied EV charge cable is defective, replace the EV charge cable

**Table 31: Troubleshooting table (continued)**

Problem (error code)	Possible cause	Possible solution
The EV connection or authorization process fails	The EV charge cable is defective	Examine the EV charge cable
		If the standard supplied EV charge cable is defective, replace the EV charge cable
		Examine the connection of the EV charge cable
	There is a problem with the ChargerSync app or the RFID card	If necessary, connect the EV charge cable
		Make sure that the user has registered in the ChargerSync app
		Make sure that you use a RFID card that the manufacturer provided
The EV connection or authorization process fails	There is a problem with the ChargerSync app or the RFID card	Make sure that the RFID card is added on the ChargerSync app
		Start the ChargerSync app
		Start the authorization process

**De-energize the EVSE**

1. Open the breaker that supplies the power to the EVSE.
2. Wait for minimum 1 minute.



## Technical data

<b>AC input</b>	
Charging type	Mode 3 charging, level 2
Input/output power rating and current	9.6 kW / 40 A, 19.2 kW / 80 A
Input/output voltage, frequency	208 / 240 Vac, 50 / 60 Hz
Network type	TT, TN
Cable type / Cable storage	SAE J1772, type 1 cable, 25 ft (7.6 m). Cable is wrapped around charger and front holster inlet
Protections	Overcurrent, overvoltage, undervoltage, integrated surge protection
Ground fault circuit interrupter	Integrated 20 mA AC CCID, no additional required
Overvoltage category	III
Energy metering	Revenue grade energy meter Class B ( $\pm 2\%$ )
Rotary switch set current limit options 80 A model	10 A / 16 A / 24 A / 32 A / 40 A / 48 A / 56 A / 64 A / 80 A
Rotary switch set current limit options 40 A model	10 A / 16 A / 24 A / 32 A / 40 A
Stand-by mode power consumption	3 W / 5.6 W with display
Power-down backup capacitor	Able to store charge transaction during power down
Noise level	Less than 40 dB (A)

<b>Connectivity</b>	
Communication protocols	OCPP 1.6J, Modbus RTU RS485 (primary and secondary), Modbus TCP/IP (secondary)
Mobile communication	Nano-SIM socket type M2M (Machine To Machine): 4G (LTE), WCDMA
Ethernet	1x 1/100 BaseT, RJ45 Socket
Extra ethernet (daisy chain)	1x 1/100 BaseT, RJ45 Socket
Ethernet Cable type	Category 5 (Cat 5)
WiFi (WAN)	IEEE 802.11 b/g/n, 2.4 GHz
External meter communication	Primary mode: Modbus RTU (RS485)
Local controller communication	Secondary mode: Modbus RTU (RS485), Modbus TCP/IP
Modbus RTU (RS485) cable type	Twisted pair, shielded cable (recommended)
ModBus RTU baud rate	9600 bps standard, with TerraConfig app configurable to 4800, 9600, 19200, 38400, 57600 and 115200 bps
ModBus RTU bus primary/secondary	EVSE is Modulus primary/secondary configurable via TerraConfig app
Bluetooth	BLE 5.0
Compatible mobile device operating systems	Android 4.4 or higher / iOS8 or higher
RFID	ISO/IEC 14443A, MIFARE™ Classic, 1K and 4K memory
Available configurable contacts	1 input, 1 output
Configurable output contact rated load	250 VAC or 30 VDC, max current 1 A
<b>User interface</b>	
User authentication	ABB RFID card (1 included) or ChargerSync™ app or portal
User interface / Installer interface	ChargerSync™ app or portal / TerraConfig app and portal for setup
Status indication	5 LEDs
Display	Wakeup functionality via touch
<b>Configuration</b>	
Software update	OCPP 1.6J, ChargerSync™ app or portal, Terraconfig app
Control and configuration	OCPP 1.6J, ChargerSync™ app or portal, Terraconfig app and portal
<b>Ambient</b>	
NEMA enclosure type	Type 4
IP	IP65
IK rating according to IEC 62262 (enclosure and display)	IK10 (IK8+ for an operation temperature between -35 and -30 °C)
Operation altitude	13123 ft. (4000 m) (maximum)
Operating temperature range	-30...+55 °C (derating may apply)
Storage temperature range	-40...+85 °C
Storage conditions	Indoor, dry
Relative humidity	<95%, non-condensing

<b>Mechanical</b>		
Mounting		Wall or floor using a pedestal
Dimensions	H × W × D	15.75 × 9.06 × 4.92 in (400 × 230 × 125 mm)
Weight 40/80 A		23,80 lb / 26,01 lb (10.8 kg / 11.8 kg)
<b>Torque specifications</b>		
Cabinet cover screws		0.9 Nm / 7,96 lb-in
Inner cabinet/ maintenance cover screws		0.9 Nm / 7,96 lb-in
Display board screws		0.6 Nm / 5,31 lb-in
AC input screws		2.5 Nm / 22,12 lb-in
AC input mechanical lug		2.0 Nm / 17,70 lb-in
EV charge cable screws		2.5 Nm / 22,12 lb-in
Holster inlet screw		0.7 Nm / 6,19 lb-in
Terminal block, external meter, input and output		0.5 Nm / 4,42 lb-in
Mounting screws		4.4 Nm / 38,94 lb-in
<b>Wire specifications</b>		
AC input mechanical lug		Strip length 0.55 in (14 mm), supported range 8 - 2 AWG (8.36 - 35 mm <sup>2</sup> )
AC input cold pressed ring terminal 80A		Strip length 0.55 in (14 mm), 2 AWG (35 mm <sup>2</sup> )
AC input cold pressed ring terminal 40A		Strip length 0.55 in (14 mm), 6 AWG (13 mm <sup>2</sup> )
PE cold pressed ring terminal		Strip length 0.33 in (8.5 mm), 8 AWG (8,36 mm <sup>2</sup> )
Terminal block, external meter, input and output		Strip length 0.19 in (5 mm), supported AWG range 24 - 12 (0.20 - 3,3 mm <sup>2</sup> )
<b>Certification and standards</b>		
Safety standards		UL 2594, UL 2231-1, UL 2231-2, UL 1998, CSA C22.2. NO.280, NMX-J-667-ANCE
Codes and standards		FCC Part 15 Class B, ENERGY STAR
Certification		SGS
<b>Warranty</b>		
		24 months
<b>AC input cable</b>		
Cable shielding (optional)		The local rules require shielded cables. The cable shielding must be connected to the PE rail at the two ends of the cable
Diameter of the phase conductors		Refer to the local rules
Diameter of the PE conductor		The same as the diameter of the phase conductors

- Consult your local electrical codes for the correct wire size, based on the environment, the conductor type and the rating of the EVSE
- The wire AWG is based on the copper wire type

## Circuit breaker rating

Max output (charging) current (A)	Typical circuit breaker (A)	Typical line wire specifications (AWG)	Supported by included mechanical lug	Supported by included cold pressed ring terminal	Typical PE wire specifications (AWG)	Supported by included cold pressed ring terminal
10	13	12			12	
16	20	10			12	
24	30	8	8-2		10	
32	40	8	8-2		10	
40	50	6	8-2	6	8	8
48	60	6	8-2		8	8
56	70	4	8-2		8	8
64	80	4	8-2		8	8
80	100	2	8-2	2	8	8



**Note:** Consult with a licensed contractor, licensed electrician, or trained installation expert to ensure compliance with local building and safety standards.

Requirements	Specifications
Dedicated upstream protection device(s)	Breaker
EVSE internal Ground Fault Protection	20 mA AC
Upstream overcurrent protection breaker	Breaker rating see table above Tripping characteristics: type C



**Note:** The breaker value depends on the diameter and the length of the cable, the EVSE rating, and the environmental parameters (for the electrician to decide).

The breaker serves as the main disconnect switch to the EVSE.

<b>Terra AC 40/80 A models</b>					
<b>Rated power (kW)</b>	<b>Max. current (A)</b>	<b>Connector type</b>	<b>Other features</b>	<b>Type</b>	<b>Order code</b>
9.6	40	Cable 25 ft (7.6 m), type 1	RFID, daisy-chain ethernet	Terra AC W9-P8-R-D-0	ABB6AGC105905
		Cable 25 ft (7.6 m), type 1	RFID, 4G, daisy-chain ethernet	Terra AC W9-P8-R-CD-0	ABB6AGC105902
		Cable 25 ft (7.6 m), type 1	RFID, 4G, daisy-chain ethernet, display	Terra AC W9-P8-RD-MCD-0	ABB6AGC082553
19.2	80	Cable 25 ft (7.6 m), type 1	RFID, daisy-chain ethernet	Terra AC W19-P8-R-D-0	ABB6AGC105904
		Cable 25 ft (7.6 m), type 1	RFID, 4G, daisy-chain ethernet	Terra AC W19-P8-R-CD-0	ABB6AGC105903
		Cable 25 ft (7.6 m), type 1	RFID, 4G, daisy-chain ethernet, display	Terra AC W19-P8-RD-MCD-0	ABB6AGC081291
<b>Spare parts</b>					
Charger assembly kit 9.6/19.2 kW UL 40/80 A				SER-Assembly kit 9.6/19.2 kW UL 40/80 A	ABB6AGC107748
Aluminum conduit closure plugs, including 1 * 1 inch and 2 * 3/4 inch				SER-Grommet	ABB6AGC109685
Front cover (non-display, no ABB logo, UL 40/80 A), 2 screws included				SER-Front cover(non-display models, no ABB logo, UL 40/80 A)	ABB6AGC109709
Front cover (display, no ABB logo, UL 40/80 A), 2 screws included				SER-Front cover(display models, no ABB logo, UL 40/80 A)	ABB6AGC109714
Front cover (non-display, UL 40/80 A), 2 screws included				SER-Front cover(non-display, UL 40/80 A)	ABB6AGC109717
Front cover (display models, UL 40/80 A), 2 screws included				SER-Front cover(display models, UL 40/80 A)	ABB6AGC109720
Maintenance cover, internal (non-display, UL 40/80 A), 11 screws included				SER-Maintenance cover (non-display, UL 40/80 A)	ABB6AGC109724
Maintenance cover, internal (display, UL 40/80 A), 11 screws included				SER-Maintenance cover(display, UL 40/80 A)	ABB6AGC109725
Gasket for SAE J1772, type 1 charge connector				SER-TAC-Gasket for SAE J1772, T1	ABB6AGC109902
Holster inlet cover				SER-TAC Holster inlet cover	ABB6AGC109726
SAE J1772, type 1, single phase, 7.6 m, 40 A				SER-TAC-cable T1 7.6m1P40A	ABB6AGC109258
SAE J1772, type 1, single phase, 7.6 m, 80 A				SER-TAC-cable T1 7.6m1P80A	ABB6AGC109256



—

**Manufacturer**

ABB E-mobility  
Heertjeslaan 6  
2629 JG Delft  
The Netherlands

—

**Contact data**

The local representative of the manufacturer can give you support on the EVSE. You can find the contact data here: <https://emobility.abb.com>