

AUTEL®

MAXI**CHARGER** AC**ULTRA**

19.2kW*2



MAXI**CHARGER** ACULTRA

The Fastest AC Charger for Two Vehicles

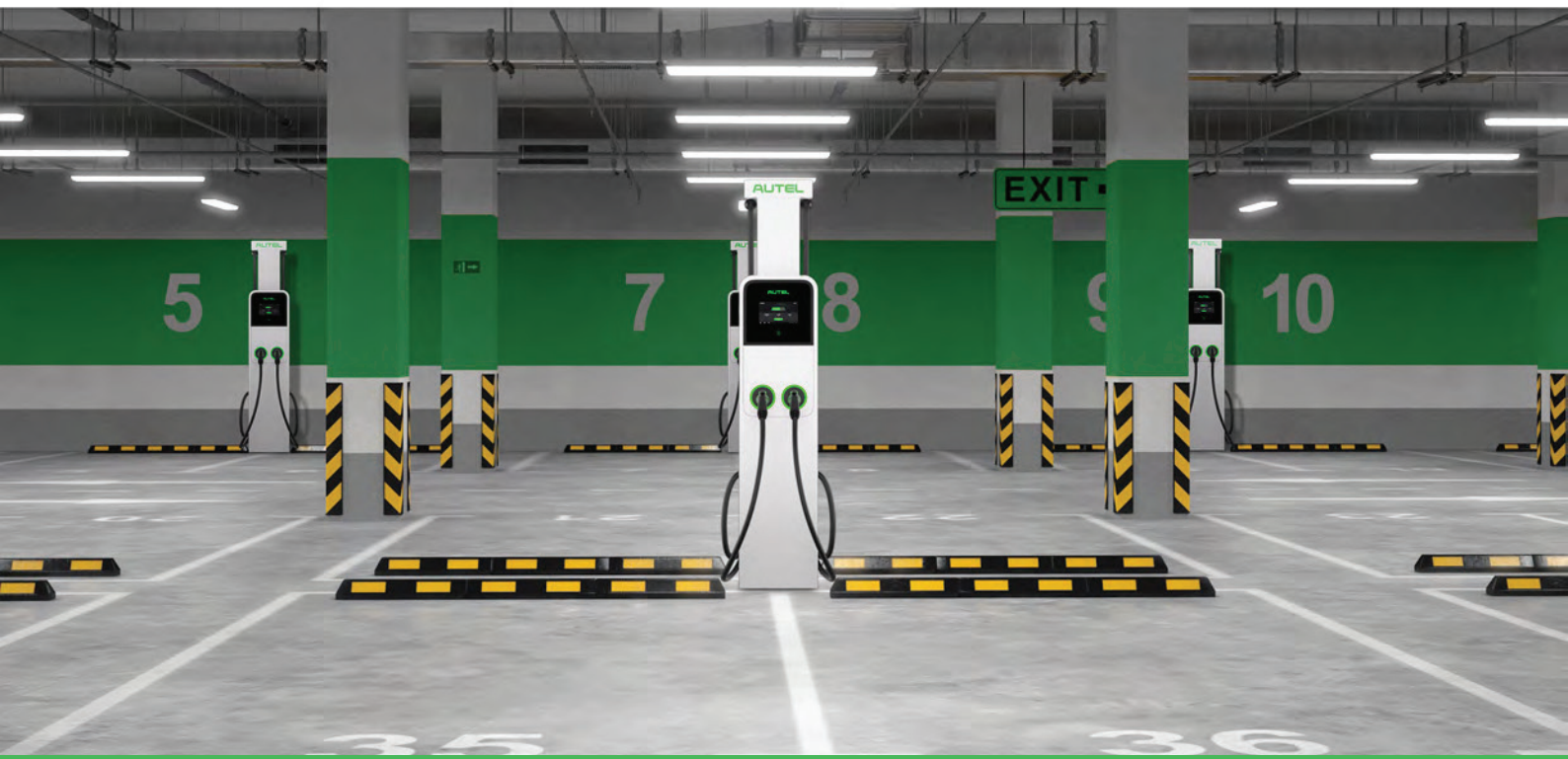

FAST AND EFFICIENT

CREATE AN EXCEPTIONAL CHARGING EXPERIENCE

- At 19.2kW per port this charger leads the industry by fast charging 2 vehicles simultaneously, and generates 75 miles of range within 60 min
- Designed with ISO 15118 Plug & Charge, for a hassle-free charging experience



BEST-VALUE DESIGN

TAILORED FOR COMMERCIAL DEPLOYMENT

- Rugged design allows it to be wall-mounted or floor-mounted to support your application needs
- One-piece construction makes it easy to install resulting in lower costs and a faster ROI











SMART CHARGING

FUTURE-PROOF, FLEXIBLE AND IMPROVES YOUR BOTTOM-LINE

- Smart functionality with OCPP 1.6 and 2.0.1 compliant, can adapt its power usage and provide optimal charging today and into the future
- Reduce capital investment in power capacity

THE BIG VALUE BEHIND THE MAXI**CHARGER** ACULTRA

-  Cable Management
-  One-piece Pedestal
Housing Combination
-  WiFi Hotspot Sharing
-  Power Sharing
-  8-inch HD Advertising Screen
-  APP, RFID Card, Credit Card,
Mobile Payment
-  One-Stop Cloud Network
Management
-  OCPP1.6 / 2.0.1
-  Weather Resistant



TECHNICAL SPECIFICATIONS

PRODUCT INFORMATION

Input/output power rating and current	2*19.2kW (240V AC*80A) Output amperage adjustable via mobile app, from 6A to 80A
Input/output voltage	208V±15%; 240V±15%, 60Hz
Input wiring	L1/L2/PE
Input cord	Hardwired
Connector type	SAE J1772, 7.5m (25') or 5m
Ground fault detection	20mA CCID
Protection	Overcurrent, overvoltage, undervoltage, integrated surge protection
Card reader	Optional: ISO 15693, ISO 14443, NFC
Power measurement accuracy	+/- 1.0% from 1% to full scale

GENERAL CHARACTERISTICS

Enclosure rating	NEMA 3R
Operating altitude	2000m
Operating temperature range	- 40°C ~ + 50°C
Storage temperature range	- 40°C ~ + 85°C
Mounting	Wall or floor using a pedestal
Dimensions (H*W*D)	625 × 320 × 170mm

USER INTERFACE

Status indication	LED / APP / LCD (8 inch,1280*720 touch screen)
User interface	Autel Charge APP; Autel Charge Cloud
Connectivity	Bluetooth, Wi-Fi, Ethernet, 4G, RS485
Communication protocols	OCPP 1.6J (Can be upgraded to OCPP 2.0.1 later)
User authentication	APP, RFID card, Credit Cards (Optional)

SOFTWARE UPDATE

OTA updates via web portal

CERTIFICATION AND STANDARDS

Safety and compliance	UL 2231-1, UL 2231-2, UL2594, NEC Article 625, CSA C22.2, UL 916
EMC compliance	FCC 15 Class B
Certification	Energy Star, OpenADR 2.0b
Warranty	36 months, warranty extension possible

AUTEL[®]

Autel Intelligent Technology Corp., Ltd

☎ Phone: (844) 765-0150

✉ E-mail: evsupport@autel.com

🌐 Website: autelenergy.com

Autel Energy





User Manual
MaxiCharger AC Ultra (UL)

Trademarks

Autel® and MaxiCharger® are trademarks of Autel Intelligent Technology Corp., Ltd., registered in China, the United States and other countries. All other marks are trademarks or registered trademarks of their respective holders.

Copyright Information

No part of this manual may be reproduced, stored in a retrieval system or transmitted, in any form or by any means, electronic, mechanical, photocopying, recording, or otherwise without the prior written permission of Autel.

Disclaimer of Warranties and Limitation of Liabilities

All information, specifications and illustrations in this manual are based on the latest information available at the time of printing.

Autel reserves the right to make changes at any time without notice. While information of this manual has been carefully checked for accuracy, no guarantee is given for the completeness and correctness of the contents, including but not limited to the product specifications, functions, and illustrations.

Autel will not be liable for any direct, special, incidental, indirect damages or any economic consequential damages (including the loss of profits).

IMPORTANT

Before operating or maintaining this unit, please read this manual carefully, paying extra attention to the safety warnings and precautions.

For Services and Support (24/7):

Web: www.autelenergy.com

Tel: (844) 765-0150

Email: evsupport@autel.com

Address: 36 Harbor Park Drive, Port Washington, New York, USA 11050

For technical assistance in all other markets, please contact your local selling agent.

CONTENTS

1	USING THIS MANUAL.....	1
1.1	CONVENTIONS	1
1.1.1	<i>Bold Text</i>	1
1.1.2	<i>Notes and Important Messages</i>	1
1.1.3	<i>Hyperlinks</i>	1
1.1.4	<i>Illustrations</i>	1
1.1.5	<i>Revision History</i>	1
2	SAFETY.....	2
2.1	SAFETY MESSAGE	2
2.2	SAFETY INSTRUCTIONS	2
3	GENERAL INTRODUCTION.....	4
3.1	PRODUCT OVERVIEW.....	5
3.1.1	<i>Front View</i>	5
3.1.2	<i>Bottom-Up View</i>	6
3.1.3	<i>Back and Side Views</i>	6
3.1.4	<i>Inside View</i>	6
3.1.5	<i>Overview of Pedestal (Optional)</i>	7
3.1.6	<i>Overview of Cable Management System (CMS) (Optional)</i>	7
3.2	ELECTRICAL DESIGN.....	8
4	INSTALLATION.....	10
4.1	CHARGING STATION (WALL MOUNT)	11
4.1.1	<i>Checking the Box</i>	11
4.1.2	<i>Installation Tools (Not Included)</i>	12
4.1.3	<i>Choosing a Location</i>	12
4.1.4	<i>Installing the Charging Station</i>	13
4.1.5	<i>Completing the Installation</i>	17
4.2	CHARGING STATION + PEDESTAL	18
4.2.1	<i>Checking the Box</i>	18
4.2.2	<i>Installation Tools (Not Included)</i>	19
4.2.3	<i>Preparing a Foundation</i>	20
4.2.4	<i>Installing the Pedestal</i>	21
4.2.5	<i>Installing the Charging Station</i>	23
4.2.6	<i>Completing the Installation</i>	26
4.3	CHARGING STATION + CMS_MODEL B	28
4.3.1	<i>Checking the Box</i>	28
4.3.2	<i>Installation Tools (Not Included)</i>	30
4.3.3	<i>Installing the CMS</i>	31

4.3.4	<i>Installing the Charging Station</i>	33
4.3.5	<i>Completing the Installation</i>	37
4.4	CHARGING STATION + PEDESTAL + CMS.....	38
4.4.1	<i>Checking the Box</i>	38
4.4.2	<i>Installation Tools (Not Included)</i>	40
4.4.3	<i>Preparing a Foundation</i>	41
4.4.4	<i>Installing the Pedestal</i>	42
4.4.5	<i>Installing the Cable Management System (CMS)_Model A (Optional)</i>	44
4.4.6	<i>Installing the Cable Management System (CMS)_Model B (Optional)</i>	46
4.4.7	<i>Installing the Charging Station</i>	48
4.4.8	<i>Completing the Installation</i>	51
4.5	AC INPUT WIRING	53
4.5.1	<i>Cable Specifications</i>	53
4.5.2	<i>Installing Conduit</i>	53
4.5.3	<i>Connecting the Wires</i>	54
4.5.4	<i>Adjusting the Rated Current</i>	55
4.6	CONNECTING TO THE INTERNET	56
4.6.1	<i>Via the Ethernet cable</i>	56
4.6.2	<i>Via Cellular Network</i>	57
4.7	ENERGIZING THE MAXICHARGER.....	57
5	LOCAL SERVICE PORTAL OPERATIONS.....	58
5.1	SETTING THE OCPP PARAMETERS.....	58
5.2	CONFIGURING THE CLOUD PLATFORM	62
6	MAINTENANCE.....	63
6.1	INSPECTION AND MAINTENANCE.....	63
6.1.1	<i>Routine Maintenance</i>	63
6.1.2	<i>Special Inspections</i>	64
6.2	REMOTE MAINTENANCE	64
6.3	MAINTENANCE SCHEDULE	64
7	TROUBLESHOOTING.....	65
8	SPECIFICATIONS	66
8.1	GENERAL SPECIFICATIONS.....	66
8.2	PRODUCT DIMENSIONS.....	69
9	COMPLIANCE	71
10	APPENDIX.....	73
10.1	FAULT CODE LIST.....	73

1 Using This Manual

This manual provides the installation and operation procedures of the MaxiCharger AC Ultra. Read through this manual and familiarize yourself with the instructions of the MaxiCharger prior to installation to ensure a successful installation and operation process.

1.1. Conventions

The following conventions are used:

1.1.1 Bold Text

Bold text is used to highlight selectable items such as buttons and menu options.

1.1.2 Notes and Important Messages

Notes

A **NOTE** provides helpful information such as additional explanations, tips, and comments.

Important

IMPORTANT indicates a situation which, if not avoided, may result in damage to the test equipment or vehicle.

1.1.3 Hyperlinks

Hyperlinks or links that take you to other related articles, procedures, and illustrations are available in electronic documents.

1.1.4 Illustrations

Illustrations used in this manual are samples, and the actual product (s) or screens may vary.

1.1.5 Revision History

Version	Date	Descriptions
V1	2022.12.15	Initial version
V2	2023.05.12	Merged dual-port and single-port MaxiCharger version

2 Safety

For your own safety and the safety of others, and to prevent damage to the device and vehicles upon which it is used, it is important that the safety instructions presented throughout this manual be read and understood by all persons operating or coming into contact with the device.

2.1. Safety Message

Safety messages are provided to help prevent personal injury and equipment damage. All safety messages are introduced by a single word indicating the hazard level.

DANGER

Indicates an imminently hazardous situation with a high risk level which, if the danger is not avoided, will cause death or serious injury.

WARNING

Indicates a potentially hazardous situation with moderate risk level which, if the warning is not obeyed, can cause death or serious injury.

CAUTION

Indicates a potentially hazardous situation with a medium risk level which, if the caution is not obeyed, may cause minor or moderate injury or damage to the equipment.

2.2. Safety Instructions

The safety messages herein cover situations Autel is aware of. Autel cannot know, evaluate or advise you as to all of the possible hazards. You must be certain that any condition or service procedure encountered does not jeopardize your personal safety.

SAFETY WARNINGS

- Read and follow all warnings and instructions before installing and operating the charger.
- This equipment should only be installed by a licensed electrician in accordance with all local codes and ordinances.
- This equipment must be grounded through a permanent wiring system or an equipment-grounding conductor.
- Do not install or use this equipment near flammable, explosive, harsh, or combustible materials, chemicals or vapors.
- Children should be supervised when around this equipment.
- Do not insert fingers or foreign objects into the electric vehicle connector.
- Do not use the equipment if the flexible power cord or EV cable is frayed, broken or otherwise damaged, or fails to operate.
- Do not use the equipment if the enclosure or the EV connector is frayed, broken or otherwise damaged, or fails to operate.

- Use 194 °F (90 °C) wire copper conductors only.
- Do not operate the equipment outside its operating temperature range of -40 to 131 °F (-40 to 55 °C).
- Incorrect installation and testing of the equipment could potentially damage the vehicle's battery, components, and/or the equipment itself.
- Handle the equipment with care during transportation. Do not subject it to strong force or impact or pull, twist, tangle, drag or step on the equipment, to prevent damage to it or any components.
- If the rules described in the manual contradict your local ordinances, the local ordinances shall prevail.

3 General Introduction

The MaxiCharger AC Ultra has dual ports and single port available. Featured as "easy installation, convenient maintenance", the charger is designed as a commercial charger to charge electric vehicles (hereinafter referred to as EVs). The charger provides a safe, reliable, fast, and smart charging solution.

This manual will instruct you on how to install and use this charger.

Intended Use

The MaxiCharger AC Ultra is intended for the AC charging of EVs. It is intended for both indoor and outdoor use.

DANGER

1. Do not operate the equipment in any other ways than described in this manual or other related documents. Not following the instructions may cause potential personal injury and/or damage to the property.
2. Use the equipment only as intended.

NOTE

- This manual applies for both dual-port and single-port MaxiCharger AC Ultra.
 - Unless otherwise specified, only dual-port MaxiCharger will be used in this manual for reference.
-

3.1 Product Overview

3.1.1 Front View

1. Ambient Light Sensor — detects ambient light to adjust screen brightness
2. 8" Capacitive LCD Touchscreen
3. RFID Card Reader
4. POS Payment Device (Optional)
5. Status LED
6. Connector
7. Holster
8. EV Charging Cable

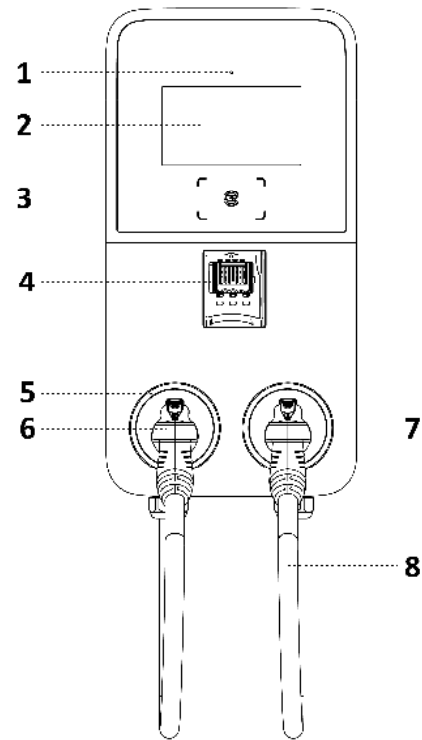

LED Description

LED	Description
Status LED	<ul style="list-style-type: none">● Solid Green: The MaxiCharger is in standby mode.● Breathing Green: An EV is being charged.● Flashing Green: A charging session has ended.● Solid Red: An error has occurred.● Solid Yellow: The MaxiCharger is unavailable due to any of the cases below:<ul style="list-style-type: none">a) Software update;b) A reservation is in progress;c) The MaxiCharger is temporarily disabled by the server.
RFID LED	<ul style="list-style-type: none">● Solid Green: The RFID card reader is available.● Not Illuminated: The RFID card reader is disabled.

3.1.2 Bottom-Up View

- 9. Conduit Knockout — remove before connecting AC input cable (s)
- 10. Ethernet Cable Port

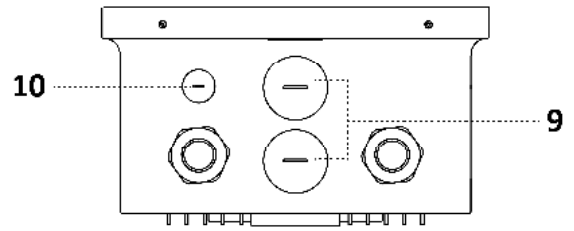

3.1.3 Back and Side Views

- 11. Protruding Screw
- 12. Mounting Hole
- 13. Product Label

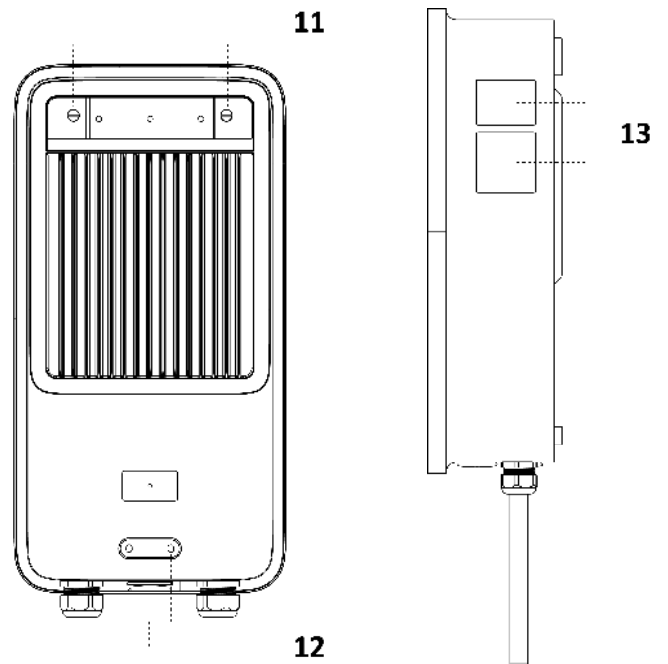

3.1.4 Inside View

- 14. RJ45 Port
- 15. SIM Card Tray

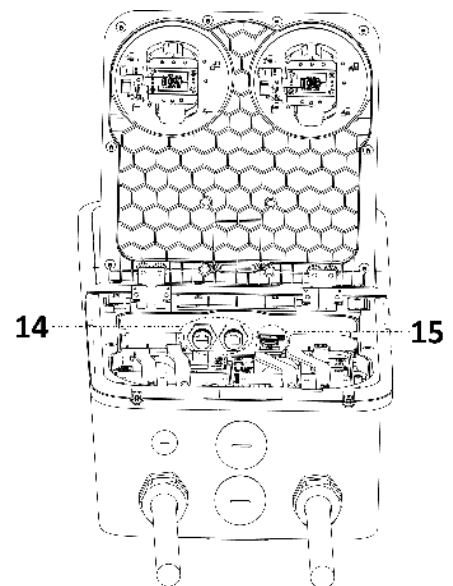

3.1.5 Overview of Pedestal (Optional)

1. Upper Front Cover
2. Lower Front Cover
3. Rubber Ring
4. Strain Relief
5. Mounting Location for Residual Current Breaker
6. PE Busbar (for Pedestal)

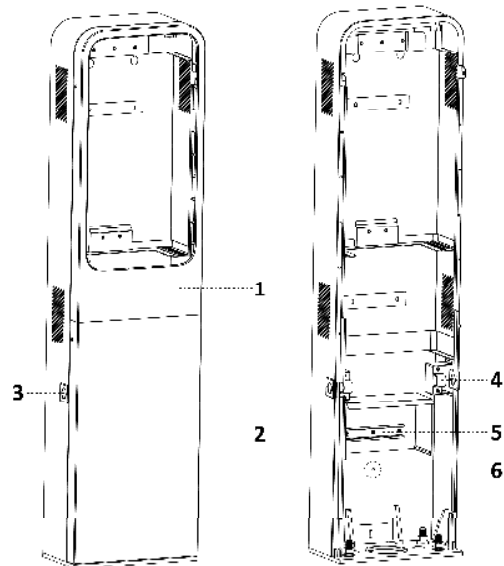

3.1.6 Overview of Cable Management System (CMS) (Optional)

There are two models of cable management system available, called **Model A** and **Model B** in this manual. Each model has two different heights: **107" (2.72 m)** and **78" (1.97 m)**. Follow the installation procedures according to the CMS model.

1. Shipping Screw
2. Cable Clamp
3. Slot

1. Shipping Screw
2. Cable Clamp
3. Slot
4. Locating Pin Hole

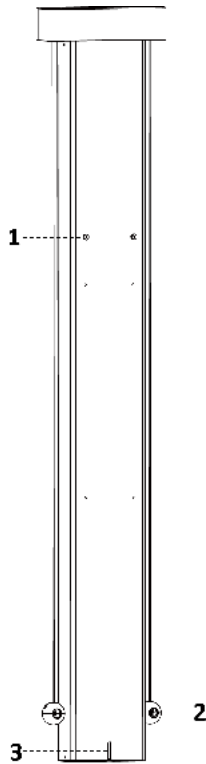

Model A

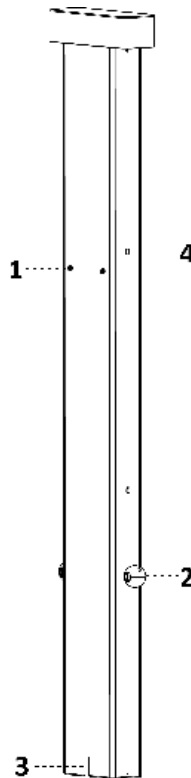

Model B

3.2 Electrical Design

Charging stations are considered continuous load devices (EVs draw maximum load for long durations); therefore, electrical branch circuits must be sized at 125% of the load for North American installations, in accordance with National Electric Code (NEC) requirements. (For other regions, refer to local code.) This means that for a maximum 80 A load at 208/240 V output to an electric vehicle, 100 A breakers are required.

Dual-port MaxiCharger

The dual-port MaxiCharger provides two options of AC input wiring: Single Input and Dual Inputs. **For single input application, before connecting AC input cable, do remember to install the power sharing kit (included in the package) for both ports to share one circuit.** See the wiring below:

Single Input:

1. Main Breaker
2. PE Bus
3. Breaker
4. Power Sharing Kit

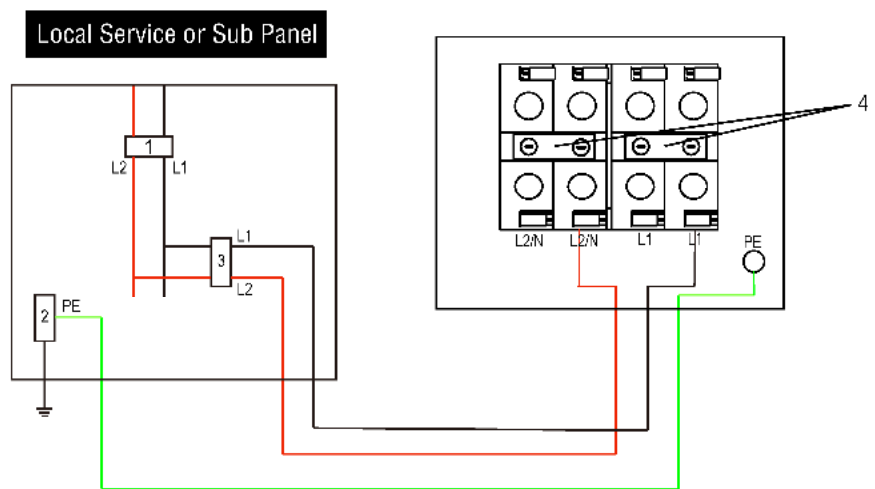

Dual Inputs:

1. Main Breaker
2. PE Bus
3. Breaker

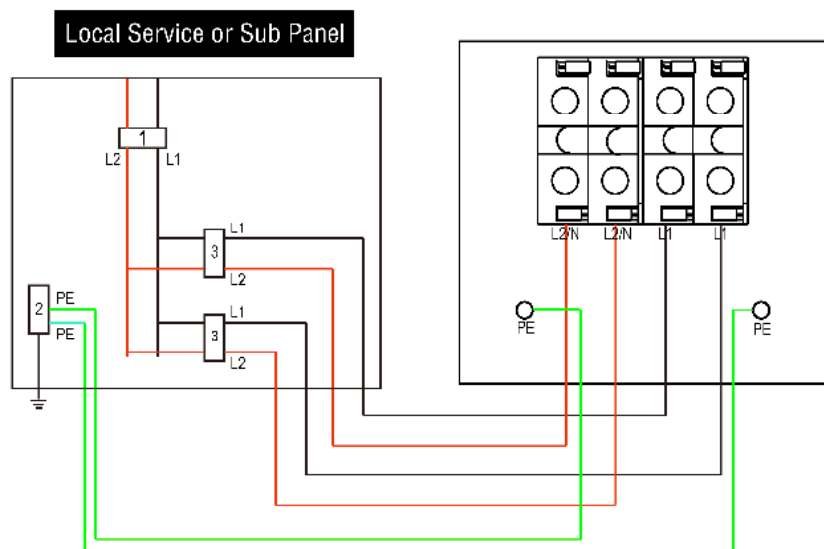

Single-port MaxiCharger

1. Main Breaker
2. PE Bus
3. Breaker

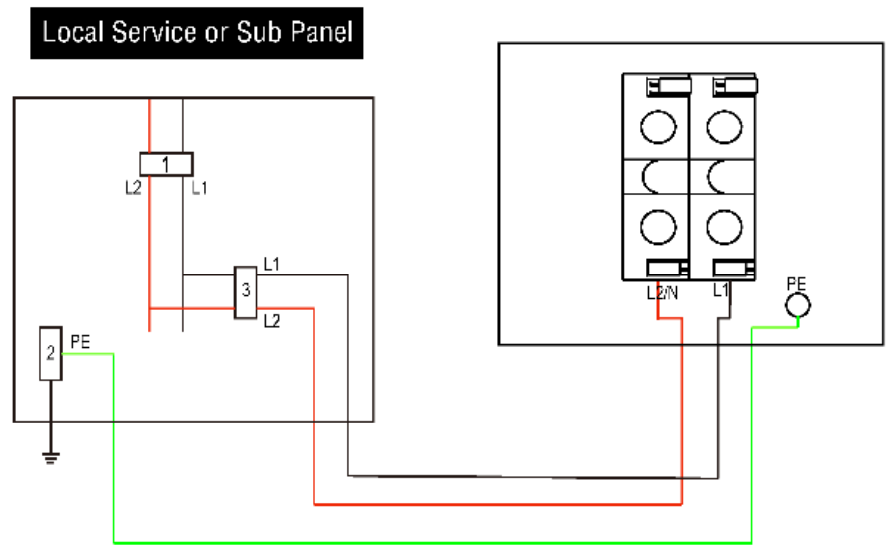

4 Installation







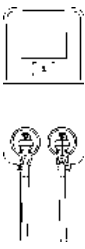

The MaxiCharger AC Ultra has four variations. Please follow the procedures accordingly depending on your order.

No.	Variation	Overview of Installation Steps
A	Charging Station (Wall Mount) See Chapter 4.1 for installation.	<ol style="list-style-type: none">1. Installing the Charging Station2. Connecting Wires3. Completing the Installation
B	Charging Station + Pedestal See Chapter 4.2 for installation.	<ol style="list-style-type: none">1. Installing the Pedestal2. Installing the Charging Station3. Connecting Wires4. Completing the Installation
C	Charging Station + CMS_Model B See Chapter 4.3 for installation.	<ol style="list-style-type: none">1. Installing the CMS_Model B2. Installing the Charging Station3. Connecting Wires4. Completing the Installation
D	Charging Station + Pedestal + CMS See Chapter 4.4 for installation.	<ol style="list-style-type: none">1. Installing the Pedestal2. Installing the CMS3. Installing the Charging Station4. Connecting Wires5. Completing the Installation

4.1 Charging Station (Wall Mount)

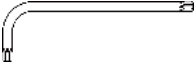
4.1.1 Checking the Box



Ensure the following items can be found in the package.

Charging Station (1 pc)		Wall Dock (1 pc)		Socket Wrench (1 pc)	
M6 x 50 Screw (5 pcs)		*M5 x 10 Screw		Screwdriver T10 (1 pc)	
Wall Anchor (5 pcs)		Drilling Template (1 pc)		Screwdriver T25 (1 pc)	



NOTE

- The quantity of M5 x 10 screw for the dual-port MaxiCharger is 4 pcs, 2 pcs for spare use.
- The quantity of M5 x 10 screw for the single-port MaxiCharger is 2 pcs, 1 pc for spare use.

Power Sharing Kit (For the Dual-port MaxiCharger Only)

Double Tee Nut (2 pcs)		Spacer (4 pcs)		M4 x 26 Screw (4 pcs)	
----------------------------------	---	--------------------------	---	---------------------------------	---

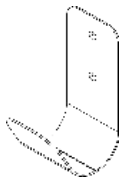
Cable Hanger Kit (Optional)

Cable Hanger (1 pc)		M4 x 60 Screw (2 pcs)		Wall Anchor (2 pcs)	
-------------------------------	---	---------------------------------	---	-------------------------------	---

4.1.2 Installation Tools (Not Included)

Prepare the following installation tools:

- Tape Measure
- Spirit Level
- Marker
- Drill
- Drill Bit, 0.31" (8 mm)
- Phillips Screwdriver
- Wire Stripper
- Crimping Tool
- Flathead Screwdriver
- Cable Lug (Recommended: EVN25-16 for L1&L2/N wire; RNB8-6S for PE wire)

NOTE

- The tools mentioned above are not provided. Be sure to have all the tools ready prior to installation.
 - This tool list does not necessarily include all the tools you may need.
-

4.1.3 Choosing a Location

- Prepare a flat and plumb wall capable of supporting a MaxiCharger.
- Allow the charging cable to remain within its bending tolerance.
- Not prone to potential damages.

IMPORTANT

Always check local codes and ordinances to ensure compliance.

4.1.4 Installing the Charging Station

Step 1

1. Place the drilling template against the wall, minimum 18" (450 mm) above the ground, and level it using a spirit level.
2. Mark five holes. Remove the drilling template.
3. Drill the five holes at the marked locations measuring 0.31" (8 mm) in diameter and 1.97" (50 mm) in depth in the wall.
4. Insert the five wall anchors into the holes.

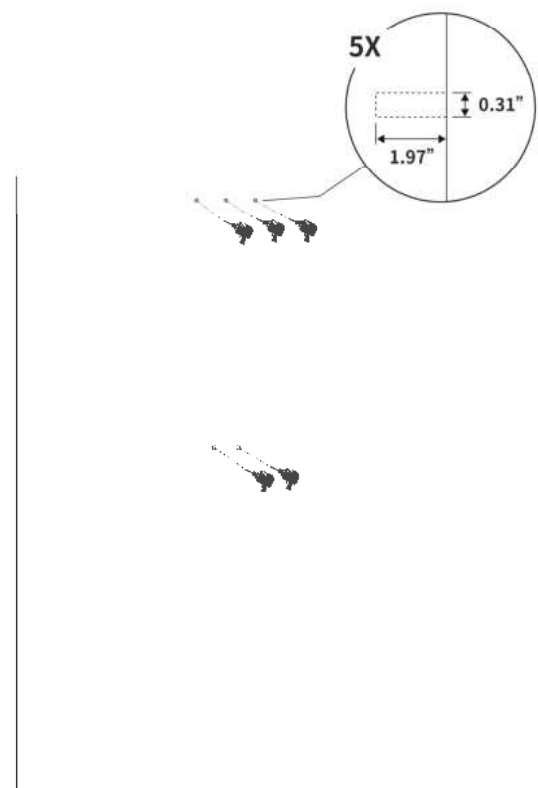
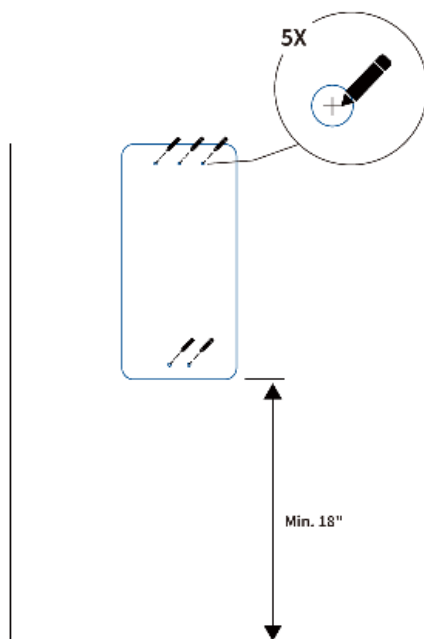

Step 2

1. Attach the wall dock to the mounting location by screwing three M6 x 50 screws into the upper holes. Tighten the three screws to 4–5 ft/lbs (5–7 Nm) using the socket wrench provided.

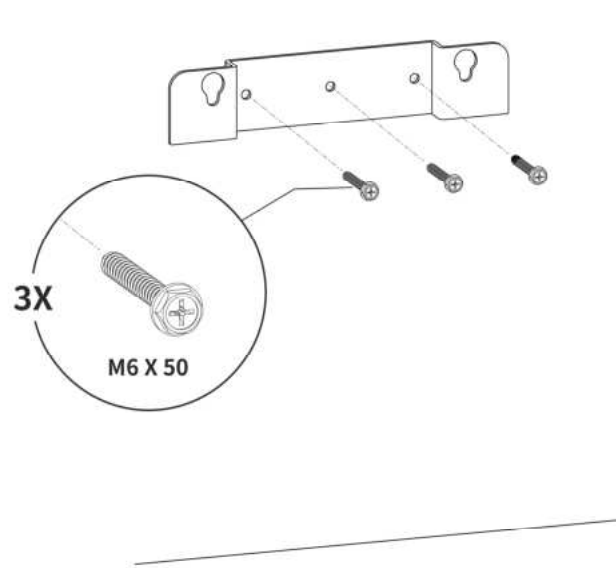

Step 3

1. Attach the charging station to the wall dock by inserting the two protruding screws on the back of the charging station into the upper two mounting holes and slide the charging station downwards.

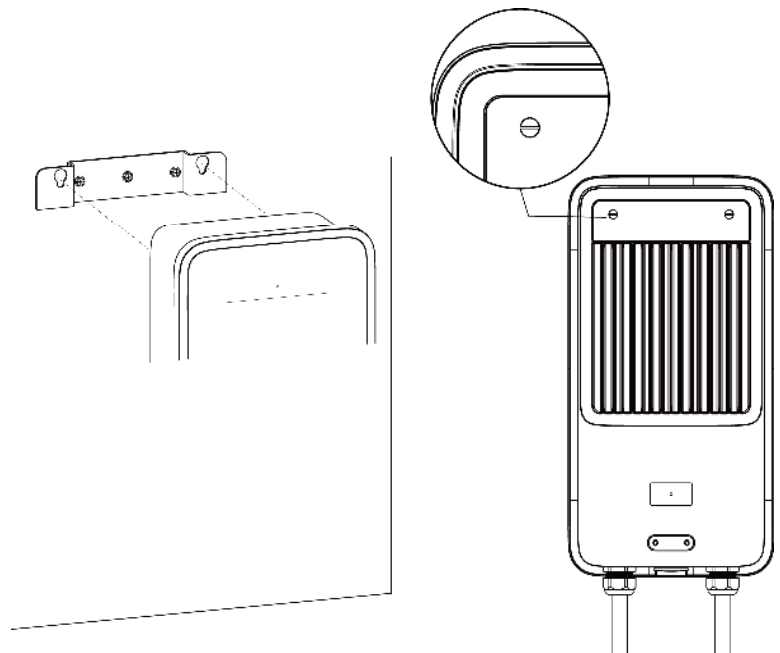

- Loosen the two M3 x 8 screws at the bottom of the charging station using the screwdriver T10 and remove the faceplate. **Set them aside.**

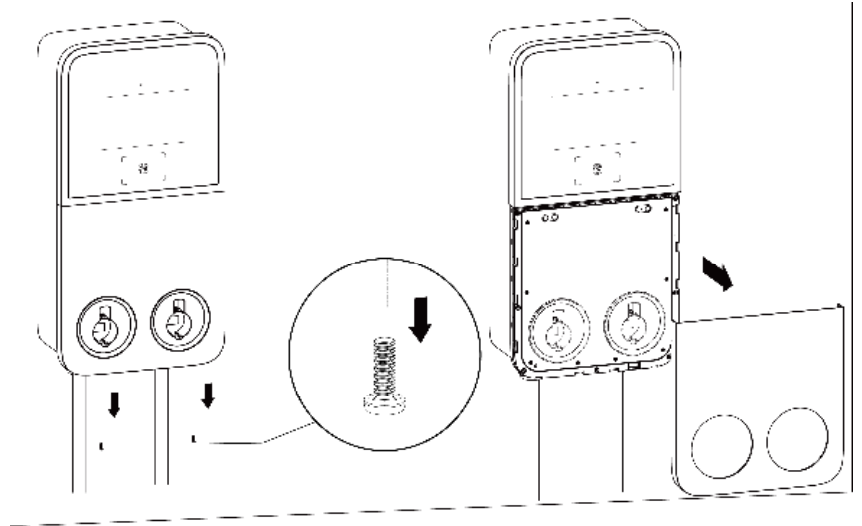

- Unscrew the eight M3 x 8 screws using the screwdriver T10. **Set the screws aside.**

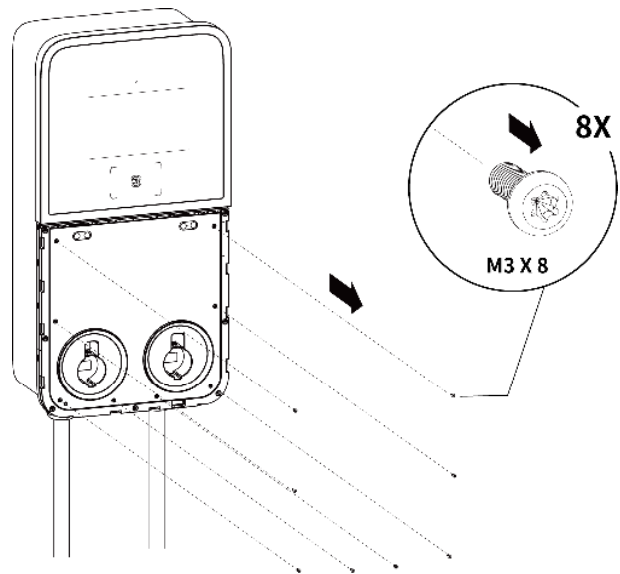

- Flip the maintenance cover upward. Next, insert the two M6 x 50 screws and tighten them to 4–5 ft/lbs (5–7 Nm) using the socket wrench to secure the charging station.

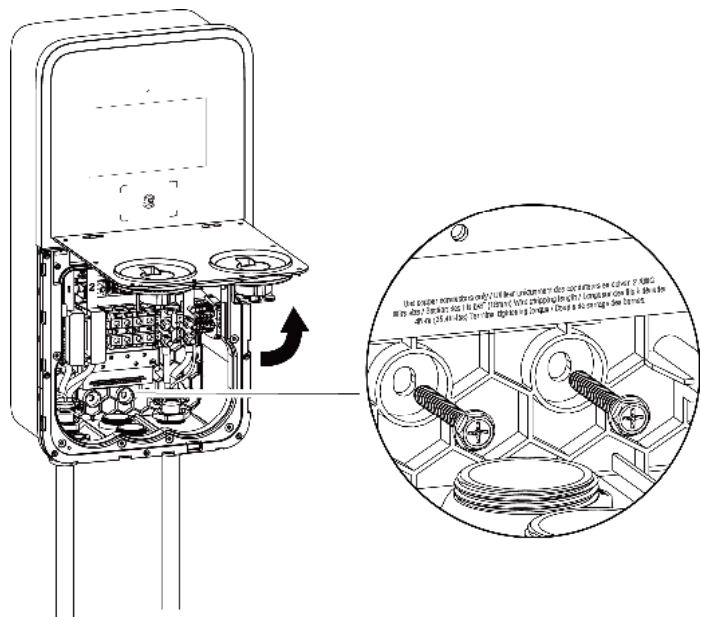

Mounting the Cable Hangers (Optional)

1. Place the cable hangers against the wall, 30"–39" (750–1000 mm) above the ground and 12" (300 mm) from the charging station.
2. Mark four holes on the wall. Remove the cable hangers temporarily.
3. Drill the four holes at the marked location measuring 0.31" (8 mm) in diameter and 2.36" (60 mm) in depth.
4. Tap the four wall anchors into the holes.
5. Attach the two cable hangers to the mounting location by screwing the four M4 x 60 screws into the holes. Tighten the screws using a Phillips screwdriver.

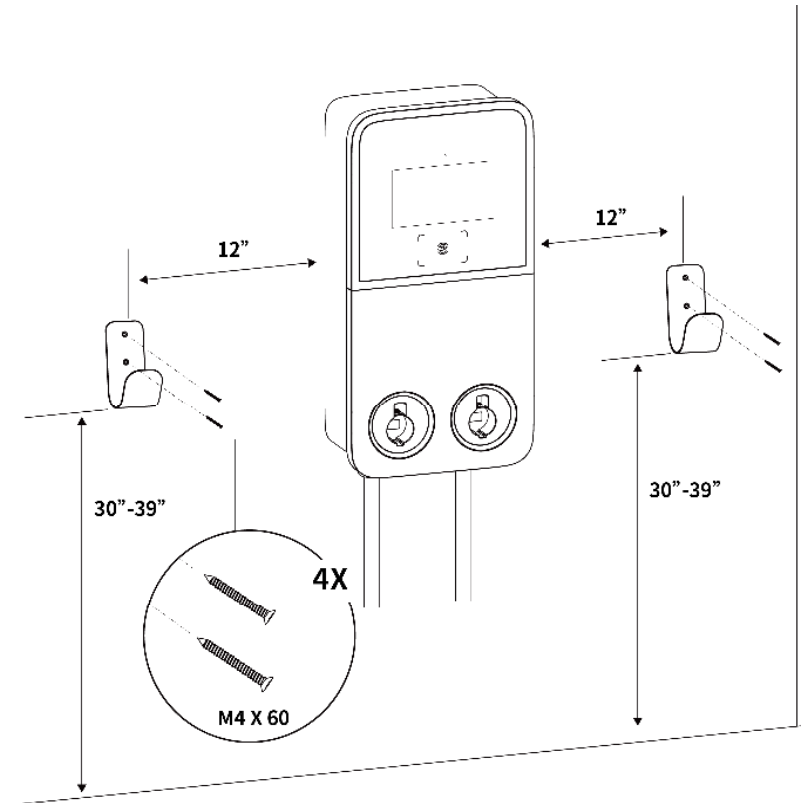

After the above installation steps are finished, you are ready to start AC input wiring. Please refer to **Section 4.5** to proceed.

4.1.5 Completing the Installation

1. Ensure all the installation and wiring are secured and correct. Next, flip the maintenance cover downward. Reinsert the eight M3 x 8 screws and tighten them.

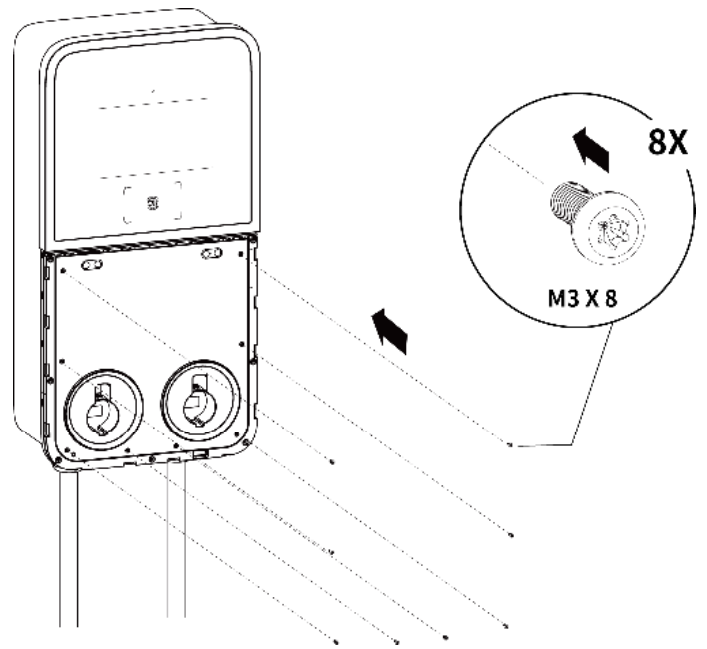

2. Reinstall the faceplate using the two M3 x 8 screws and tighten them accordingly.
3. Plug the charging connectors into the holsters. The installation is completed now.

NOTE



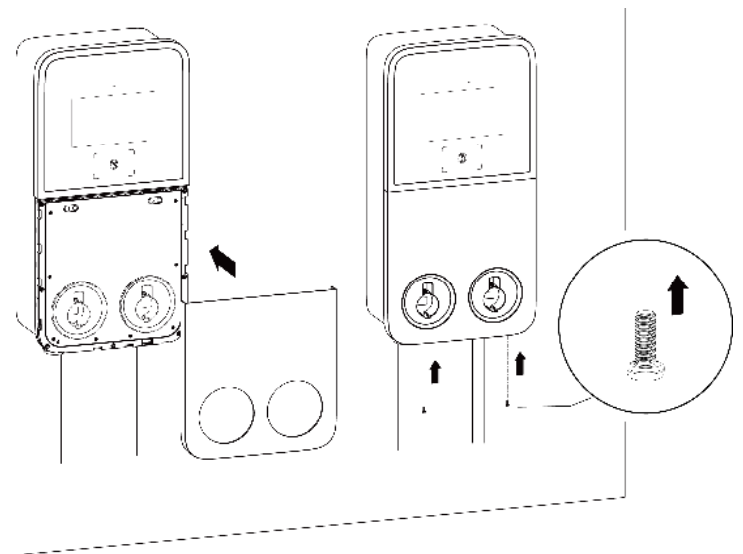

Drape the charging cables on the cable hangers if applicable.



4.2 Charging Station + Pedestal

4.2.1 Checking the Box

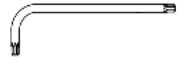

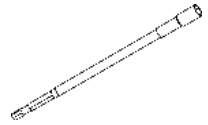
Ensure the following items can be found in the package.

Charging Station (1 pc)		Wall Dock (1 pc)		Screwdriver T10 (1 pc)	
*M5 x 10 Screw		Screwdriver T25 (1 pc)		Socket Wrench (1 pc)	





NOTE

- The quantity of M5 x 10 screw for the dual-port MaxiCharger is 4 pcs, 2 pcs for spare use.
- The quantity of M5 x 10 screw for the single-port MaxiCharger is 2 pcs, 1 pc for spare use.

Power Sharing Kit (For the Dual-port MaxiCharger Only)

Double Tee Nut (2 pcs)		Spacer (4 pcs)		M4 x 26 Screw (4 pcs)	
----------------------------------	---	--------------------------	---	---------------------------------	---

Pedestal Kit

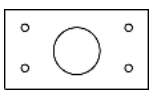
Pedestal (1 pc)		M16 x 150 Expansion Bolt (4 pcs)		M6 x 25 Screw (2 pcs)	
M6 x 16 Screw (7 pcs)		Drilling Template (1 pc)			

4.2.2 Installation Tools (Not Included)

Prepare the following installation tools:

- Scoop Shovel (for digging a hole)
- Marker
- Drill
- Drill Bit, 0.71" (18 mm)
- Open Spanner, 0.94" (24 mm)
- Phillips Screwdriver
- Wire Stripper
- Crimping Tool
- Cable Lug (Recommended: EVN25-16 for L1&L2/N wire; RNB8-6S for PE wire)
- Flathead screwdriver

NOTE

- The tools mentioned above are not provided. Be sure to have all the tools ready prior to installation.
 - This tool list does not necessarily include all the tools you may need.
-

4.2.3 Preparing a Foundation

1. Dig a hole according to the foundation dimensions. The recommended dimensions of the hole are 12" x 18" x 10" (300 x 460 x 250 mm) (H x W x D).

IMPORTANT

- A flat and structurally sound concrete foundation is required for installation.
 - The foundation is recommended to be flush with the ground.
-

2. Trench and excavate a cable tunnel to accommodate the maximum 4.33" (110 mm) wiring conduit per the diagram.

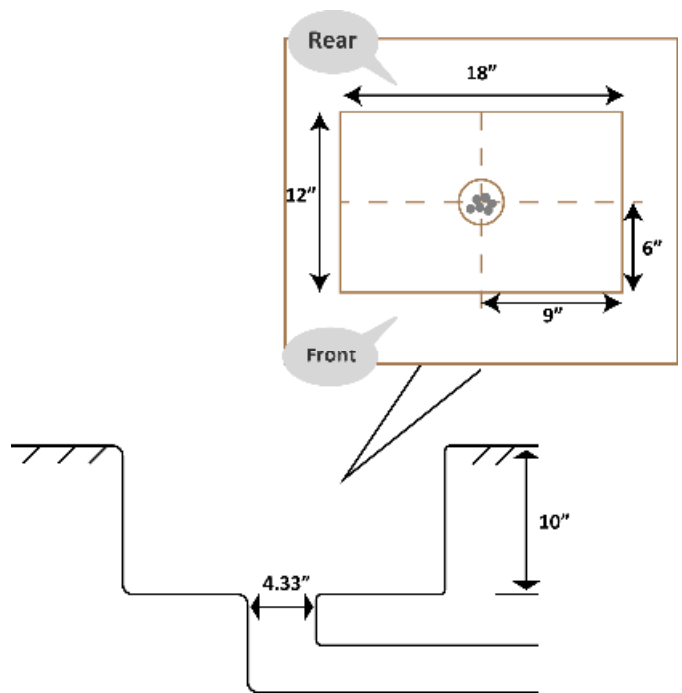

3. Run the conduit to the designated location. The conduit stub-up is recommended minimum 4" (100 mm) above the foundation.
4. Pour wet concrete into the hole and wait until the concrete has hardened.

IMPORTANT

To ensure safe and permanent anchoring, the concrete strength level should be above 3500 PSI.

5. Pull the wiring up through the conduit, leaving 3.3–5 ft. (1–1.5 m) excess length for the remaining installation activities.

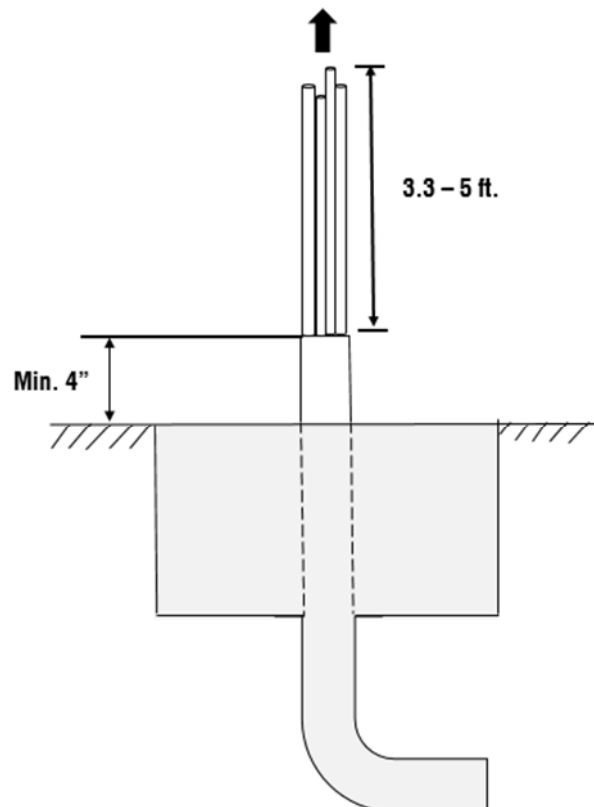

4.2.4 Installing the Pedestal

Step 1

1. Loosen the upper two M5 x 20 security screws using the screwdriver T25 to remove the upper front cover. **Set them aside.**

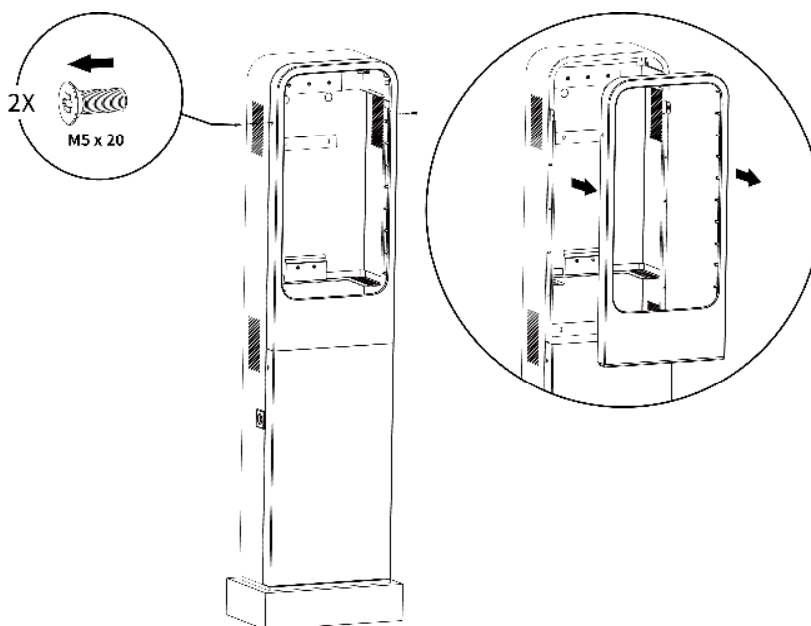

2. Loosen the lower two M5 x 20 security screws using the screwdriver T25 to remove the lower front cover of the pedestal and **set them aside.**

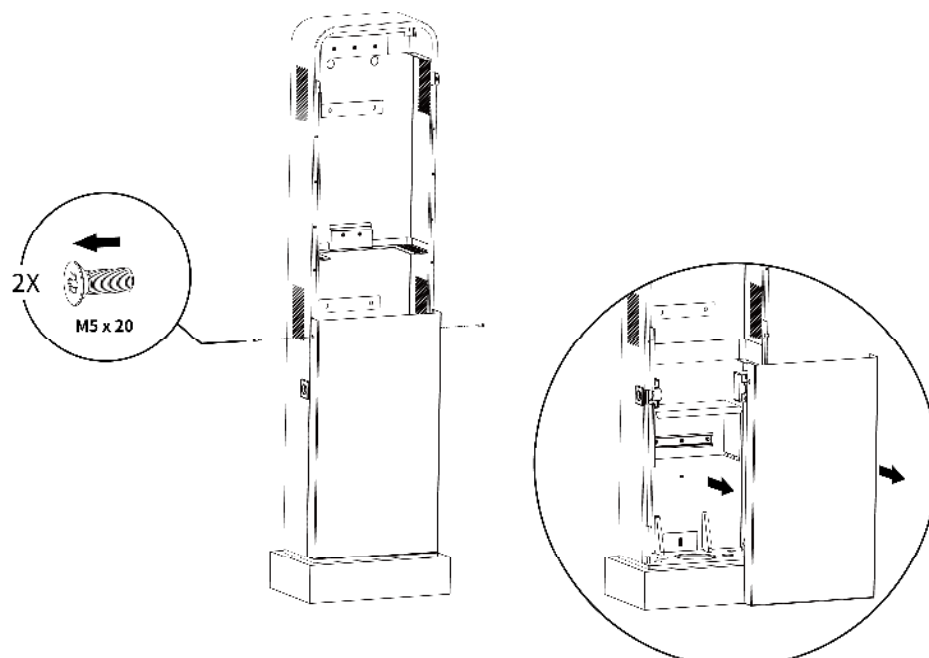

Step 2

1. Place and align the drilling template on the foundation.
2. Mark four mounting holes on the foundation. Remove the drilling template.
3. Drill four holes at the marked location measuring 0.7" (18 mm) in diameter and 6.3" (160 mm) in depth.

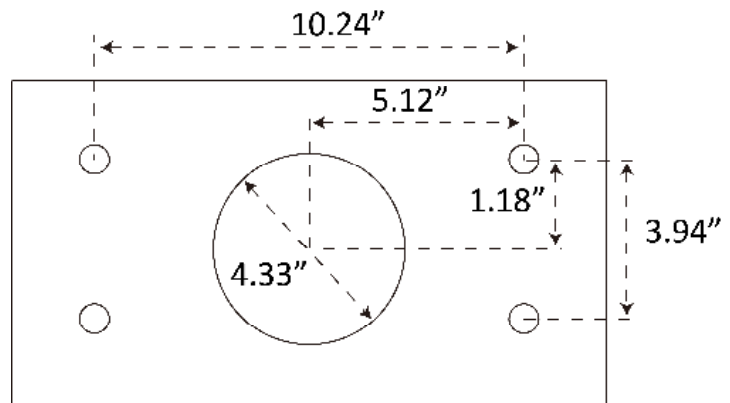

Step 3

1. Mount the wall dock to the mounting location of the pedestal by screwing the three M6 x 16 screws. Tighten them to 4–5 ft/lbs (5–7 Nm) using the socket wrench.

NOTE

The wall dock can also be mounted after the pedestal is secured, but must be mounted prior to installing the charging station.

2. Place the pedestal onto the foundation, aligning the conduit stub-up and the four mounting holes. Use the four expansion bolts (M16 x 150) to anchor the pedestal. Tighten the screws to 103 ft/lbs (140 Nm) using an open spanner (0.94").

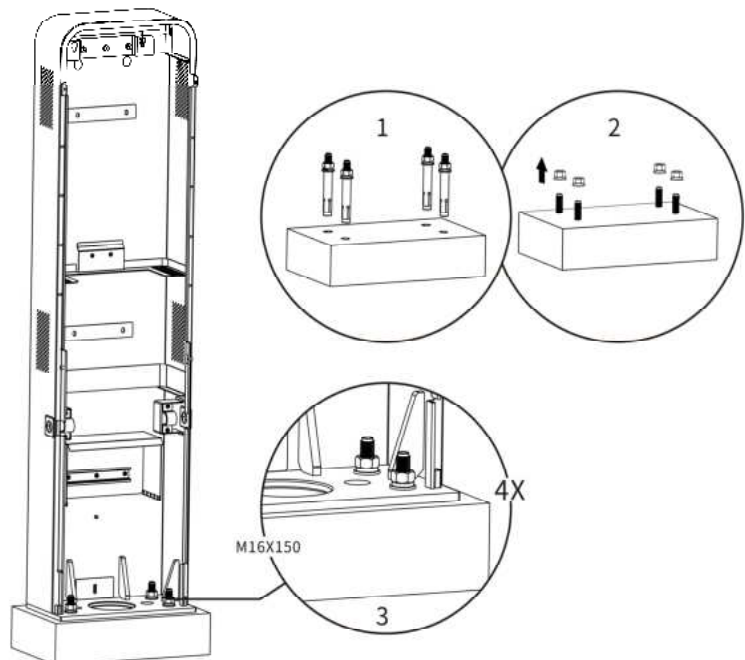

4.2.5 Installing the Charging Station

Step 1

Attach the charging station to the wall dock on the pedestal by inserting the two protruding screws on the back of the charging station into the two mounting holes and slide the charging station downwards.

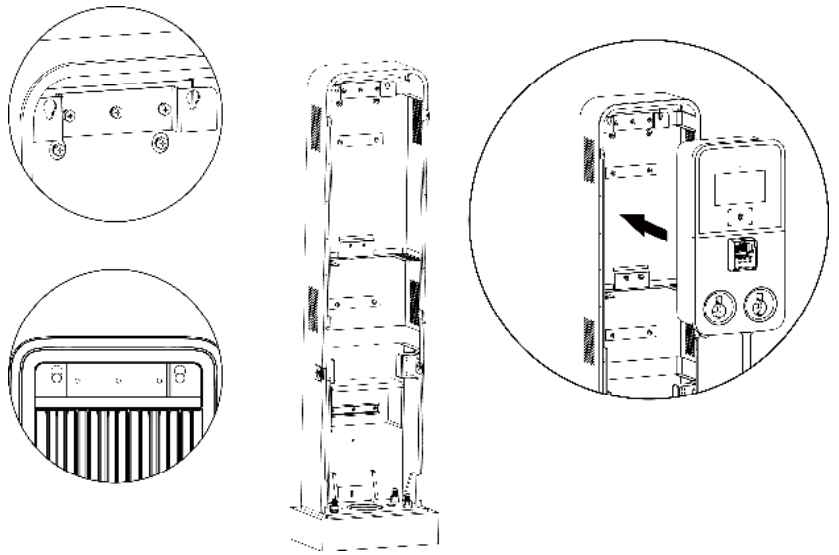

Step 2

1. Loosen the four M4 x 15 screws using a Phillips screwdriver to remove the two strain reliefs temporarily and set them aside.
2. Take out the rubber rings and guide the charging cables through the rings. Reinstall the rubber rings.

NOTE

The openings of the rubber rings must face inside when reinstalling them.

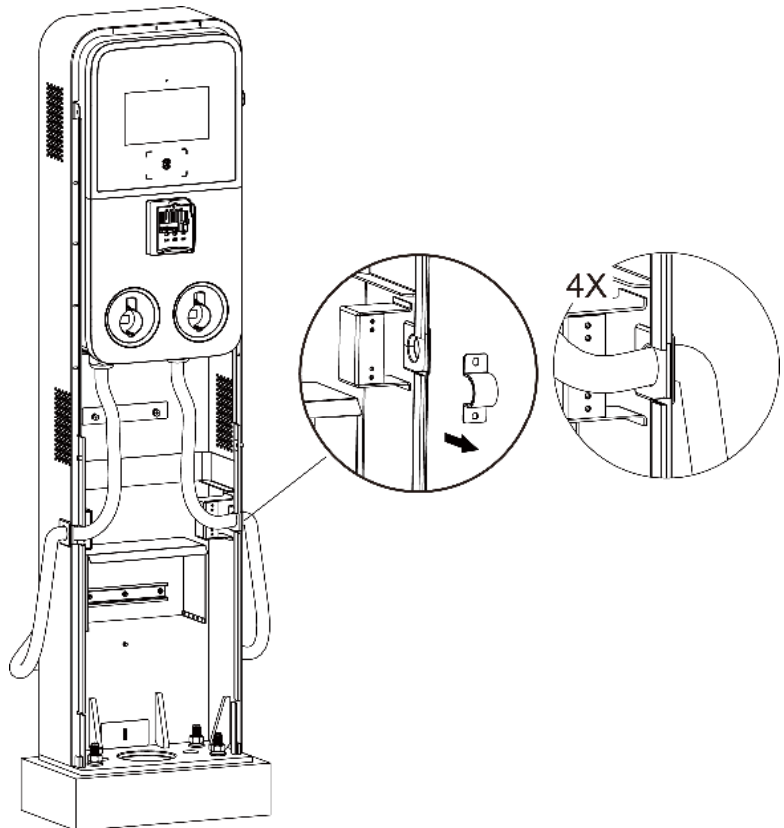

3. Reinstall the strain reliefs by screwing the four M4 x 15 screws and tighten the screws.

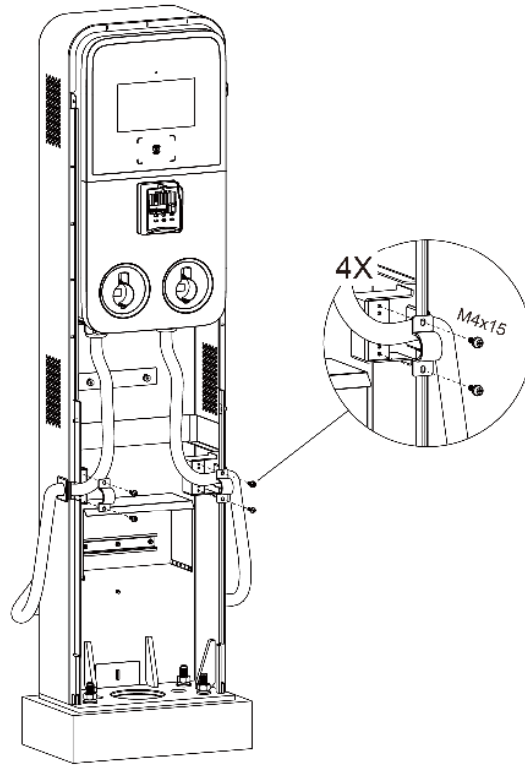

Step 3

1. Loosen the two M3 x 8 screws using the screwdriver T10 and set the screws aside.
2. Remove the faceplate and set it aside.

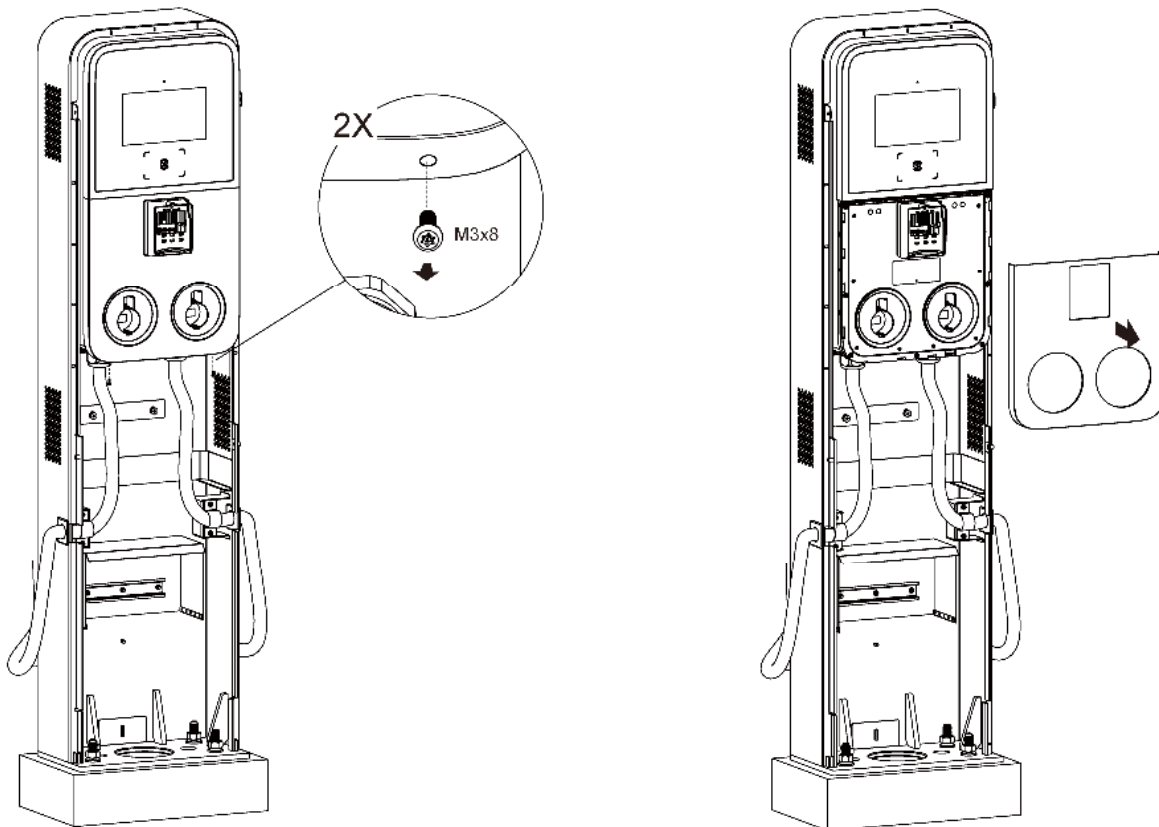

3. Unscrew the eight M3 x 8 screws using the screwdriver T10 and **set the screws aside.**
4. Flip the maintenance cover upward. Next, insert the two M6 x 25 screws into the two holes and tighten them to 4–5 ft/lbs (5–7 Nm) to secure the charging station using the socket wrench.

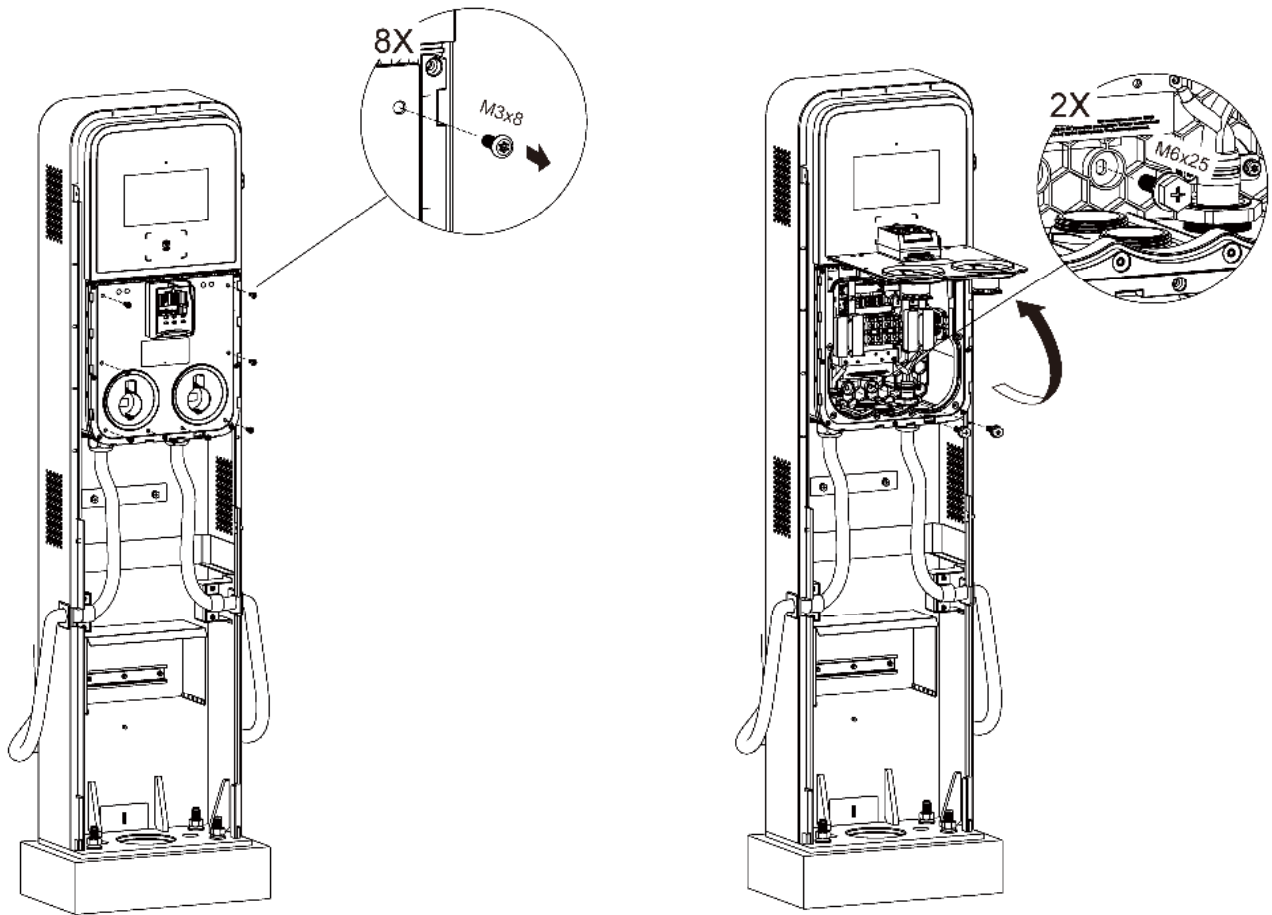

After the above installation steps are finished, you are ready to start AC input wiring. Please refer to **Section 4.5** to proceed.

4.2.6 Completing the Installation

1. Ensure all the installation and wiring are secured and correct. Flip the maintenance cover downward. Reinsert the eight M3 x 8 screws and tighten them.
2. Reinstall the faceplate by reinserting the two M3 x 8 screws and tighten them.

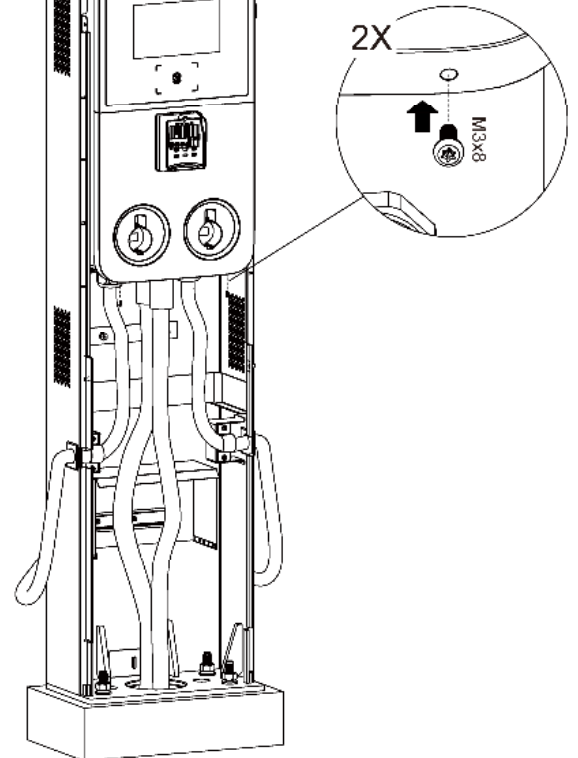
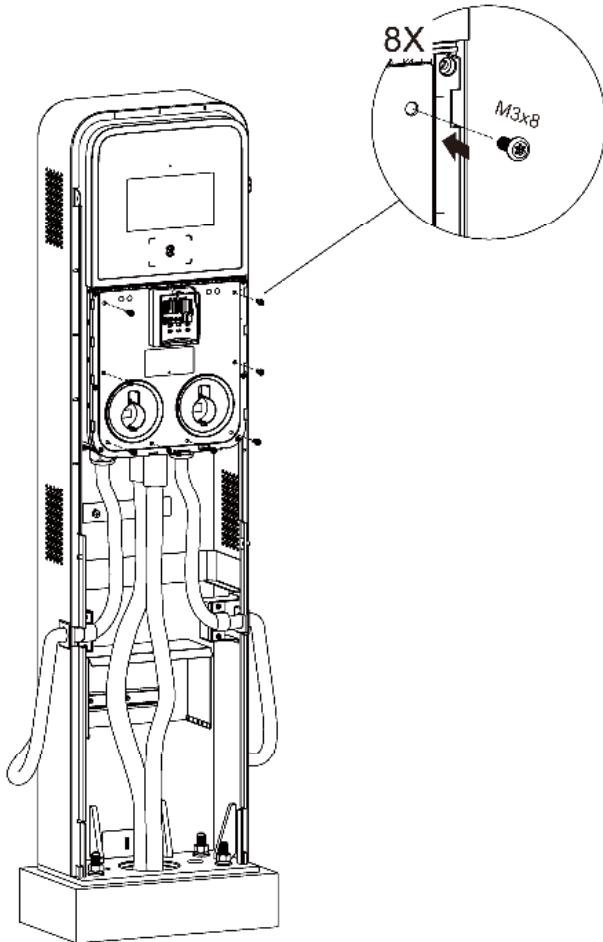

3. Reinstall the lower front cover of the pedestal by screwing the two M5 x 20 security screws and tighten them.
4. Reinstall the upper front cover of the pedestal and secure it with the two M5 x 20 security screws and tighten the screws.

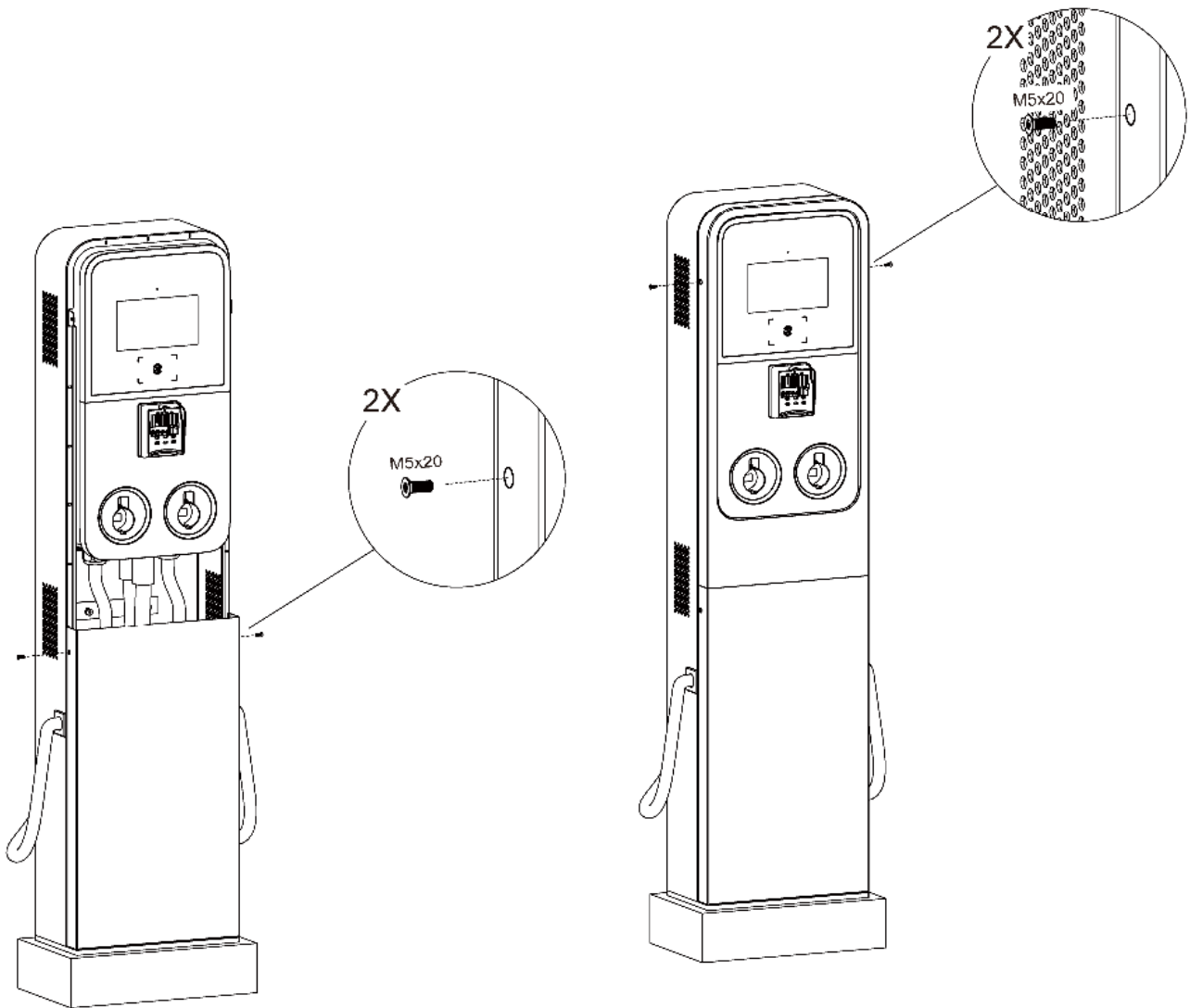





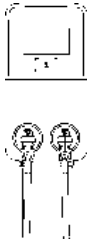

5. Plug the connectors into the holsters and the installation is completed now.

4.3 Charging Station + CMS_Model B

There are two kinds of cable management system in height: **107" (2.72 m)** and **78" (1.97 m)**. For indoor installation, ensure that the space must be tall enough to accommodate the cable management system.



4.3.1 Checking the Box

<p>Charging Station (1 pc)</p>		<p>Wall Dock (1 pc)</p>		<p>Screwdriver T10 (1 pc)</p>	
<p>*M5 x 10 Screw</p>		<p>Screwdriver T25 (1 pc)</p>		<p>Socket Wrench (1 pc)</p>	





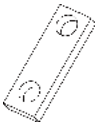



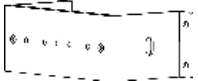
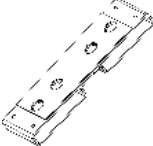

NOTE

- The quantity of M5 x 10 screw for the dual-port MaxiCharger is 4 pcs, 2 pcs for spare use.
- The quantity of M5 x 10 screw for the single-port MaxiCharger is 2 pcs, 1 pc for spare use.

Power Sharing Kit (For the Dual-port MaxiCharger Only)

<p>Double Tee Nut (2 pcs)</p>		<p>Spacer (4 pcs)</p>		<p>M4 x 26 Screw (4 pcs)</p>	
--	---	----------------------------------	---	---	---

Cable Management System Kit

<p>CMS (1 pc)</p>		<p>Drilling Template (1 pc)</p>		<p>Bracket Cover (2 pcs)</p>	
<p>Bracket Base (2 pcs)</p>		<p>Screw (M6 x 16) (11 pcs)</p>		<p>*Locating Pin</p>	
<p>Frame Hole Cover (2 pcs)</p>		<p>Hole Plug (4 pcs)</p>		<p>Screw (M6 x 25) (2 pcs)</p>	
<p>Screw (M6 x 50) (8 pcs)</p>		<p>Wall Anchor (8 pcs)</p>			

NOTE

- The quantity of locating pin for the dual-port MaxiCharger is 2 pcs.
- The quantity of locating pin for the single-port MaxiCharger is 1 pc.

4.3.2 Installation Tools (Not Included)

Prepare the following installation tools:

- Tape Measure
- Spirit Level
- Marker
- Drill
- Drill Bit, 0.31" (8 mm)
- Phillips Screwdriver
- Wire Stripper
- Crimping Tool
- Flathead Screwdriver
- Cable Lug (Recommended: EVN25-16 for L1&L2/N wire; RNB8-6S for PE wire)

 **NOTE**

- The tools mentioned above are not provided. Be sure to have all the tools ready prior to installation.
 - This tool list does not necessarily include all the tools you may need.
-

4.3.3 Installing the CMS

Step 1

1. Place the drilling template against the wall and level it using a spirit level.
2. Mark eight holes. Remove the drilling template.
3. Drill the eight holes at the marked locations measuring 0.31" (8 mm) in diameter and 2.36" (60 mm) in depth on the wall.
4. Insert the included eight wall anchors into the holes.

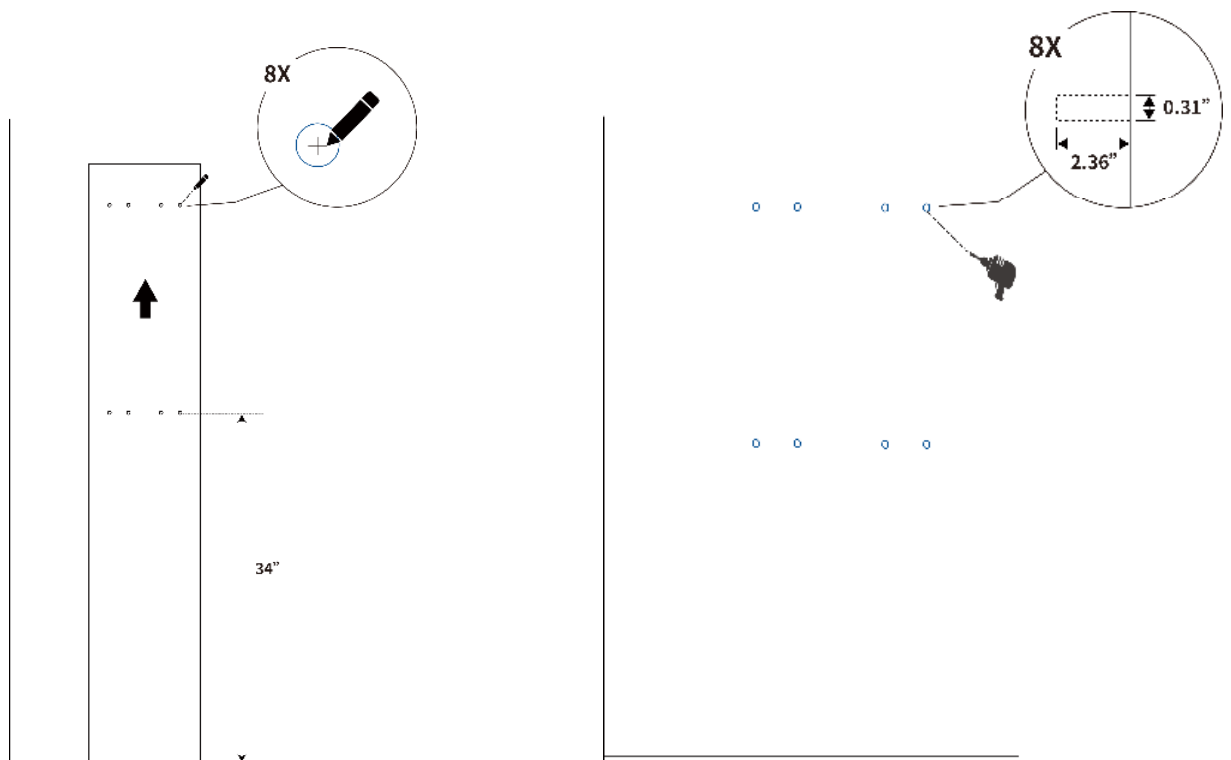

Step 2

1. Attach the two bracket bases to the wall using the eight M6 x 50 screws. Use the socket wrench to tighten the screws to a torque of 4–5 ft/lbs (5–7 Nm).

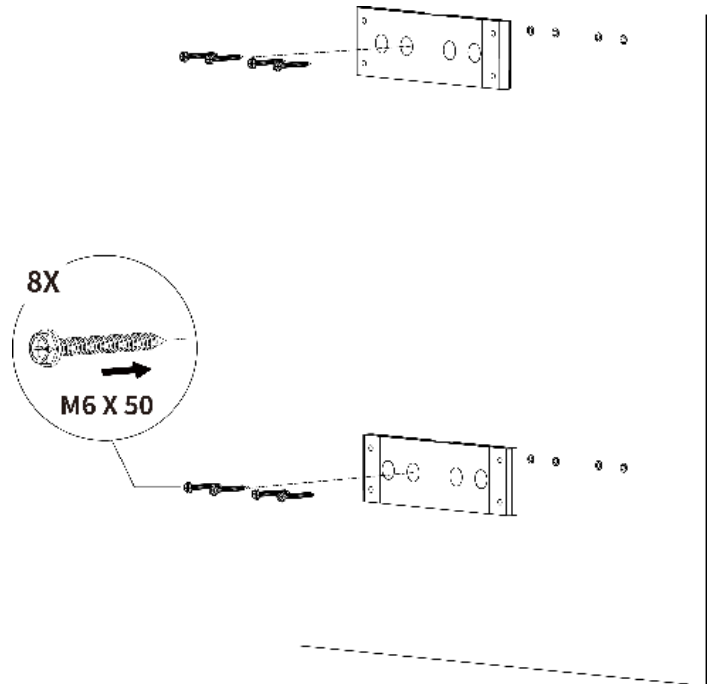

2. Put the CMS in place and use the bracket covers to secure it to the bracket bases. Ensure the cable clamp strings are avoided.
3. Insert the eight M6 x 16 screws and tighten them to a torque of 4–5 ft/lbs (5–7 Nm) using the socket wrench.

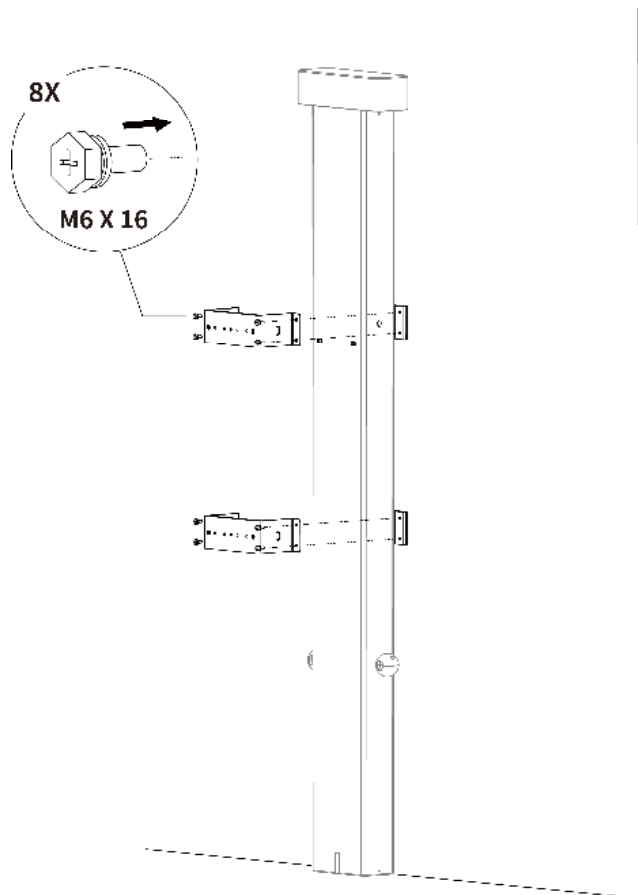

4.3.4 Installing the Charging Station

Step 1

1. Attach the wall dock to the upper bracket cover using the three M6 x 16 screws as shown in the diagram.
2. Tighten them to 4–5 ft/lbs (5–7 Nm) using the socket wrench.

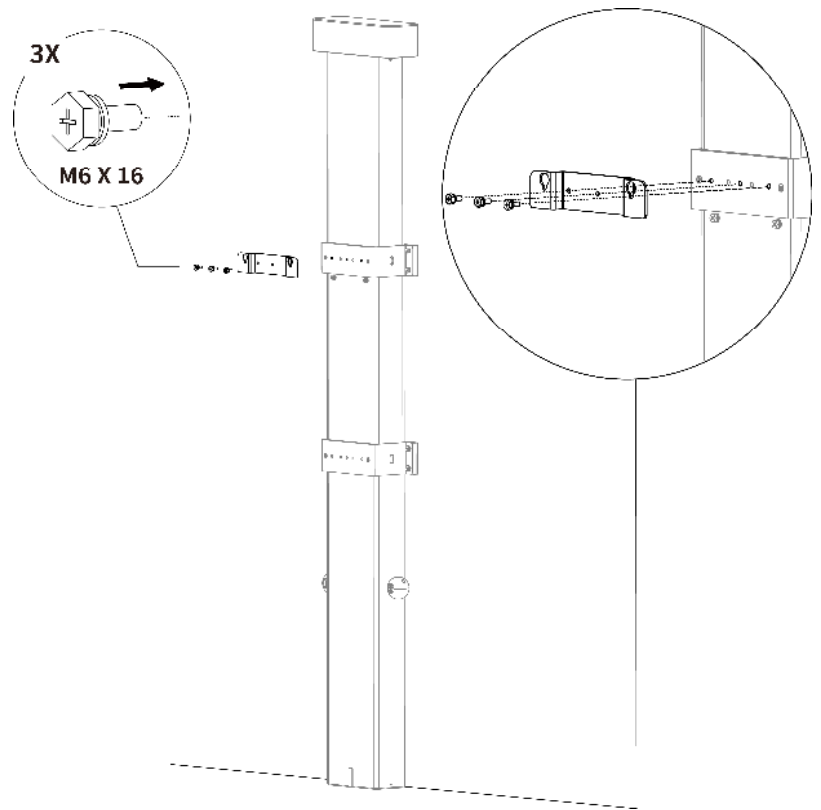

Step 2

1. Insert the two locating pins from both sides.
2. Remove the two M6 x 30 screws using a Phillips screwdriver in the front.

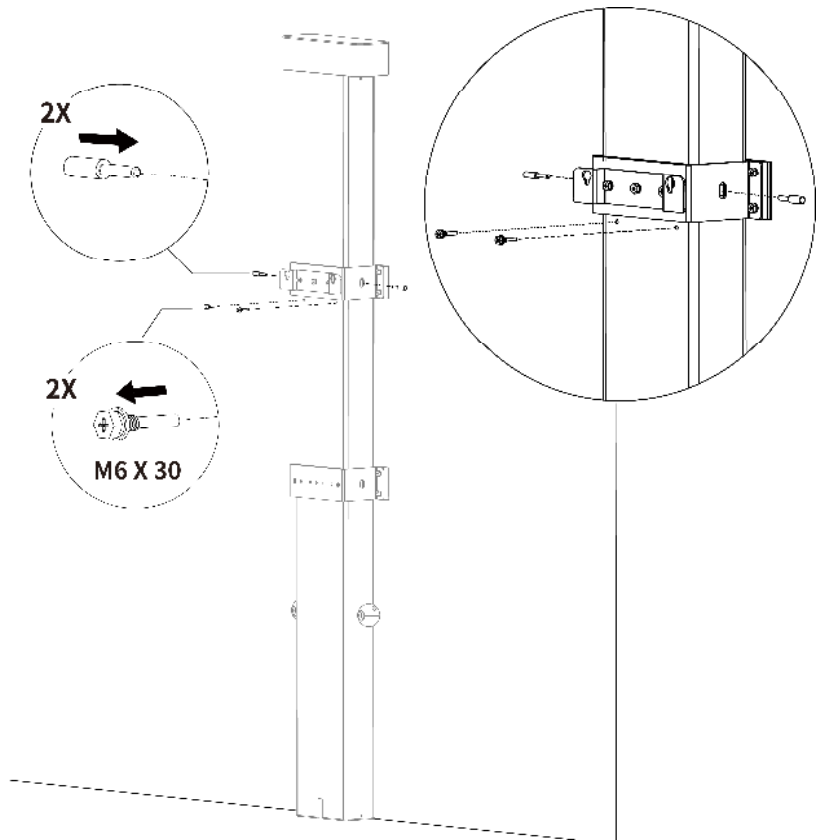

Step 3

1. Attach the charging station to the wall dock by inserting the two protruding screws on the back of the charging station into the two upper mounting holes and slide the charging station downwards.

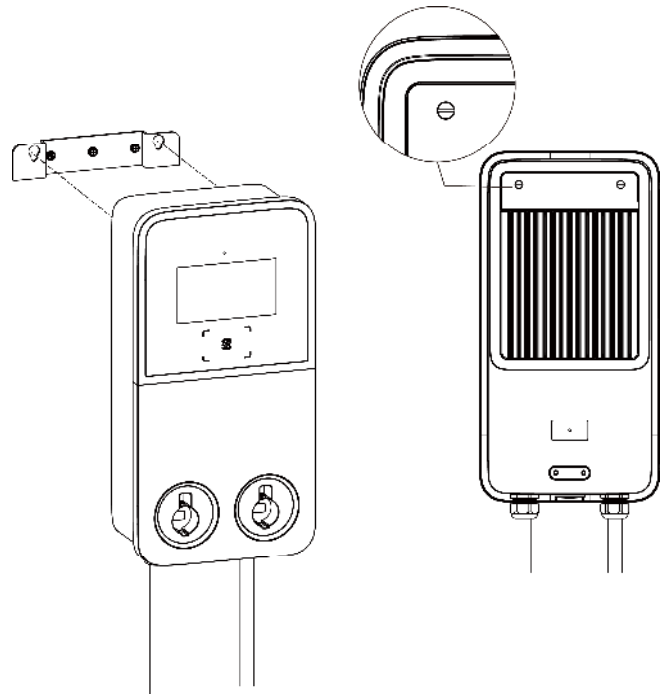

2. Loosen the screws of the cable clamps (two M3 x 10 screws each) using a Phillips screwdriver to detach the clamps.

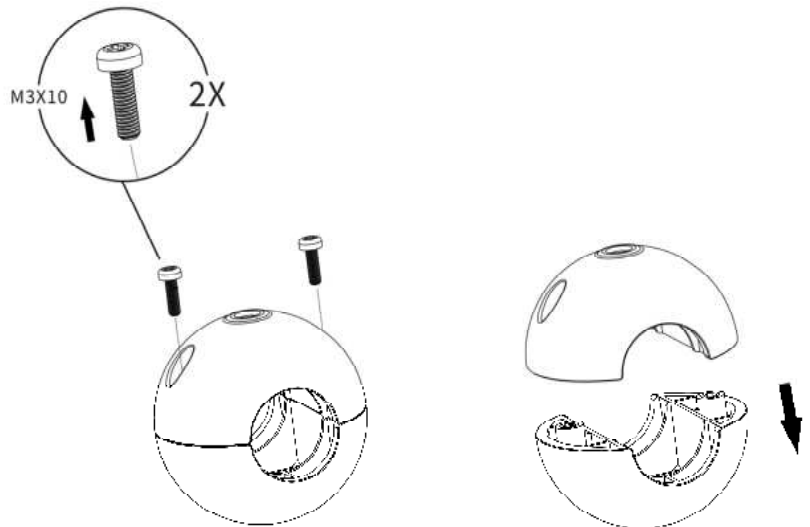

3. Locate the recommended hanging point by either of the following two methods:

- a) If needed, mark the hanging point (metering from the connector) on the charging cable according to the table.
- b) Find the hanging point label on the charging cable if applicable.

Charging Cable's Length	Distance between Hanging Point and Connector (H)
25.16' (7.67 m)	12.47' (3.8 m)
24.61' (7.5 m)	11.15' (3.4 m)
20.24' (6.17 m)	10.17' (3.1 m)
16.4' (5 m)	7.55' (2.3 m)

4. Position the mark on the charging cable under the upper clamp.
5. Reinstall the lower clamp and tighten the screws.

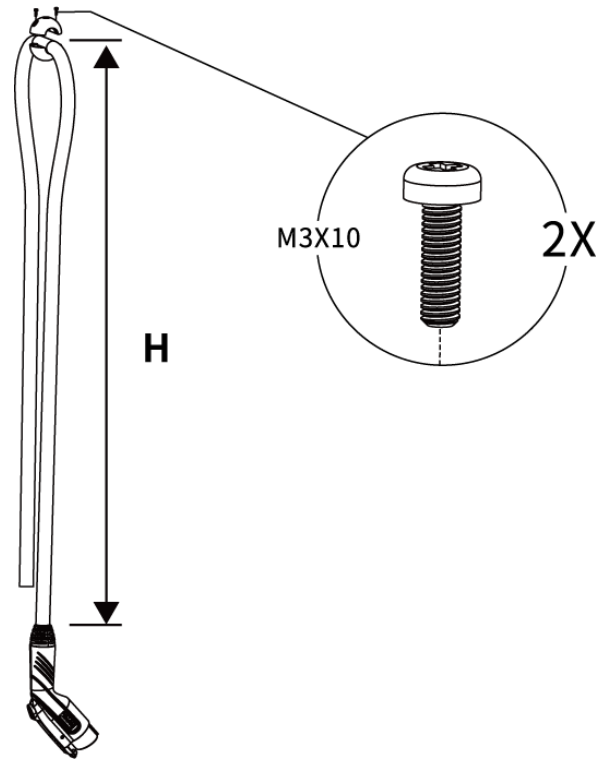

6. Remove the two locating pins from the CMS.

NOTE

After the locating pins are removed, the CMS's counterweights are relieved to move up and down.

7. Use the hole plugs to seal the locating pin holes.

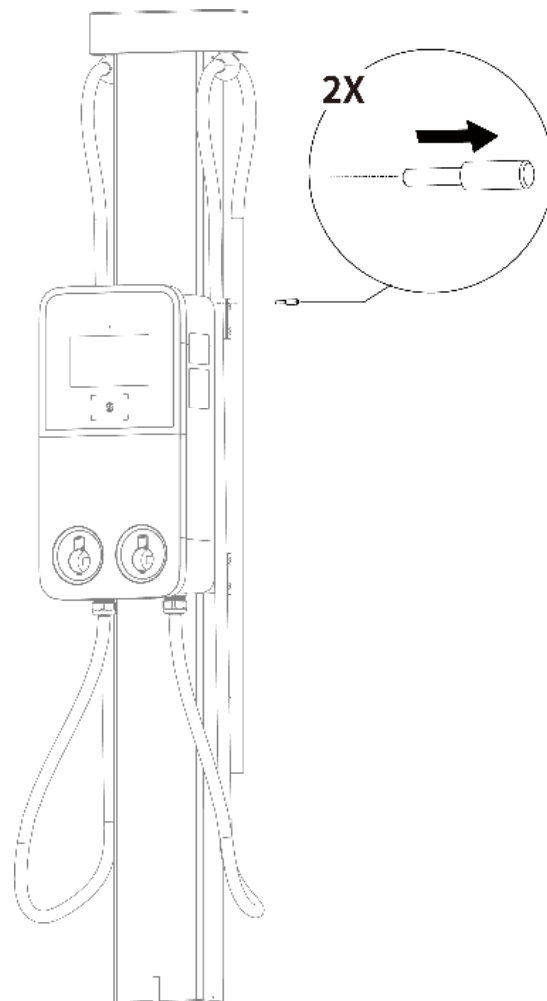

8. Loosen the two M3 x 8 screws using the screwdriver T10 and remove the faceplate. **Set them aside.**

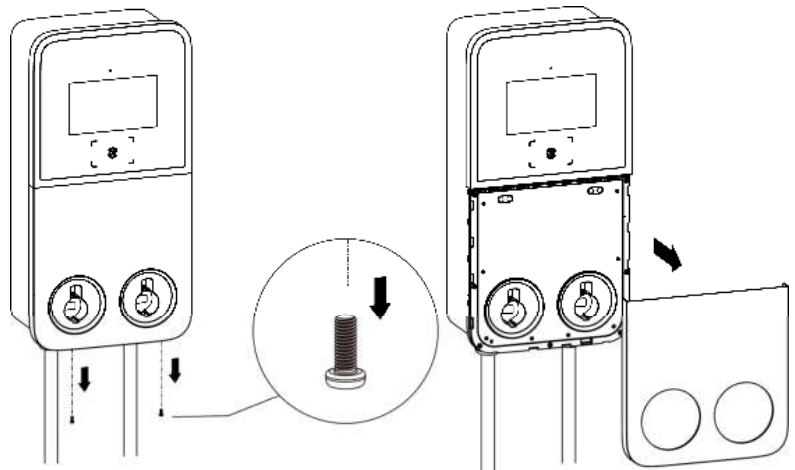

9. Unscrew the eight M3 x 8 screws using the screwdriver T10. **Set the screws aside.**

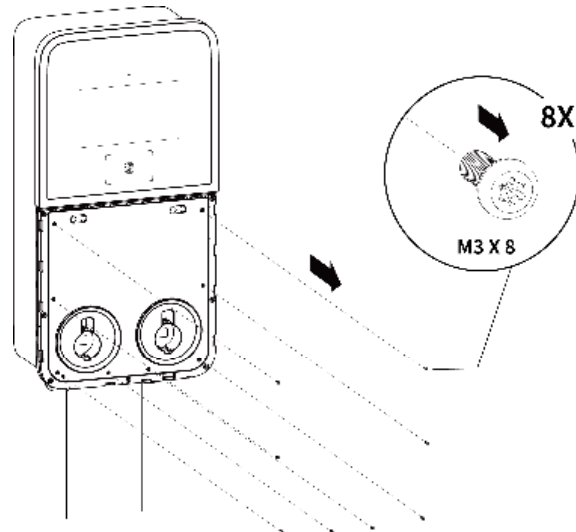

10. Flip the maintenance cover upward. Next, insert the two M6 x 50 screws and tighten them to 4–5 ft/lbs (5–7 Nm) using the socket wrench to secure the charging station.

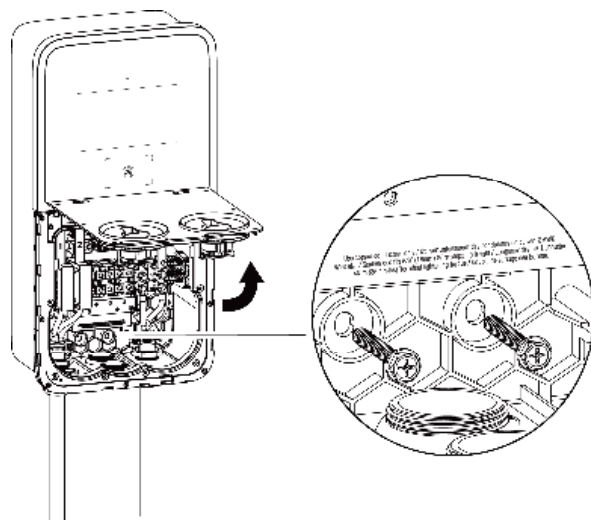

After the above installation steps are finished, you are ready to start AC input wiring. Please refer to **Section 4.5** to proceed.

4.3.5 Completing the Installation

1. Ensure all the installation and wiring are secured and correct. Next, flip the maintenance cover downward. Reinsert the eight M3 x 8 screws and tighten them.

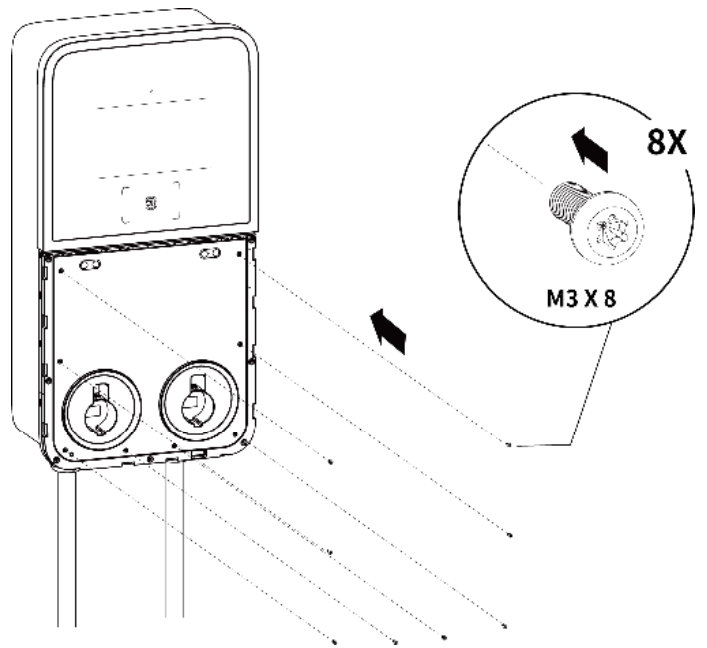

2. Reinstall the faceplate using the two M3 x 8 screws and tighten them accordingly.
3. Plug the connectors into the holsters. The installation is completed now.

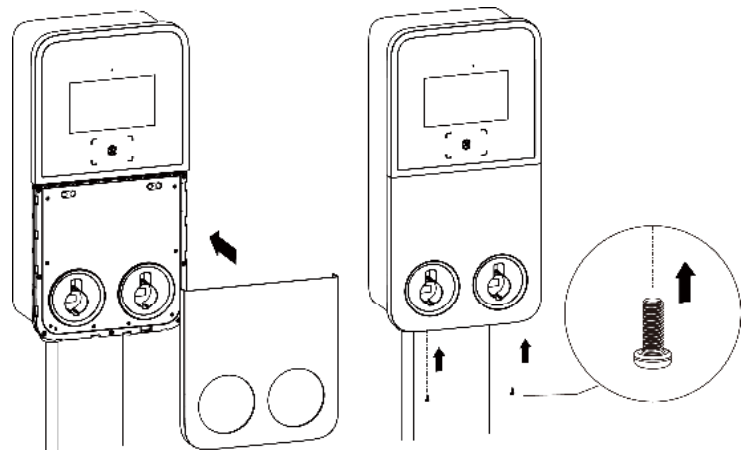





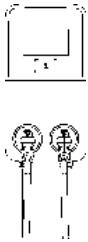

4.4 Charging Station + Pedestal + CMS

There are two kinds of cable management system in height: **107" (2.72 m)** and **78" (1.97 m)**. For indoor installation, ensure that the space must be tall enough to accommodate the cable management system.

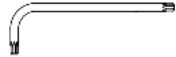
4.4.1 Checking the Box



Ensure the following items can be found in the package.

Charging Station (1 pc)		Wall Dock (1 pc)		Screwdriver T10 (1 pc)	
*M5 x 10 Screw		Screwdriver T25 (1 pc)		Socket Wrench (1 pc)	





NOTE

- The quantity of M5 x 10 screw for the dual-port MaxiCharger is 4 pcs, 2 pcs for spare use.
- The quantity of M5 x 10 screw for the single-port MaxiCharger is 2 pcs, 1 pc for spare use.

Power Sharing Kit (For the Dual-port MaxiCharger Only)

Double Tee Nut (2 pcs)		Spacer (4 pcs)		M4 x 26 Screw (4 pcs)	
----------------------------------	---	--------------------------	---	---------------------------------	---

Pedestal Kit

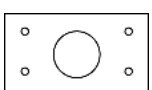







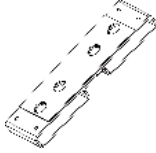

Pedestal (1 pc)		M16 x 150 Expansion Bolt (4 pcs)		M6 x 25 Screw (2 pcs)	
M6 x 16 Screw (7 pcs)		Drilling Template (1 pc)			

Cable Management System Kit

CMS_Model A

<p>CMS (1 pc)</p>	
------------------------------	---

CMS_Model B

<p>CMS (1 pc)</p>		<p>Drilling Template (1 pc)</p>		<p>Bracket Cover (2 pcs)</p>	
<p>Bracket Base (2 pcs)</p>		<p>Screw (M6 x 16) (11 pcs)</p>		<p>*Locating Pin</p>	
<p>Frame Hole Cover (2 pcs)</p>		<p>Hole Plug (4 pcs)</p>		<p>Screw (M6 x 25) (2 pcs)</p>	
<p>Screw (M6 x 50) (8 pcs)</p>		<p>Wall Anchor (8 pcs)</p>			

NOTE

- The quantity of locating pin for the dual-port MaxiCharger is 2 pcs.
- The quantity of locating pin for the single-port MaxiCharger is 1 pc.

4.4.2 Installation Tools (Not Included)

Prepare the following installation tools:

- Scoop Shovel (for digging a hole)
- Marker
- Drill
- Drill Bit, 0.71" (18 mm)
- Open Spanner, 0.94" (24 mm)
- Phillips Screwdriver
- Wire Stripper
- Crimping Tool
- Cable Lug (Recommended: EVN25-16 for L1&L2/N wire; RNB8-6S for PE wire)
- Flathead Screwdriver

NOTE

- The tools mentioned above are not provided. Be sure to have all the tools ready prior to installation.
 - This tool list does not necessarily include all the tools you may need.
-

4.4.3 Preparing a Foundation

1. Dig a hole according to the foundation dimensions. The recommended dimensions of the hole are 18" x 18" x 10" (460 x 460 x 250 mm) (W x D x H).

IMPORTANT

- A flat and structurally sound concrete foundation is required for installation.
 - The foundation is recommended to be flush with ground.
-

2. Trench and excavate a cable tunnel to accommodate the maximum 4.33" (110 mm) wiring conduit per the diagram.

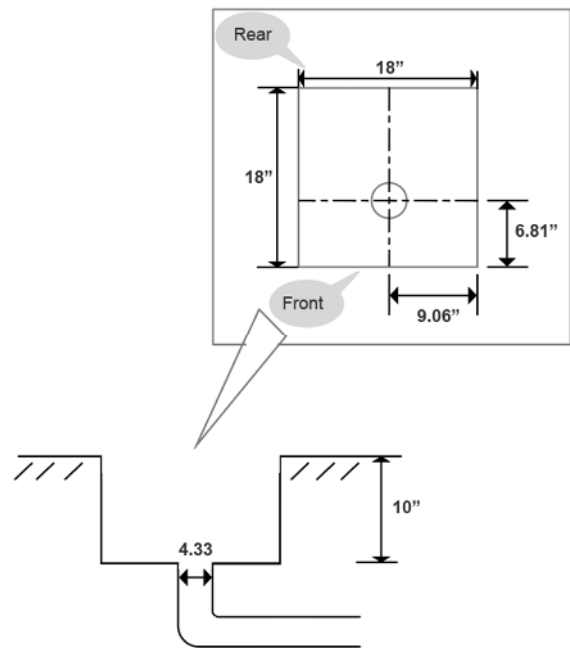

3. Run the conduit to the designated location. The conduit stub-up is recommended minimum 4" (100 mm) above the foundation.
4. Pour wet concrete into the hole and wait until the concrete has hardened.

IMPORTANT

To ensure safe and permanent anchoring, the concrete strength level should be above 3500 PSI.

5. Pull the wiring up through the conduit, leaving 3.3–5 ft. (1–1.5 m) excess length for the remaining installation activities.

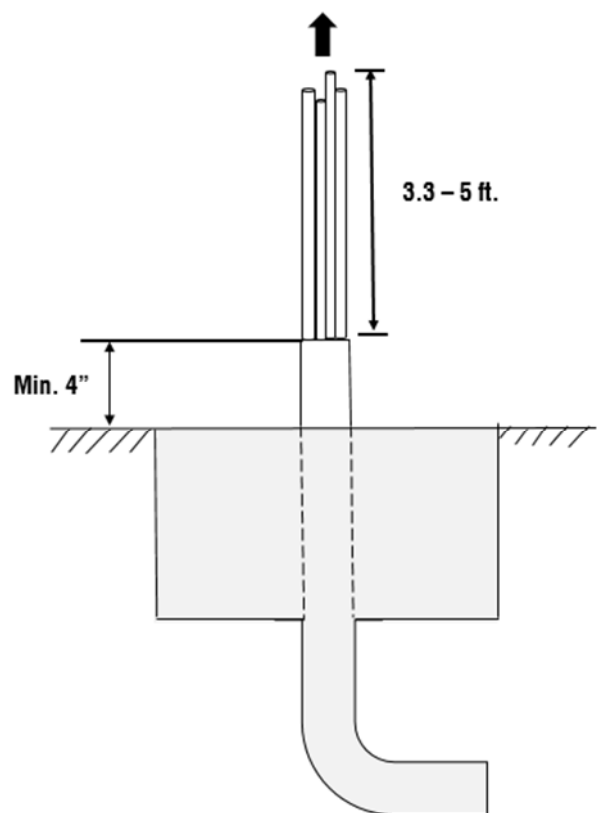

4.4.4 Installing the Pedestal

Step 1

1. Loosen the upper two M5 x 20 security screws using the screwdriver T25 to remove the upper front cover. **Set them aside.**

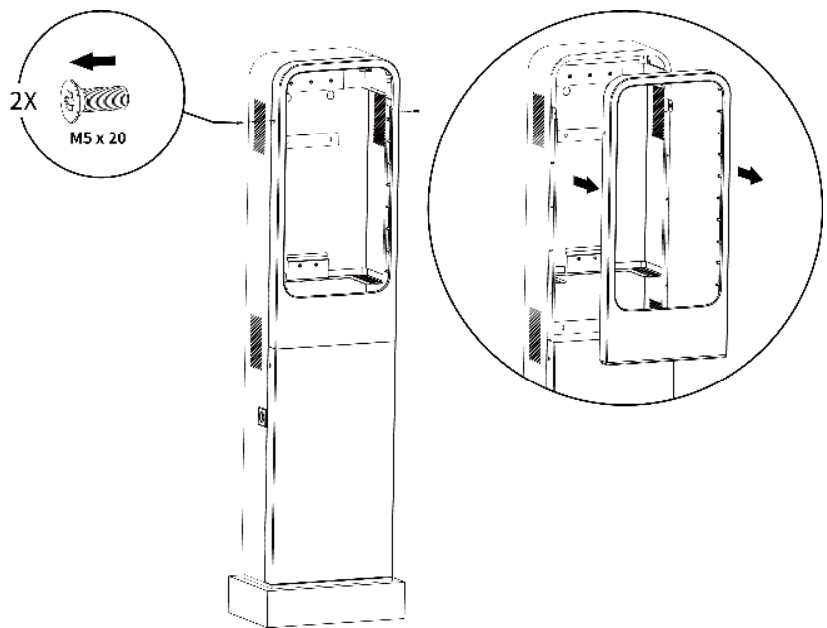

2. Loosen the lower two M5 x 20 security screws using the screwdriver T25 to remove the lower front cover of the pedestal and **set them aside.**

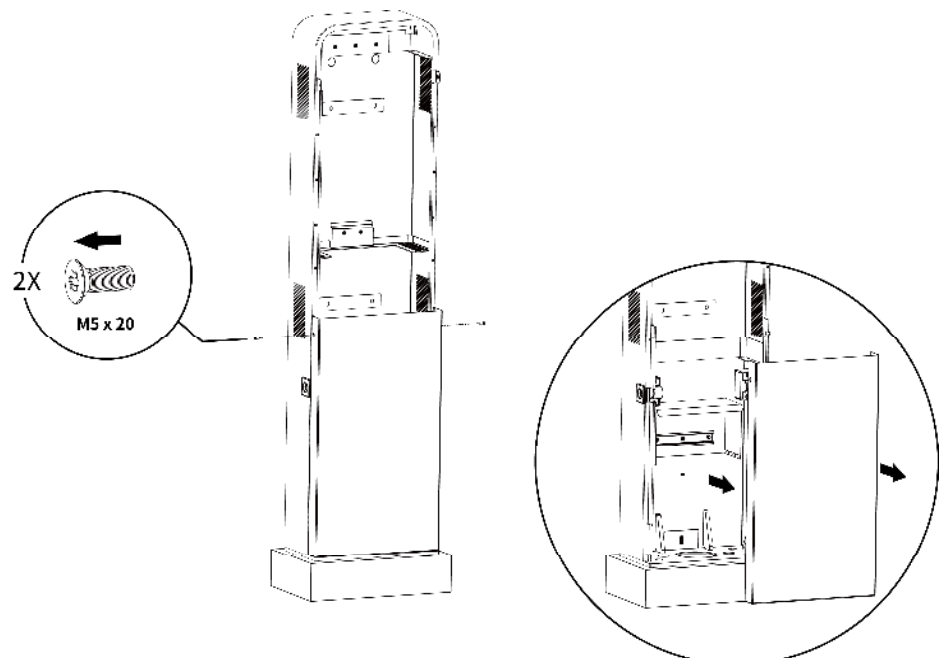

Step 2

1. Place and align the drilling template on the foundation.
2. Mark four mounting holes on the foundation. Remove the drilling template.
3. Drill the four holes at the marked location measuring 0.7" (18 mm) in diameter and 6.3" (160 mm) in depth.

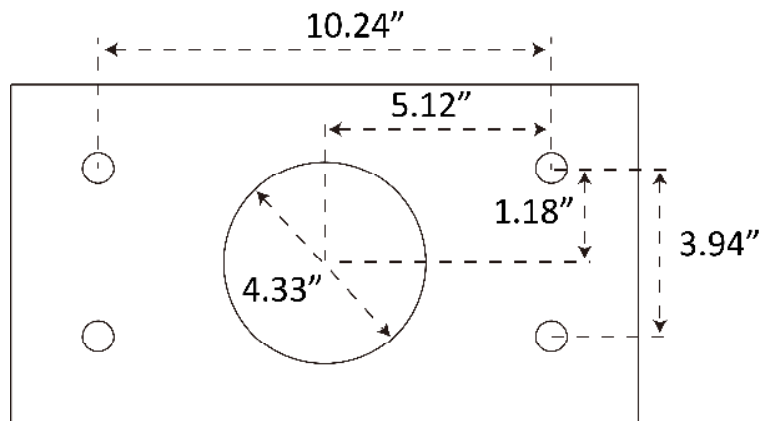

Step 3

1. Mount the wall dock to the mounting location of the pedestal by screwing the three M6 x 16 screws. Tighten them to 4–5 ft/lbs (5–7 Nm) using the socket wrench.

NOTE

The wall dock can also be mounted after the pedestal is secured, but must be mounted prior to installing the charging station.

2. Place the pedestal onto the foundation, aligning with the conduit stub-up and the four mounting holes. Use the four expansion bolts (M16 x 150) to anchor the pedestal. Tighten the screws to 103.26 ft/lbs (140 Nm) using an open spanner (0.94").

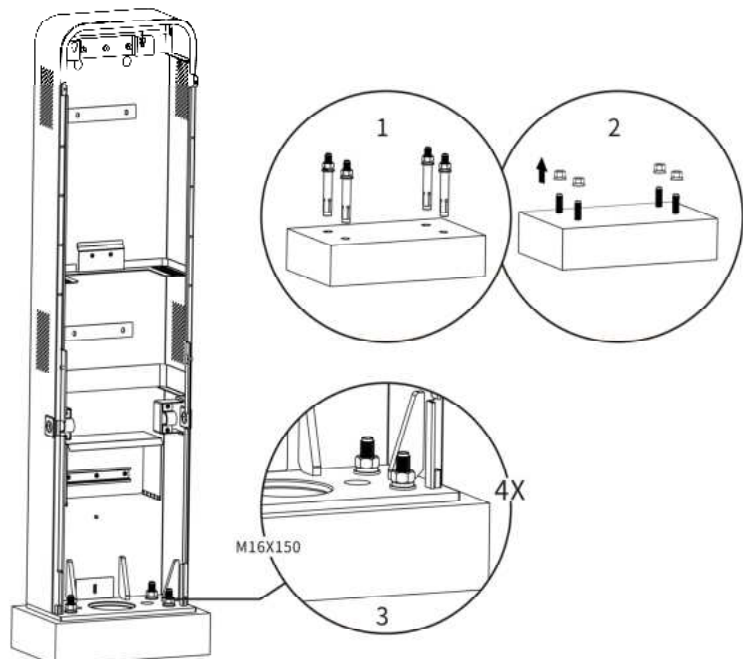

4.4.5 Installing the Cable Management System (CMS)_Model A (Optional)

Step 1

1. Place the CMS on the back of the pedestal, aligning the slot (A) on the bottom of the CMS to the knob (B) on the bottom of the pedestal.
2. Insert the four M6 x 16 screws into the four holes and tighten them using the socket wrench to secure the CMS.

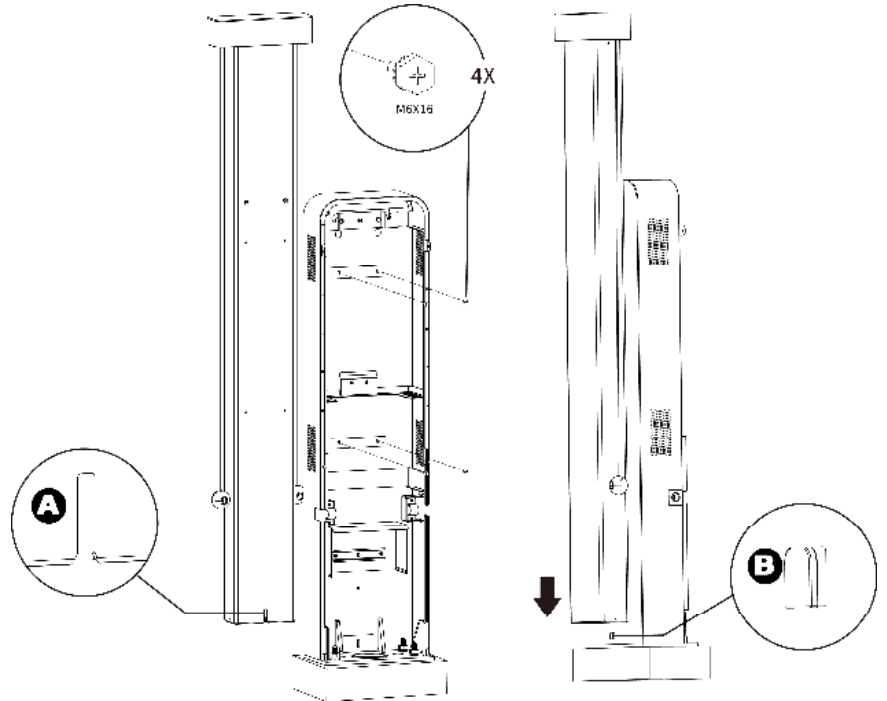

Step 2

1. Loosen the screws of the cable clamps (two M3 x 10 screws each) using a Phillips screwdriver to detach the clamps.

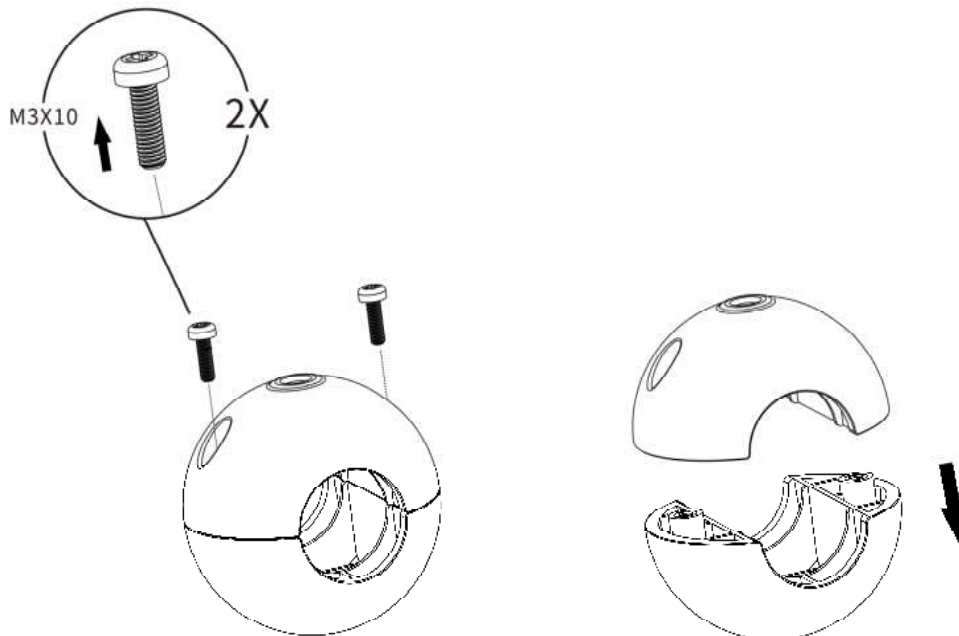

2. Locate the recommended hanging point by either of the following two methods:

- a) If needed, mark the hanging point (metering from the connector) on the charging cable according to the table.
- b) Find the hanging point label on the charging cable if applicable.

Charging Cable's Length	Distance between Hanging Point and Connector (H)
25.16' (7.67 m)	12.47' (3.8 m)
24.61' (7.5 m)	11.15' (3.4 m)
20.24' (6.17 m)	10.17' (3.1 m)
16.4' (5 m)	7.55' (2.3 m)

3. Position the mark on the charging cable under the upper clamp.

4. Reinstall the lower clamp and tighten the screws.

5. Remove the two shipping screws (M6 x 30) using a Phillips screwdriver from the CMS.

NOTE

After the shipping screws are removed, the charging cables may be pulled up suddenly. Be careful there is no harm to the charger and cables.

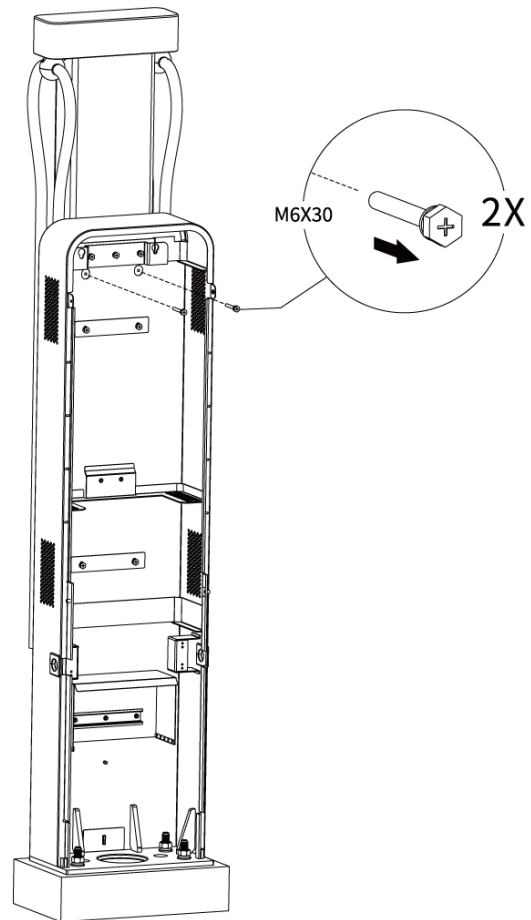
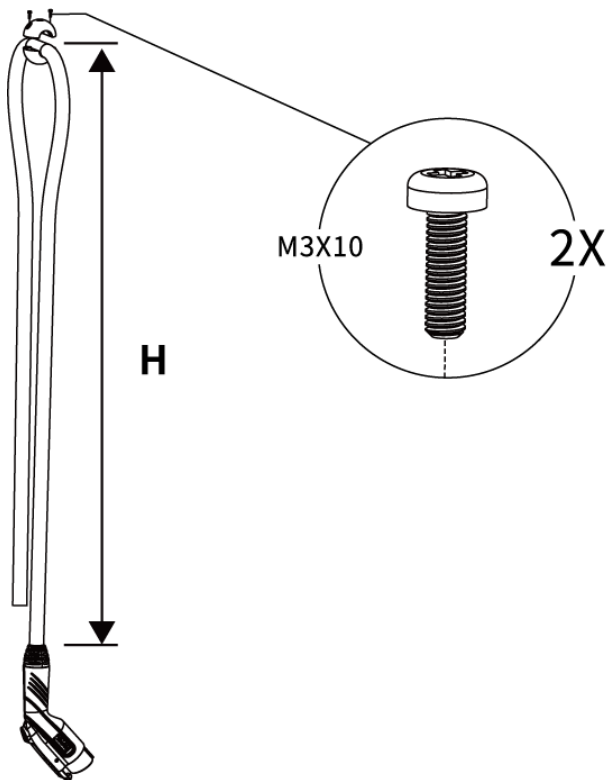

4.4.6 Installing the Cable Management System (CMS)_Model B (Optional)

1. Place the CMS on the back of the pedestal, aligning the slot (A) on the bottom of the CMS to the knob (B) on the bottom of the pedestal.

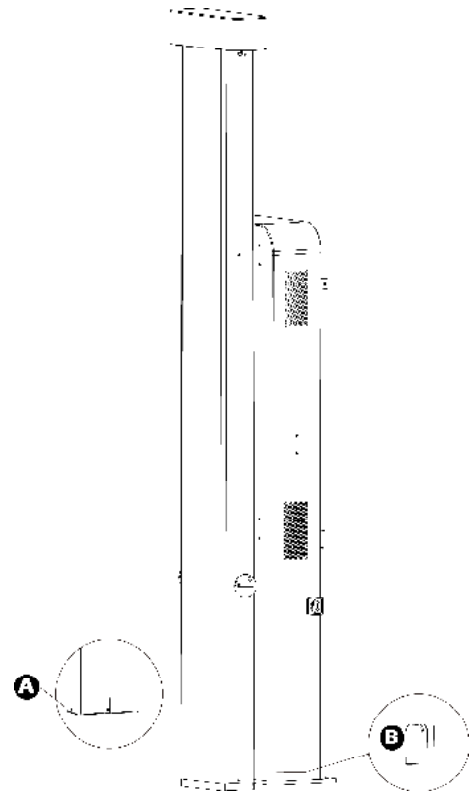

2. Attach the two bracket covers to the CMS using the eight M6 x 16 screws. Tighten the screws to 4–5 ft/lbs (5–7 Nm) using the socket wrench.

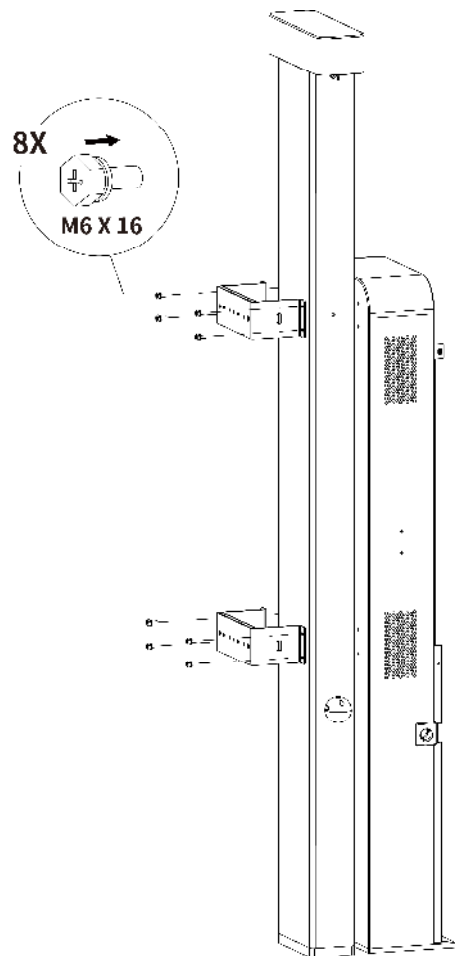

3. Insert the two locating pins from both sides.

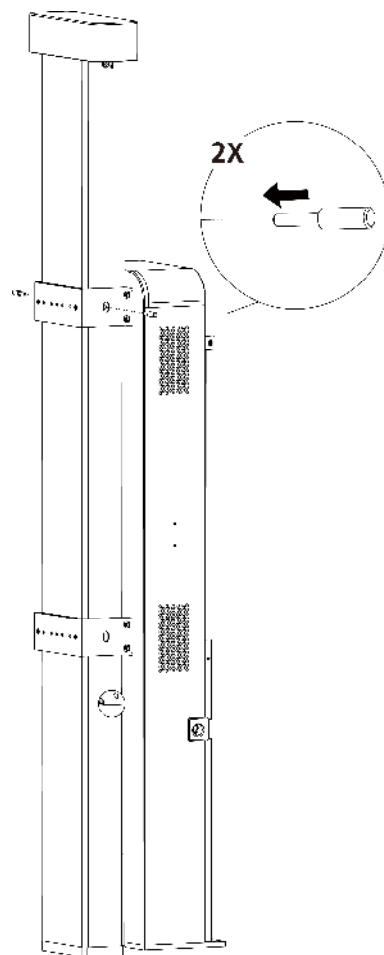

4. Remove the two M6 x 30 screws in the front using a Phillips screwdriver.

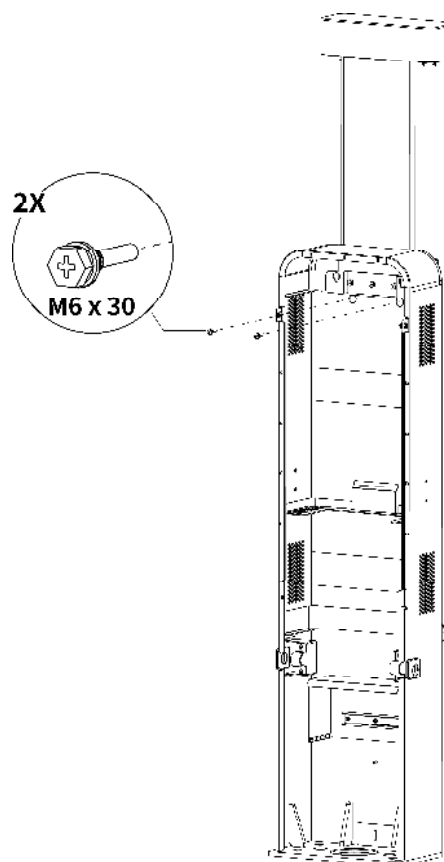

4.4.7 Installing the Charging Station

Step 1

Attach the charging station to the wall dock on the pedestal by inserting the two protruding screws on the back of the charging station into the two mounting holes and slide the charging station downwards.

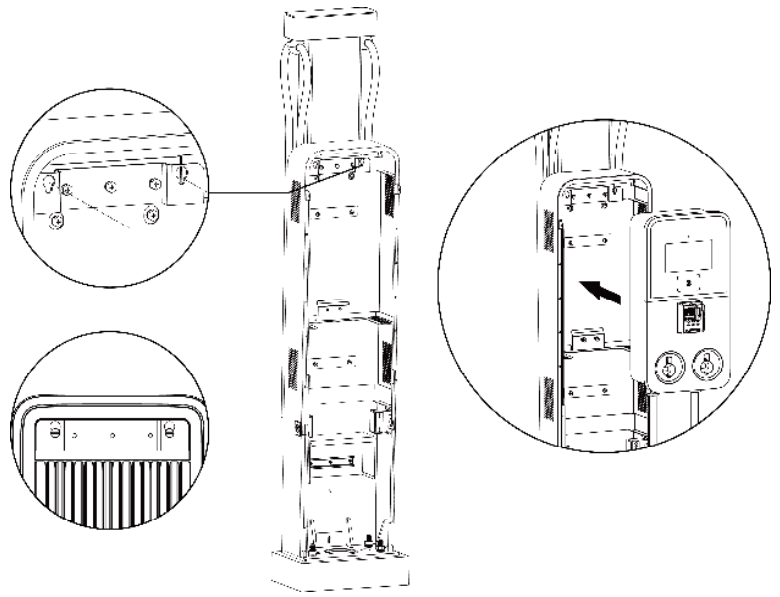

Step 2

1. Loosen the four M4 x 15 screws using a Phillips screwdriver to remove the two strain reliefs temporarily and **set them aside**.
2. Take out the rubber rings and guide the charging cables through the rings. Reinstall the rubber rings.

NOTE

The openings of the rubber rings must face inside when reinstalling them.

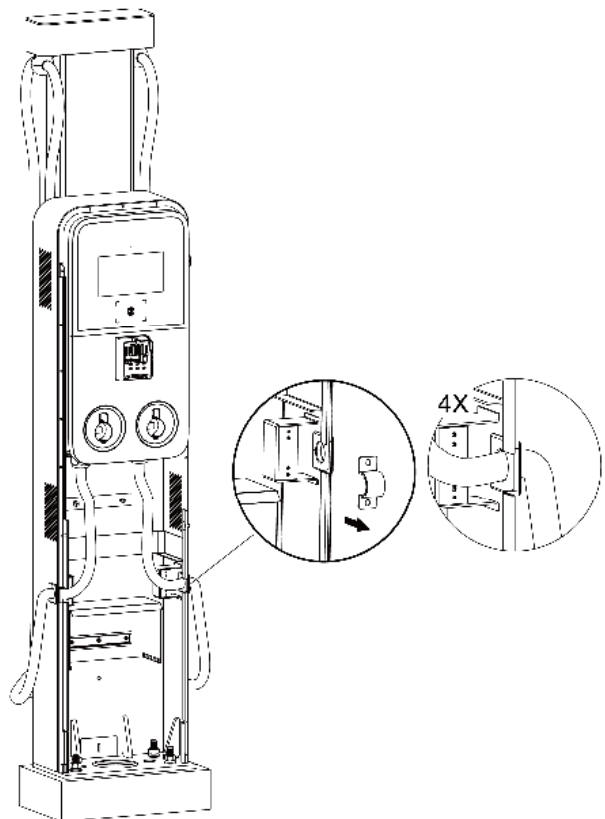

3. Reinstall the strain reliefs by screwing and tightening the four M4 x 15 screws.
4. Hang the charging cable to the cable clamp. See **Step 2 (1-4)** in the **Section 4.4.5** for details. **Cable Management System_Model B only.**
5. Remove the locating pins from the CMS. **Cable Management System_Model B only.**

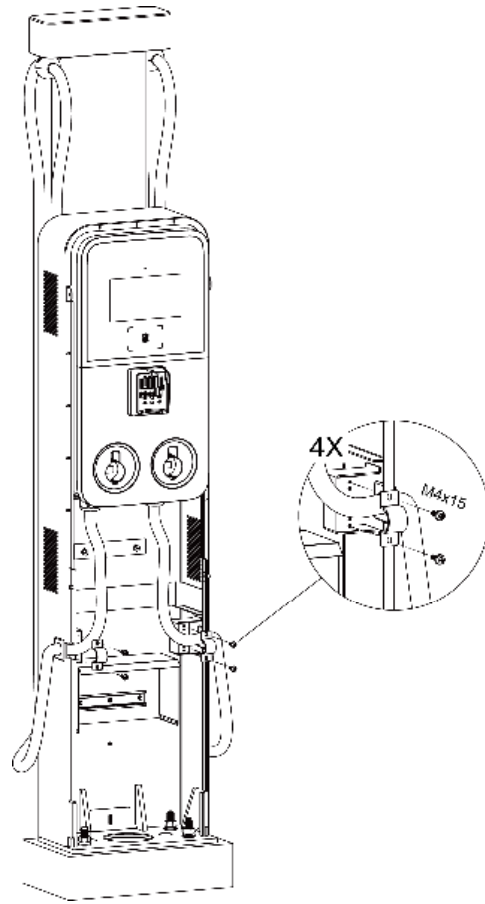

Step 3

1. Loosen the two M3 x 8 screws using the screwdriver T10 and **set the screws aside.**
2. Remove the faceplate and **set it aside.**

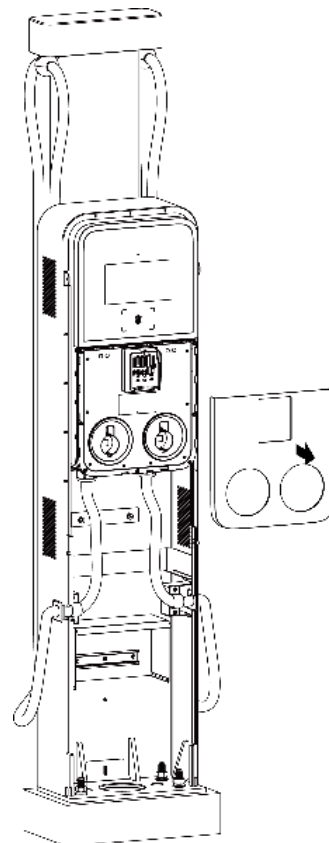
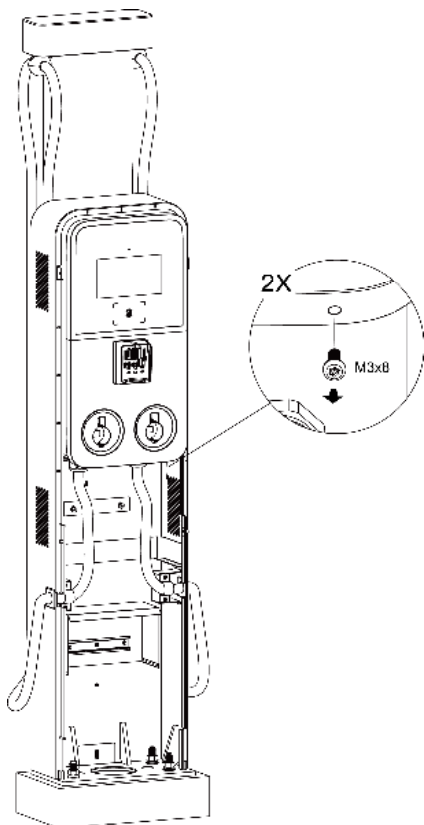

3. Unscrew the eight M3 x 8 screws using the screwdriver T10 and **set the screws aside.**
4. Flip the maintenance cover upward. Next, insert the two M6 x 25 screws into the two holes and tighten them to 4–5 ft/lbs (5–7 Nm) to secure the charging station using the socket wrench.

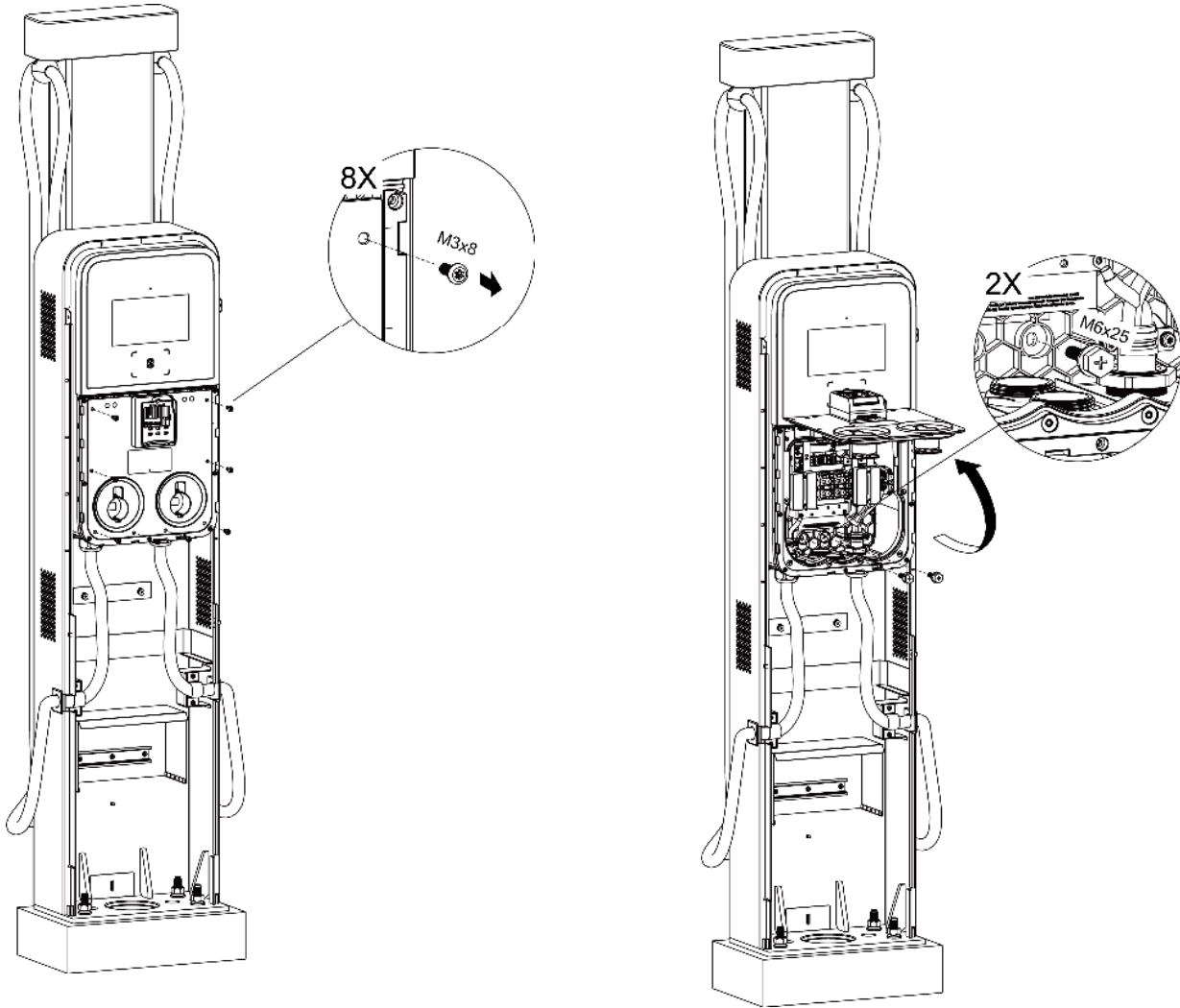

After the above installation steps are finished, you are ready to start AC input wiring. Please refer to **Section 4.5** to proceed.

4.4.8 Completing the Installation

1. Ensure all the installation and wiring are secured and correct. Flip the maintenance cover downward. Reinsert the eight M3 x 8 screws and tighten them.
2. Reinstall the faceplate by reinserting the two M3 x 8 screws and tighten them.

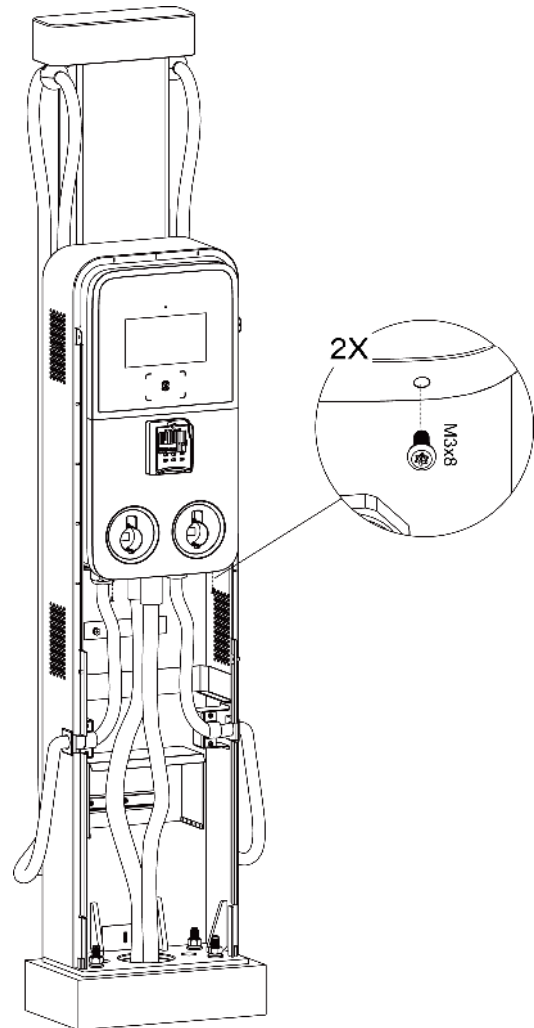
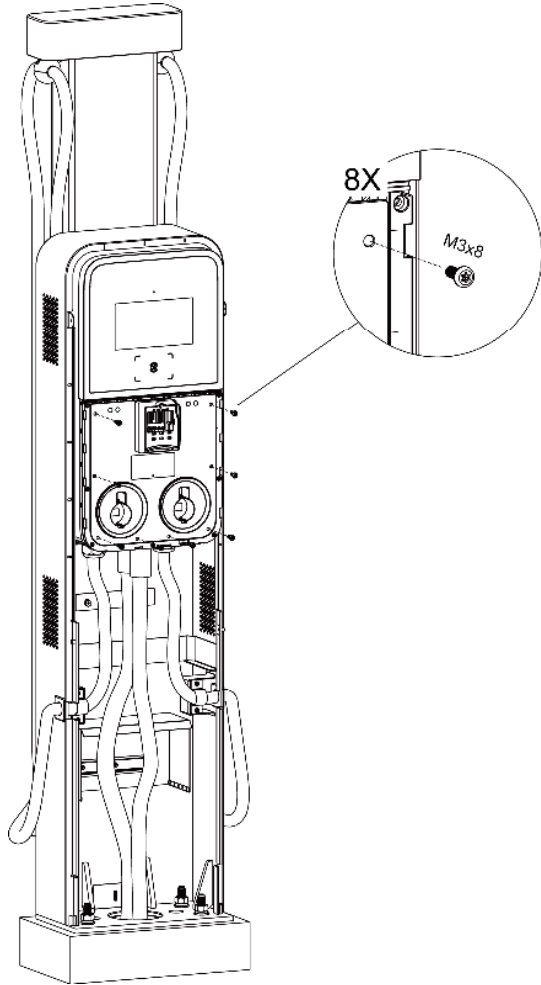

3. Reinstall the lower front cover of the pedestal by screwing and tightening the two M5 x 20 security screws.

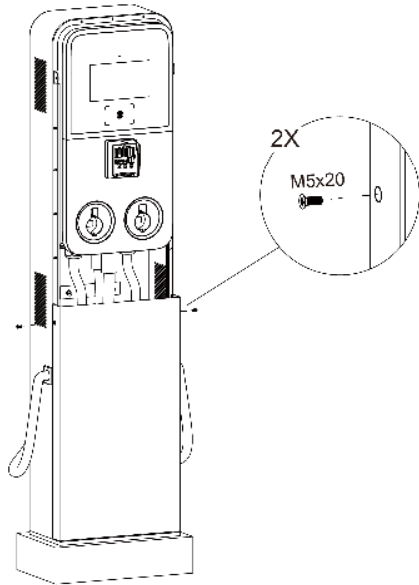

4. Reinstall the upper front cover of the pedestal and secure it with the two M5 x 20 security screws and tighten the screws.

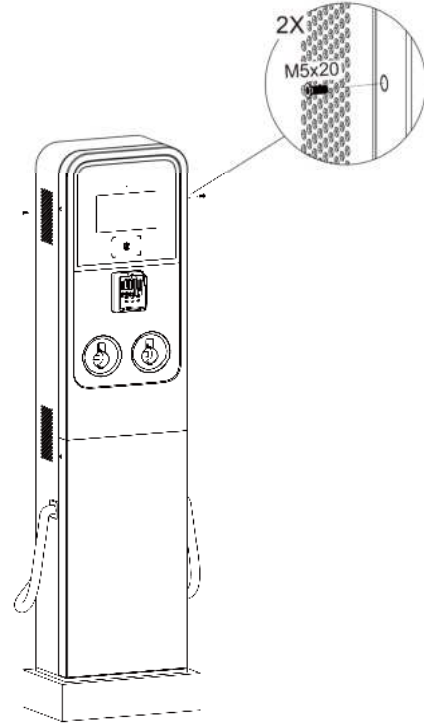

5. Plug the charging connectors into the holsters.

6. Use the hole plugs (B) and frame hole covers (A) to bung the holes. **Cable Management System Model B only.**

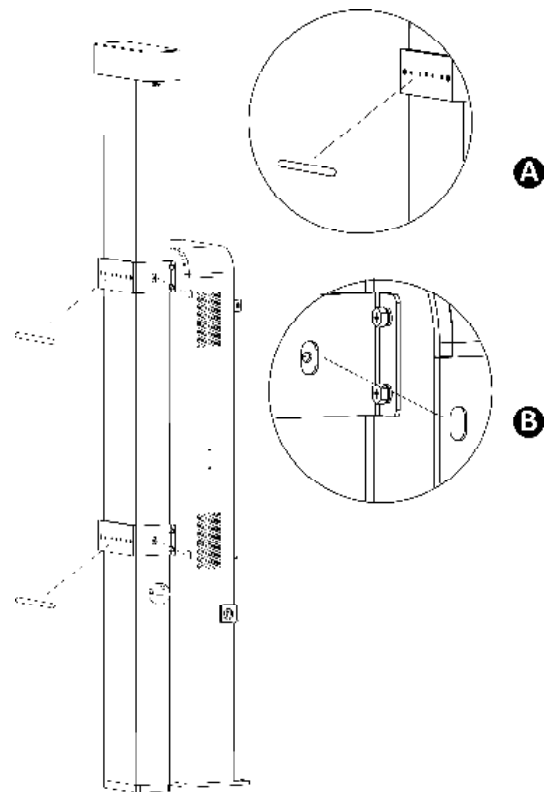

4.5 AC Input Wiring

4.5.1 Cable Specifications

	Wire Size	Cable Lug
L1	4 AWG	EVN25-16
L2/N	4 AWG	EVN25-16
PE	4 AWG	RNB8-6S

4.5.2 Installing Conduit

NOTE

This section is applicable for **Charging Station (Wall Mount)** and **Charging Station + CMS_Model B**.

Before connecting the AC input cable, remove the 1.69-inch (43 mm) conduit knockout (A) and install the appropriate conduit depending on single input or dual inputs.

NOTE

The single-port MaxiCharger supports single input only. Remove one conduit knockout and install the conduit.

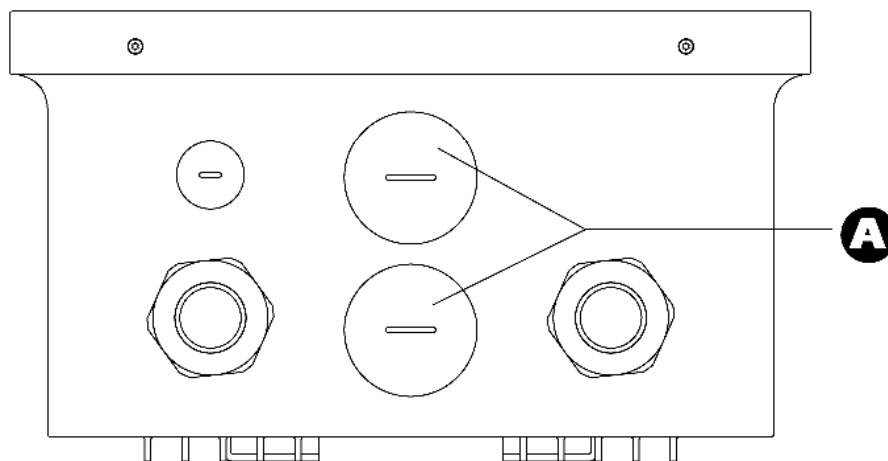

4.5.3 Connecting the Wires

1. Strip the wires to 0.63" (16 mm).
2. Use a crimping tool to attach cable lugs (not provided) to the exposed core wires.
3. Insert the AC input cable into the inlet hole.
4. Loosen the screws on the L1 and L2/N terminal ports.
5. Connect the L1 and L2/N wire to the terminal ports as per the diagram and secure them by tightening the screws to 3 ft/lbs (4 Nm).
6. Use the M5 x 10 screw (s) to attach the PE wire (s) to the terminal port (s) as per the diagram. Tighten the screw (s) to 3 ft/lbs (4 Nm) using the T25 screwdriver.

IMPORTANT

- Make sure the port 1 and 3, the port 2 and 4 are used as a group.
- If you install a circuit breaker or residual current circuit breaker on the pedestal, the pedestal must be grounded properly.

Single-port MaxiCharger

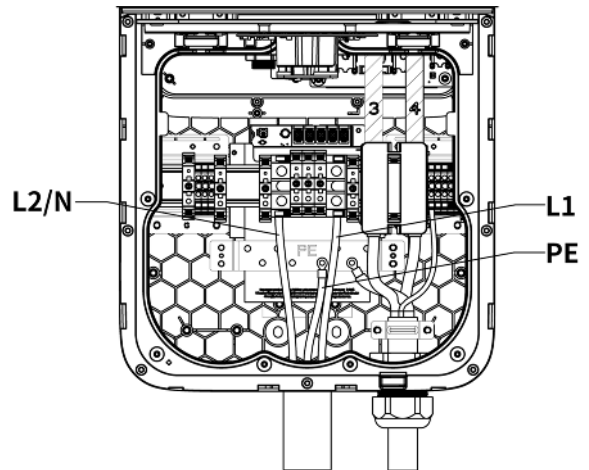

Dual-port MaxiCharger

Dual Inputs

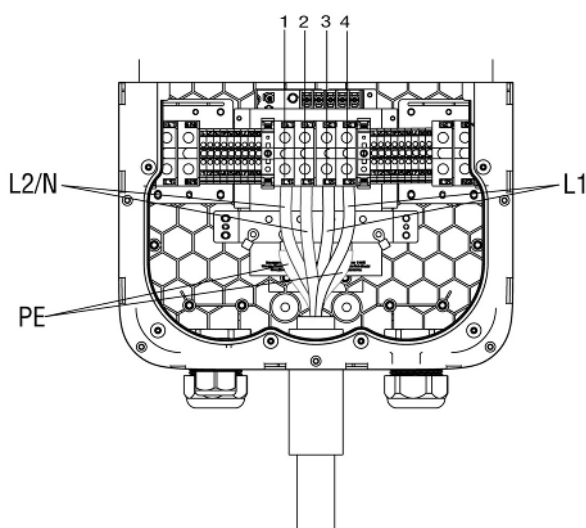

Single Input

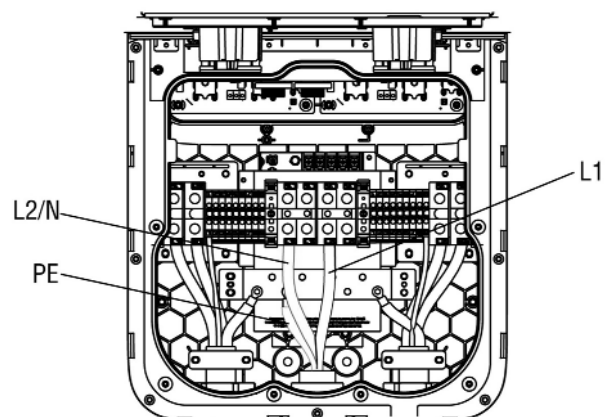

Install the Power Sharing Kit (For the Dual-port MaxiCharger Only)

For single input application to the dual-port MaxiCharger, before connecting L1, L2/N, and PE wires, install the power sharing kit: put the four spacers (C) into the four holes respectively and cover them with the two double tee nuts (B). Insert the four M4 x 26 screws (A) and tighten the screws.

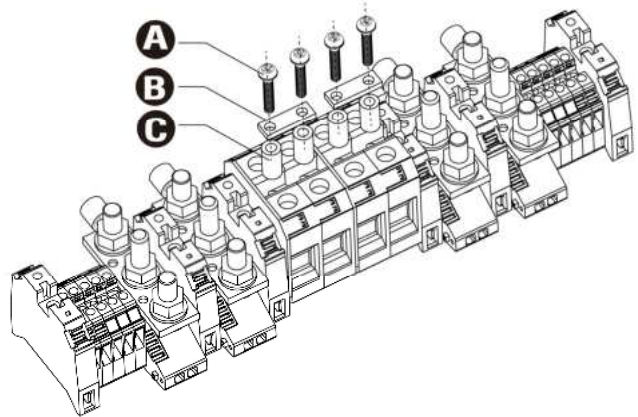

4.5.4 Adjusting the Rated Current

The MaxiCharger AC Ultra allows you to manually adjust the current output using the current selector.

1. Open the maintenance cover to locate the current selector.
2. Use a flathead screwdriver to set the rotary switch to an appropriate position as per the table below.

NOTE
The single-port MaxiCharger has the right current selector only.

Position	Amperage (A)
0	Not in Use
1	16
2	24
3	32
4	40
5	48
6	50
7	64
8	72
9	80

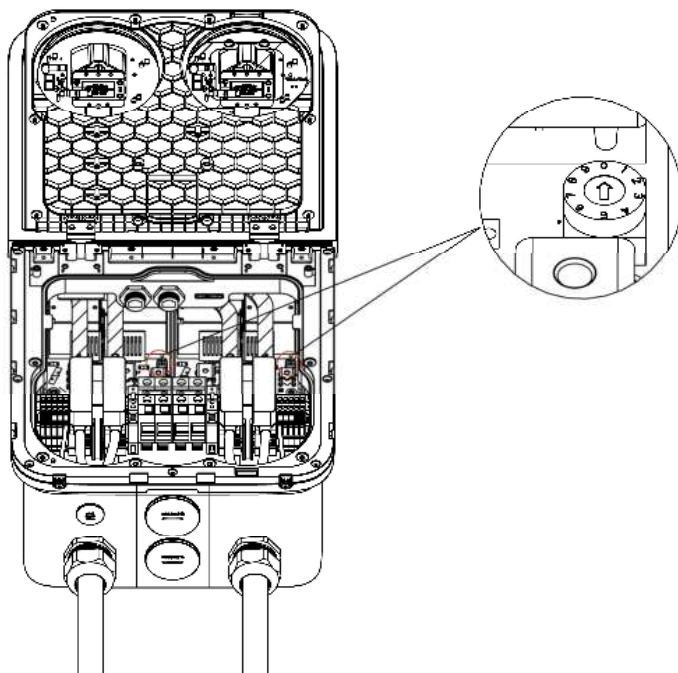

4.6 Connecting to the Internet

The MaxiCharger AC Ultra can access the Internet via Ethernet Cable, Wi-Fi or cellular network. The installation process vary between Ethernet cable and cellular network connections. No mechanical or electrical installation is needed for Wi-Fi connection. Select the optimal method to connect the Internet and follow the steps below accordingly.

4.6.1 Via the Ethernet cable

1. Insert the Ethernet cable with the RJ45 plug through the bottom Ethernet cable port (A).
2. Plug the Ethernet cable into the RJ45 port (B) as shown.

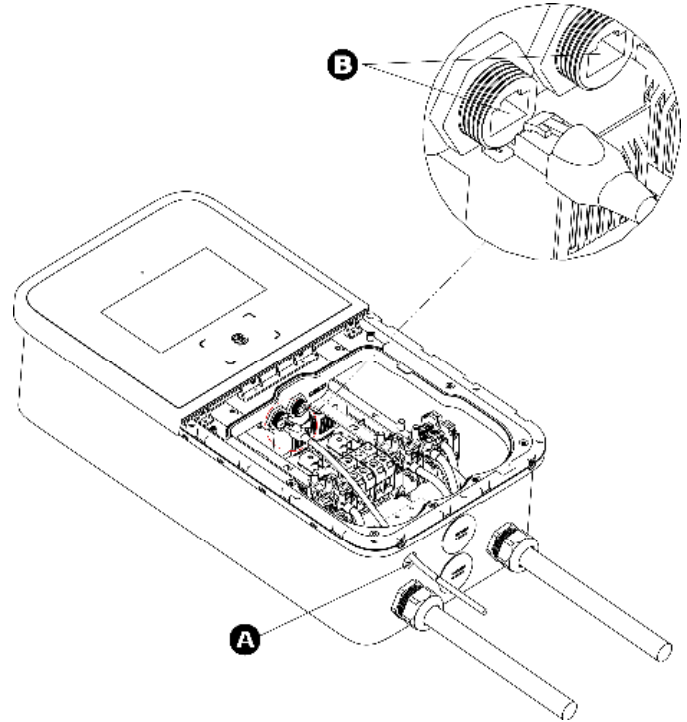

In the case of more chargers, network can be accessed with only the first charger connecting an Ethernet cable to a router.

NOTE

- Select any one of two RJ45 ports (B) to connect.
- The “first charger” means the MaxiCharger that is closest to the router.

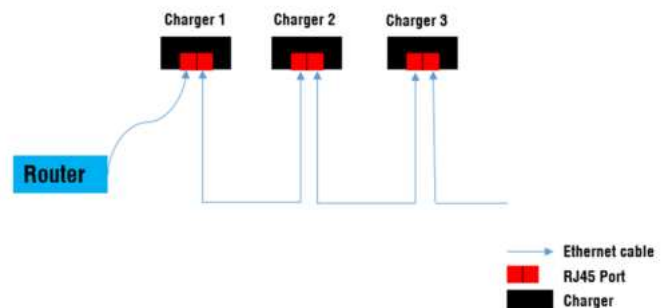

4.6.2 Via Cellular Network

NOTE

Ensure the cellular signal in the installation site is strong enough.

1. Eject the SIM card tray (B) using the eject button (A) on the right.
2. Place the SIM card into the card tray and ensure it is inserted correctly.
3. Push the card tray back in place.

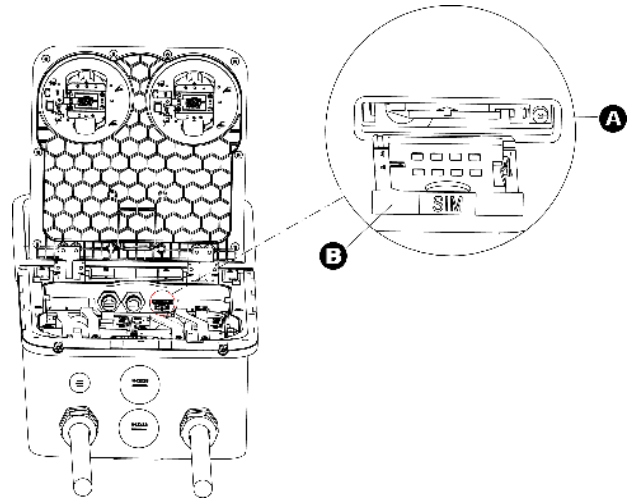

4.7 Energizing the MaxiCharger

IMPORTANT

- Ensure that the MaxiCharger is installed according to the instructions in this manual.
 - Make an emergency plan that instructs people what to do in case of an emergency.
 - Provide charging instructions to the user.
 - The manufacturer or a trained technician should perform the commissioning work. Contact the manufacturer when the MaxiCharger is ready for commissioning.
 - The space around the MaxiCharger shall not be blocked by snow or other objects.
 - Ensure that the maintenance work has carried out on the MaxiCharger.
1. Make sure that the upstream breaker stays in the **OFF** position and locked during the procedure.
 2. Tighten the screws and bolts of key parts and make sure the MaxiCharger is clean inside to prevent the electronic components from being damaged by dust or particles.
 3. Use the multimeter to check the circuit connections among L1, L2/N, and PE. If short circuit occurs, contact Autel technical support.
 4. Reconfirm that the power sharing kit is not used for dual inputs wiring connection. For single input wiring connection for the dual-port MaxiCharger, ensure the power sharing kit is installed properly.
 5. Confirm that the current selector works well with grid capacity and AC input cable.
 6. Reconfirm that the input voltage is within the range of 161 – 276 VAC. If it exceeds the range, connect the correct power; if it is correct, proceed with next step.
 7. Contact Autel technical support to turn on the upstream breaker and check the screen display.
 - If the screen display doesn't work properly, please contact Autel technical support.
 - If the screen works soundly, move to next step.
 8. Close the covers. You are ready to set the MaxiCharger.

5 Local Service Portal Operations

5.1 Setting the OCPP Parameters

NOTE

The settings should be performed by an installation engineer.

After startup, set the settings on screen.

1. Select the language.

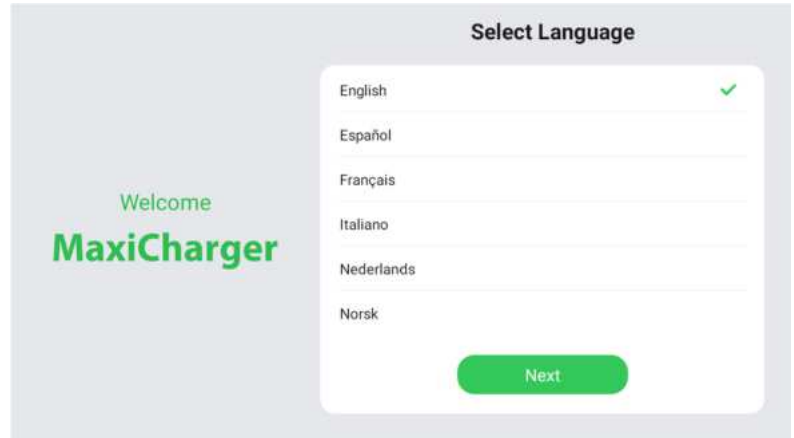

2. Select the network.

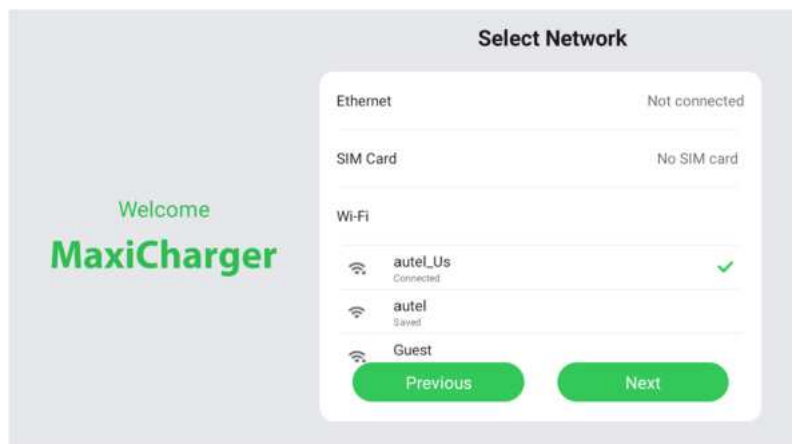

3. Select the time zone

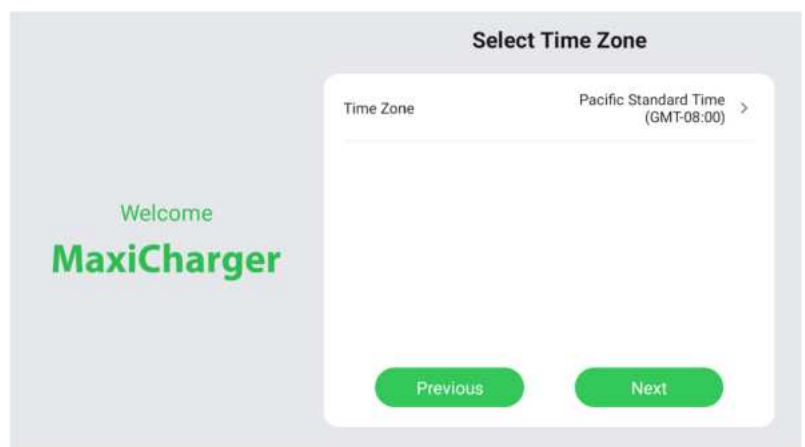

4. Select the input cable.

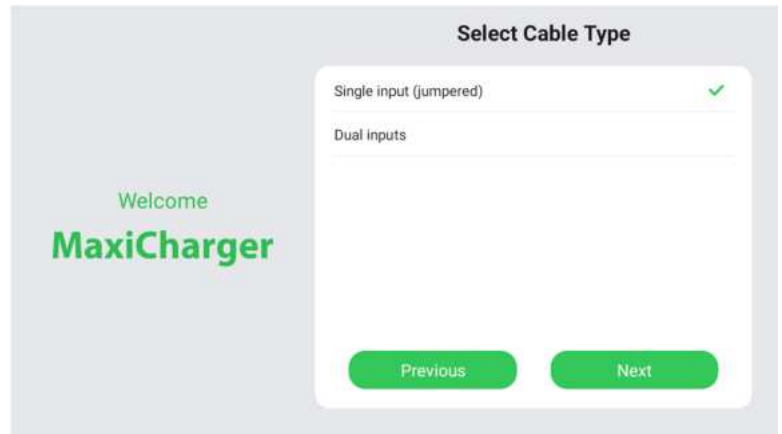

5. Set the input cable current.

NOTE

- For the dual-port MaxiCharger, “Cable 1” means the cable that supplies the power to the left port facing the charger.
- “Cable 2” input current will be required to be set for dual inputs.

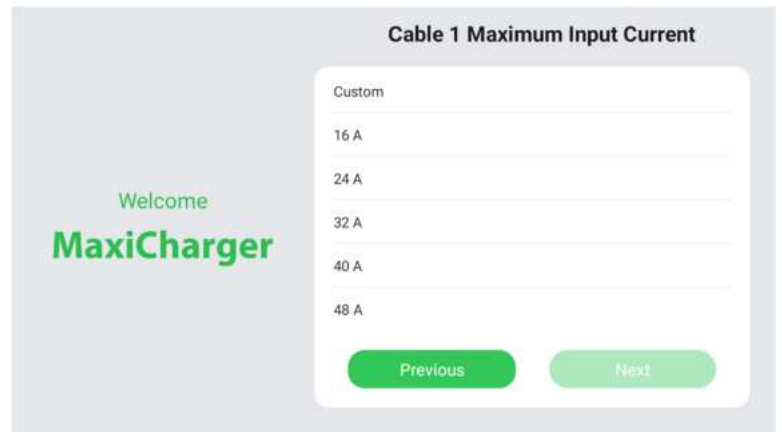

6. Tap **Complete** to finish the settings and enter the home page.

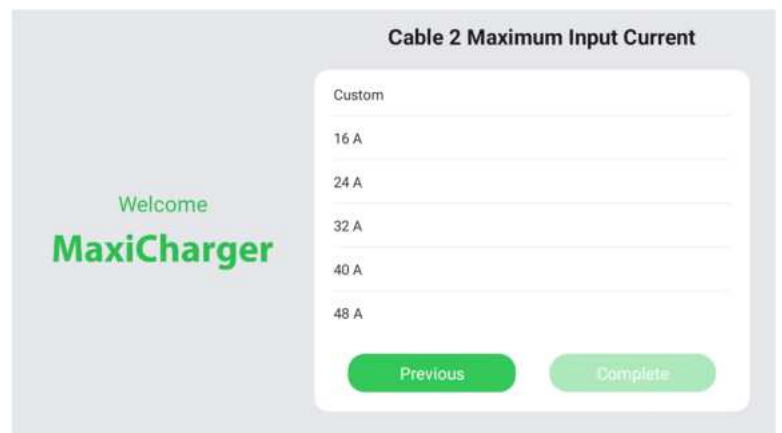

Detailed device settings can be set in **Device Maintenance**. Follow the instructions below to set the OCPP parameters.

1. Tap on the icon \$ to open the Cost Details page.

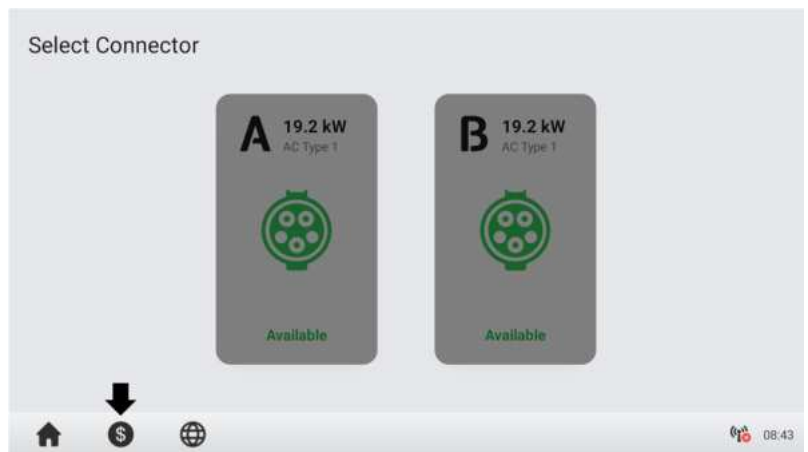

2. Double-click the upper-left corner of the screen.



3. Tap **Device Maintenance**. Enter the password to continue. **The password is the last 6 digits of the S/N number shown in the product label.**

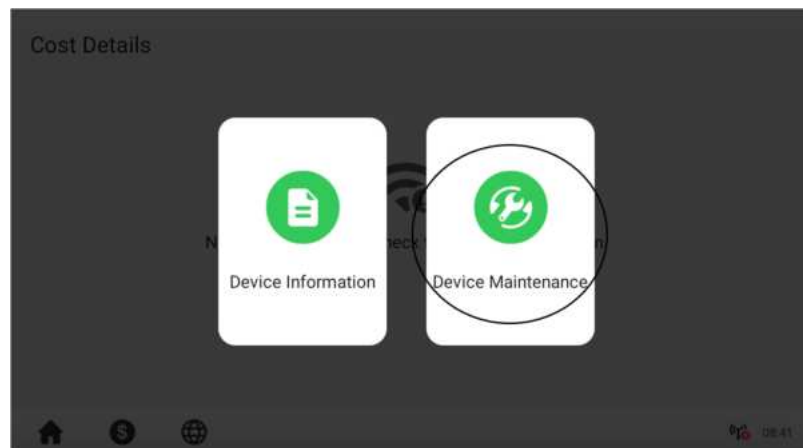

- Then the device maintenance screen will appear. Tap **Set Parameters** to set the OCPP parameters.

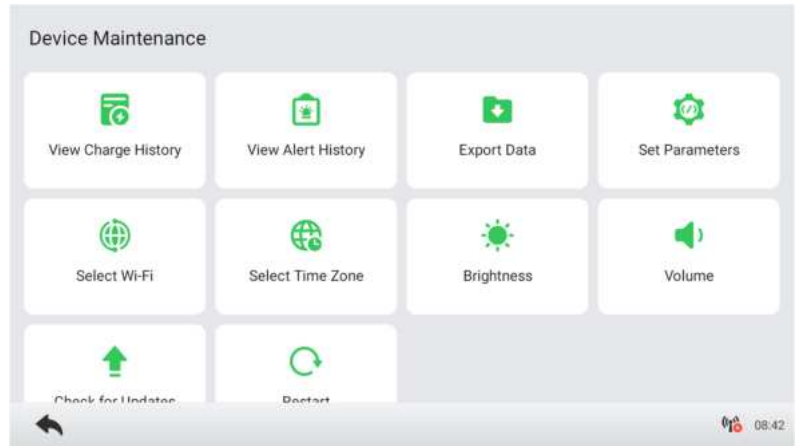

- Set the following parameters according to the actual conditions. Tap the parameter in the **Parameter Value** column to change the setting.

Set Parameters

Parameter Name	Parameter Value	Parameter Description
Payment method	Scan code/Swipe card via RFID/Swipe credit card	/
Backend switch	Available	/
Regional server	US	/
Running environment	Production environment	/
OCPP IP	gateway-eneprodus.autel.com	OCPP master address
OCPP-URL address	/ws/webSocket?sn=	OCPP-URL address
Port number	443	OCPP port number

Set Parameters

Parameter Name	Parameter Value	Parameter Description
Port number	443	OCPP port number
OCPP encryption method	wss	/
Country code	US	Country abbreviation code
Backend IP	gateway-eneprodus.autel.com	Backend IP
Stop button	Show	/
AC input wiring	Single input (jumped)	/
Cable input current	64.0A	Maximum input current

- “Output power sharing” is required to set only for the dual-port MaxiCharger with single input.

Set Parameters

Parameter Name	Parameter Value	Parameter Description
AC input wiring	Single input (jumped)	/
Cable input current	64.0A	Maximum input current
Output power sharing	On	/
Connector 1 output current	12.0A	Maximum output current of single connector
Connector 2 output current	22.0A	Maximum output current of single connector
One-button start	On	/

5.2 Configuring the Cloud Platform

The Autel Charge Cloud, a one-stop charging management solution, is intended to address the needs of many use-cases including commercial, residential, governmental, car dealers, and fleets. Contact Autel technical support for subscription and learn more details on Autel Charge Cloud manual.

If a third-party cloud platform is used, contact the third-party personnel for configuration.

6 Maintenance

WARNING

- Disconnect the power supply to the MaxiCharger during the entire maintenance procedure.
- Make sure that unauthorized personnel are kept at a safe distance during maintenance.
- Wear proper personal protective equipment, such as protective clothing, safety gloves, safety shoes, and safety glasses.
- If you remove the safety devices for maintenance, reinstall them after completing the work.

6.1 Inspection and Maintenance

6.1.1 Routine Maintenance

Route maintenance can keep the MaxiCharger in safe and stable state. Regularly conduct a visual inspection of the following points:

- Cable and connector: Check for cracks or ruptures;
- Display: Check for damage and cracks. Check whether the touchscreen works or any error message prompts.
- MaxiCharger coating: Check for damage, cracks or ruptures;
- MaxiCharger: Check for rust or damage. Check if the equipment surface temperature is too high.

➤ To remove rust

1. Stop any charging processes and power off the MaxiCharger.
2. Remove rough dirt by spraying with low-pressure tap water.
3. Apply a neutral or weak alkaline cleaning solution and let it soak.
4. Remove dirt by hand with a damp and non-woven nylon cleaning pad.
5. Rinse thoroughly with tap water.
6. Apply wax or a rust-preventive primer for extra protection if needed.

WARNING

- Before cleaning, stop any charging processes and do not connect the power to the MaxiCharger. Failure to do so may cause damage and/or personal injury or death.
- Do not apply high-pressure water jets and avoid water leaking into the MaxiCharger. Make sure that the inside of the MaxiCharger is dry during cleaning.
- Do not use caustic solvents, sprays, solvents or abrasives. Use cleaning agents with a pH 6 at the maximum for strong stains only.

6.1.2 Special Inspections

The following special inspections are needed for safe use:

- Check if the MaxiCharger was stuck by lightning.
- Check if the MaxiCharger was damaged due to an accident or fire.
- Check if the MaxiCharger installation site has been flooded.



WARNING

Stop any charging processes and do not connect the power to the MaxiCharger until all the inspections are completed.

6.2 Remote Maintenance

The MaxiCharger has the function of connecting to the cloud platform to monitor parameters in real time. This provides remote upgrades, remote diagnosis, and remote service functions, and can timely identify and locate problems in the operation process.

- System self-check for abnormality daily.
- If any abnormal operation is found, contact your local dealer or Autel technical support promptly.
- Autel service engineers can check logs, update configurations and programs, and provide remote maintenance services, such as remote management, diagnosis, configuration, and upgrades.

6.3 Maintenance Schedule

Item	Frequency	Actions
Connector	Every 3 months	Check for cracks or ruptures on the connector.
Input Cable	Every 3 months	Check for cracks or ruptures on the cable.
MaxiCharger	Every 3 months	Clean and check for damage.

7 Troubleshooting

Item	Problems	Solutions
1	The charging session does not start as scheduled.	Do not insert the connector into your EV charging port before setting up a charging schedule for the first time. Insert the EV charging cable after the schedule is set up.
2	Over-voltage	Use the multimeter to check whether the voltage on the power input is too high. If the result is greater than or equal to 115 % of the rated voltage (263 V), contact local power grid company.
3	Under-voltage	Use the multimeter to check whether the voltage on the power input is not sufficient. If the result is less than or equal to 70 % of the rated voltage (161 V), contact local power grid company.
4	Ground fault	Make sure the charger is grounded correctly.
5	Power failure	Make sure the switch to the circuit breaker is on.
6	Over-heating	<ul style="list-style-type: none"> ● Check whether the EV charging cable is securely connected. ● Ensure the operating temperature is within the specified range on the label. ● Stop charging. Restart charging until it is within the operation temperature range.
7	Residual current detected	Unplug the vehicle and plug in again. If the problem persists, contact customer support.
8	Internet connection fails	<ul style="list-style-type: none"> ● Try to connect another device to the same Internet, verifying the Internet connection is working properly. ● If the problem persists, contact customer support.

8 Specifications

8.1 General Specifications

Item	Description	
	Single Port	Dual Ports
AC Power Output Rating	19.2 kW	19.2 kW x 2
AC Power Input Rating	208/240 V AC 60 Hz single phase @ 16 A, 24 A, 32 A, 40 A, 48 A, 50 A, 64 A, 72 A, 80 A	
Circuit Breaker Options (A)	20 A, 30 A, 40 A, 50 A, 60 A, 70 A, 80 A, 90 A, 100 A (must be sized at 125% of the maximum load, e.g., 100 A breaker for 80 A output)	
Input Wiring Scheme	L1, L2, and PE (no neutral)	
Input Type	Hardwired	
Connector Type	SAE J1772	
Charging Cable Length	<ul style="list-style-type: none"> ● 25.16 ft. (7.67 m) ● 24.61 ft. (7.5 m) ● 20.24 ft. (6.17 m) ● 16.4 ft. (5 m) 	<ul style="list-style-type: none"> ● 25.16 ft. (7.67 m) x 2 ● 24.61 ft. (7.5 m) x 2 ● 20.24 ft. (6.17 m) x 2 ● 16.4 ft. (5 m) x 2
Display	8 inches, 1280*720 touchscreen	
Metering	CTEP Certified	
Ground Fault Detection	20 mA CCID with auto retry	

Item	Description	
	Single Port	Dual Ports
Protection	<ul style="list-style-type: none"> ● Overcurrent ● Overvoltage ● Undervoltage ● Integrated surge protection 	
Connectivity	<ul style="list-style-type: none"> ● 4G ● Wi-Fi ● Ethernet ● RS485 	
Card Reader	<ul style="list-style-type: none"> ● ISO 15693 ● ISO 14443 ● NFC ● Credit Card (Optional) 	
Communication Protocols	<ul style="list-style-type: none"> ● OCPP 1.6J ● Upgradable to OCPP 2.0.1 	
Mounting	<ul style="list-style-type: none"> ● Wall Mount ● Floor Mount 	
Enclosure Ratings	NEMA 4, indoor or outdoor installation	
Operating Temperature	-40 to 131 °F (-40 to 55 °C)	
Storage Temperature	-40 to 158 °F (-40 to 70 °C)	
Operating Humidity	< 95 %, Non-Condensing	

Item	Description	
	Single Port	Dual Ports
Operating Altitude	6561.7 ft. (2000 m)	
Dimension (H x W x D)	<ul style="list-style-type: none"> ● Charging Station: 25" x 13" x 7" (625 mm x 320 mm x 170 mm) ● Pedestal: 57" x 14" x 8" (1440 mm x 360 mm x 197 mm) ● Cable Management System: 107" x 13" x 4" (2720 mm x 320 mm x 110 mm) 78" x 13" x 4" (1970 mm x 320 mm x 110 mm) 	
Safety and Compliance	<ul style="list-style-type: none"> ● UL 2594 ● UL 2231-1 ● UL 2231-2 ● UL 1998 ● CSA C22.2. NO.280 	
Codes and Standards	<ul style="list-style-type: none"> ● FCC Part 15 Class B ● ENERGY STAR ● Open ADR 2.0b ● NEC Article 625 	
Warranty	3 years	
Models	AU19	AU38

8.2 Product Dimensions

Charging Station

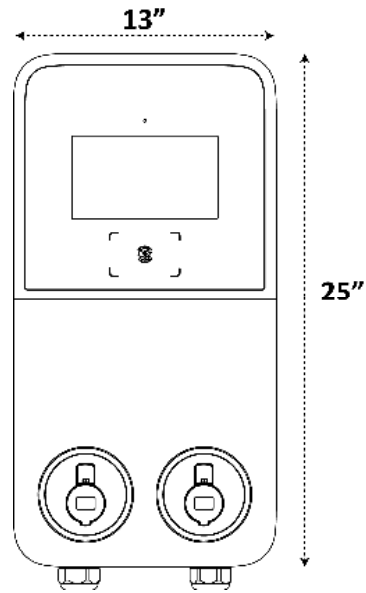

Front View

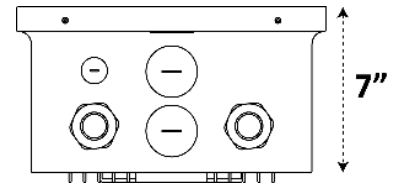

Bottom View

Pedestal

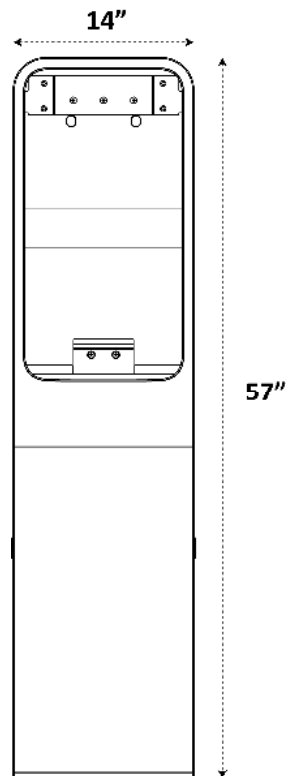

Front View

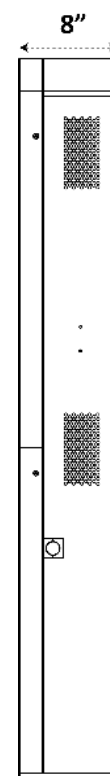

Side View

Cable Management System

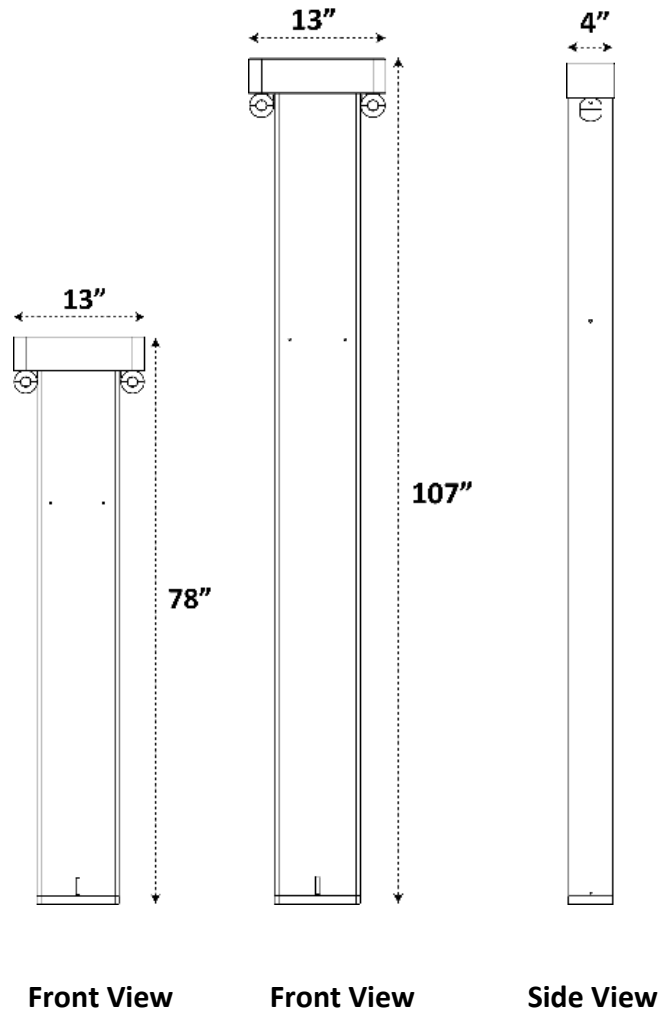

9 Compliance

FCC regulatory conformance:

This device complies with Part 15 of the FCC Rules. Operation is subject to the following two conditions:

- (1) This device may not cause harmful interference.
- (2) This device must accept any interference received, including interference that may cause undesired operation.

NOTE: This equipment has been tested and found to comply with the limits for a Class B digital device, pursuant to part 15 of the FCC Rules. These limits are designed to provide reasonable protection against harmful interference in a residential installation.

This equipment generates uses and can radiate radio frequency energy and, if not installed and used in accordance with the instructions, may cause harmful interference to radio communications. However, there is no guarantee that interference will not occur in a particular installation. If this equipment does cause harmful interference to radio or television reception, which can be determined by turning the equipment off and on, the user is encouraged to try to correct the interference by one or more of the following measures:

- Reorient or relocate the receiving antenna.
- Increase the separation between the equipment and receiver.
- Connect the equipment into an outlet on a circuit different from that to which the receiver is connected.
- Consult the dealer or an experienced radio/TV technician for help

NOTE: The manufacturer is not responsible for any radio or TV interference caused by unauthorized modifications to this equipment. Such modifications could void the user's authority to operate the equipment.

RF Exposure

This equipment complies with FCC radiation exposure limits set forth for an uncontrolled environment. This equipment should be installed and operated with minimum distance of 20 cm between the radiator and your body. This transmitter must not be co-located or operating in conjunction with any other antenna or transmitter.

IC regulatory conformance:

This device complies with CAN ICES-3 (B)/NMB-3(B).

This device contains licence-exempt transmitter(s)/receiver(s) that comply with Innovation, Science and

Economic Development Canada's licence-exempt RSS(s). Operation is subject to the following two conditions:

(1) This device may not cause interference.

(2) This device must accept any interference, including interference that may cause undesired operation of the device.

Cet appareil est conforme à la norme CAN ICES-3 (B)/NMB-3 (B).

Cet appareil contient des émetteurs / récepteurs exempt (s) de licence qui sont conformes aux RSS exemptes de licence d'Innovation, Sciences et Développement économique Canada. Son fonctionnement est soumis aux deux conditions suivantes:

(1) Cet appareil ne doit pas provoquer d'interférences.

(2) Cet appareil doit accepter toute interférence, y compris les interférences susceptibles de provoquer un fonctionnement indésirable de l'appareil.

RF Exposure

This equipment complies with IC radiation exposure limits set forth for an uncontrolled environment. This equipment should be installed and operated with minimum distance of 20 cm between the radiator and your body. This transmitter must not be co-located or operating in conjunction with any other antenna or transmitter.

Cet équipement est conforme aux limites d' exposition aux rayonnements de la IC établies pour un environnement non contrôlé. Cet équipement doit être installé et fonctionner à au moins 20 cm de distance d'un radiateur ou de votre corps.

10 Appendix

10.1 Fault Code List

The table below contains the fault codes on the Autel Charge Cloud and their descriptions on the charger's display.

Fault Codes	Descriptions
01	Mains overvoltage
02	Mains undervoltage
04	Mains over-frequency
08	Mains under-frequency
10	Phase loss
20	Line/Neutral reverse connection
40	Ground fault
80	Abnormal shutdown
100	Over-temperature
200	Leakage current
400	CP voltage abnormal/grounded
800	Contactors abnormal
1000	Output overcurrent
2000	Vehicle S2 failure
4000	Vehicle CP negative failure
8000	PP signal disconnected
10000	PP signal abnormal
20000	Electronic lock fault
40000	PME fault
80000	PME failed to disconnect relay
100000	COMM error with control board
200000	Electric meter abnormal
400000	Data error
800000	Leakage current (AC)
1000000	Trip fault
2000000	Sensor self-test fault
4000000	Output ground fault
8000000	Ground self-test fault
10000000	Microelectronics fault

Fault Codes	Descriptions
20000000	Temperature sensor abnormal
40000000	Power System abnormal

AUTEL[®]
www.autelenergy.com